

# SINCLAIR

USER

JANUARY 1987 No 58 £1

IT'S  
A CRIME  
NOT TO  
READ  
SU

## Fancy a DREDDFUL New Year?



**FESTIVE QUIZ!**  
**ALIENS**  
COLOUR MAPS!  
VOTE IN THE  
1986 **SU** AWARDS  
THE PAWN  
REAL FLIGHT  
SIMULATOR  
TOP GUN COMPO  
**DOUBLE TAKE**  
EASY GUIDE TO  
SPECTRUM FAULT  
FINDING SOLVED

CHEETAH'S NEW  
MIDI MK5



PRO MUSIC FOR  
UNDER £100?



sinclair

MONSTER MEM

# GET YOUR HANDS ON THE NEW SINCLAIR 128K +2. BEFORE EVERYBODY ELSE DOES.



The new 128K ZX Spectrum +2 is more than just a monster memory. It's the ultimate family computer. With a built-in datacorder for easier loading, superb graphics capability, two joystick ports, a proper typewriter keyboard and more games available than you can shake a joystick at (well over 1000 software titles, in fact). Better get your hands on the new 128K ZX Spectrum +2 soon. Before they do.

# £149

## BUY WITH CONFIDENCE. MONSTER VALUE

Available from: Alders, Boots, Clydesdale, Comet, Connect, Co-op, Currys, Dixons, Electric Supreme, Laskys, John Lewis, John Menzies, Power City, Rumbelows, Ultimate, WH Smith, Wigfalls, and good independent stores.

We recommend Sinclair Quality Control Software.

To: Sinclair, P.O. Box 462, Brentwood, Essex C14 4EF.  
Please send me more information about the Sinclair 128K ZX Spectrum + 2.

Name

Address

# sinclair

**Editor**  
David Kelly  
**Deputy editor**  
John Gilbert  
**Senior staff writer**  
Graham Taylor  
**Staff writer**  
Jim Douglas  
**Designer**  
Gareth Jones

**Adventure help**  
Gordo Greatbelly

**Zapchat**  
Jon Riglar

**Helpline**  
Andrew Hewson

**Contributors**  
Richard Price  
Andy Moss  
Gary Rook

**Hardware Correspondent**  
Rupert Goodwins

**Advertisement manager**  
Louise Fanthorpe  
**Deputy Advertisement Manager**  
Jacqui Pope

**Production assistant**  
Alison Morton

**Advertisement secretary**  
Linda Everest

**Subscriptions manager**  
Carl Dunne

**Publisher**  
Terry Pratt

**Telephone**  
01-251-6222

Sinclair User is published monthly by  
EMAP Business & Computer  
Publications

**Cover Illustration**  
Courtesy of 2000AD magazine

If you would like to contribute to Sinclair  
User please send programs or articles to:

Sinclair User  
EMAP Business & Computer  
Publications  
Priory Court  
30-32 Farringdon Lane  
London EC1R 3AU

Original programs should be on cassette  
and articles should be typed. Please write  
Program Printout on the envelopes of all  
cassettes submitted. We cannot undertake  
to return cassettes unless an SAE is  
enclosed. We pay £20 for each program  
printed and £50 for star programs.

Typeset by PRS Ltd, 27 New St,  
St. Neots, Cambs.

Printed by Nene River Press,  
Woodston, Peterborough.

Distributed by EMAP Publications Ltd.

© Copyright 1986 Sinclair User  
ISSN No 0262-5458

ABC 90,215 July-Dec 1985

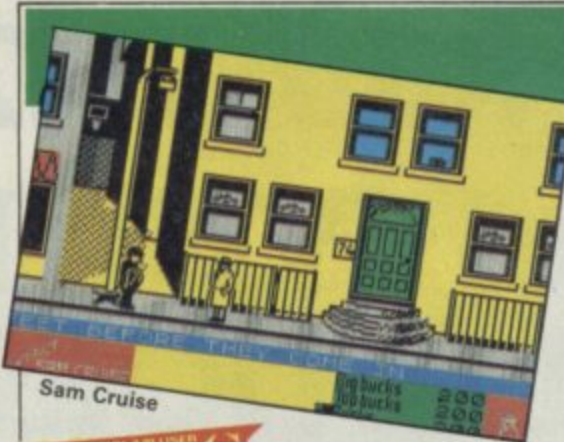

Sam Cruise

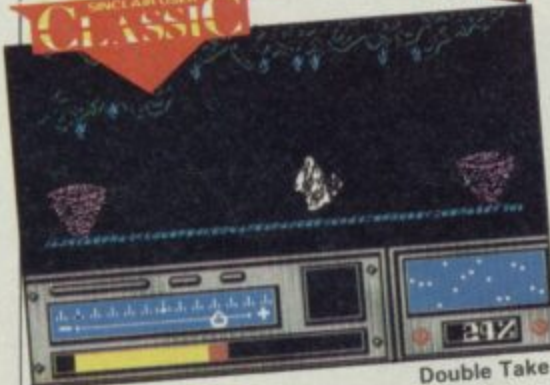

Double Take



Shares



Aliens

## SOFTWARE

### ARCADE

SHAO-LIN'S ROAD  
ALIENS  
DEFCON  
BREAK THRU  
COBRA  
DOUBLE TAKE  
DONKEY KONG  
CONTACT SAM CRUISE  
HIGHLANDER  
FROSTBITE  
FAT WORM BLOWS A SPARKY  
NOSFERATU  
CITY SLICKER  
DR WHAT  
ROGUE TROOPER

### STRATEGY/SIMULATION

THEY STOLE A MILLION  
SAMURAI

### WORK OUT

VALTRAK 4  
INVESTMENT MONITOR  
SHARES

### BUDGET

ZUB  
OBLIVION  
BLACH HAWK  
ALIEN  
PHANTOMAS  
KINGS KEEP  
TERRA COGNITA  
HERCULES

### ADVENTURE

DRACULA  
THE ARCHERS  
THE PAWN  
PARADISE CONNECTION  
DOME TROOPER  
PREHISTORIC ADVENTURE  
DEMON FROM THE DARKSIDE  
QUEST FOR THE GOLDEN ORANGE PEEL  
ADVENTURE  
DON'T PANIC, PANIC NOW

### QL

GRAPHICS TOOLKIT  
BETTER BASIC  
QLIBERATION

## HARDWARE

### Pistols at dawn 18

Mastertronic's Magnum and Brittan-  
nia's Phasor 1 joysticks shoot it out  
face to face

### Cheetah's MK5 22

Is this professional music on a  
budget?

### RamPrint 111

Ram's printer interface has hidden  
depths

## DIAGNOSTICS

### Fault Finder 28

Hardware on the blink? Follow our  
easy-to-follow guide to find out what's  
up with your Spectrum

## THE YEAR 1986

### 1986 SU Readers Poll 68

Your chance to vote for your picks of  
the year - and to enter our real mega-  
compo

### The hack's eye view 71

Find out what we thought of the year!



## PREVIEWS

The programs of tomorrow, today! What's HAPPENING in the wonderful world of software. With Scalextric, Jail Break, Tempest, SAS Strikeforce, Kayleth, Super Soccer, Deep Strike, Legend of Kage . . .



Nemesis

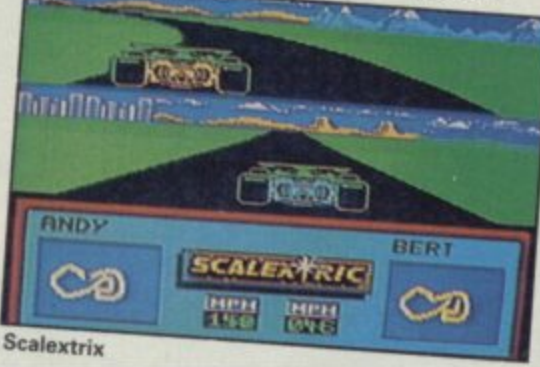

Scalextric

## COVER SMASH

Judge Dredd 108



THE EDGE	23
ELECTRIC DREAMS	24
QUICKSILVA	25
US GOLD	31
OCEAN	31
OCEAN	32
OCEAN	33
MICROSPHERE	33
OCEAN	52
MIKRO-GEN	52
DURRELL	59
PIRANHA	89
HEWSON	106
CRL	106
PIRANHA	109

AROILASOFT	59
CRL	63

MORELY DAVIS	116
MICHAEL SLATFORD	117
COTTAGE COMPUTING	117

MASTERTRONIC	39
ALPHA OMEGA	39
CREATIVE SPARKS	50
BUG-BYTE	50
CODE MASTERS	50
FIREBIRD	51
CODEMASTERS	51
ALPHA OMEGA	51

CRL	27
MOSAIC	86
RAINBIRD	100
BIRDSEED	101
MATAND	101
CRUSADER	101
COMPASS	103
DUAL DIMENSION	103
ADVENTURE	103
DENTED DESIGNS	103

PYRAMIDE	74
DIGITAL PRECISION	74
LIBERATION	74

## FEATURES

**Independent Adventures** 101

Some of the best Quilled amateur efforts revealed

**2000 AD heroes** 108

Judge Dredd – the law in Megacity One – and Rogue Trooper have both been tempted away from their cult comic and on to the little screen



**More Rubot buggy** 112

How it works and a prog to type in

**Big Bang** 116

Did you go for British Gas, BT or TSB shares? If so your micro can help you unravel the intricacies of the stock market

## SURVEY

**Simulations** 54

We pick the all-time top six

## PRINTOUT

**Crisis at Christmas** 79

Ron and Nancy have a problem this Christmas with our festive machine-code text adventure

## SEASONAL STUFF



**Festive Quiz** 48  
Could you make it in the software world?

## COMPETITIONS

**Top Guns – go for it** 55

We've got copies of Ocean's new high-flyer plus copies of the film sound-track, posters, and a chance for one special winner to see a real flight simulator in operation

**Murder off Miami** 94

Who dun it? Delta 4 and CRL that's who. And we've got an exclusive chance to go on a special murder-mystery weekend. It's just like *Cluedo* comes to life

## NEW FEATURE

**MapChat** 44  
Maps of the hottest games – in incredible 3D colour

## REGULARS

News	7
Charts	12
Letters	15
Code Talk – Anita Sinclair	17
The Write Stuff	19
Competition winners	20
ZapChat	40
Hewson's Helpline	72
Gordo's adventure tips	91
Sinclair Surgery	105
Next month	118
Gremlin	128

# The answer to the Spectrum-users prayer the **DISCIPLE**



**AVAILABLE NOW!**  
the all purpose interface to take  
your Spectrum to the limit

#### DISK INTERFACE

- ★ Allows up to 1.6 Mb of storage on 2 drives
- ★ Loads a full 48K program in 3.5 seconds
- ★ Simple Basic Syntax
- ★ Compatible with any standard drive – single or double density, single/double sided, 40/80 track, 3", 3½", 5¼".

#### SNAPSHOT BUTTON

- ★ Saves any program instantly – at any point you wish and as often as you like.

#### PRINTER INTERFACE

- ★ Compatible with the whole range of Centronics Parallel printers.
- ★ Uses normal Sinclair commands – LLIST, LPRINT, COPY
- ★ Permits user defined and screen graphics.

#### DUAL JOYSTICK PORTS

- ★ Sinclair and Kempston compatible.

#### NETWORKING

- ★ Operating system allows Disciple to act as file server; shared access to printer and disc drive for up to 64 Spectrums
- ★ Interface 1 Compatible



Use the disciple with any Spectrum – even the new Plus Two model.

## the **DISCIPLE**

the ultimate disk, printer, joystick and network controller for the Spectrum **£73.70 (+VAT)**

Designed by Miles Gordon Technology for Rockfort Products (a trading division of Vignesh Ltd)

For more information call us  
on 01-203 0191 or visit our  
London showroom for a  
demonstration

To: Rockfort Products, 81 Church Road, London NW4 4DP  
Please send me POST FREE.....

(Quantity) DISCIPLE Interface

@ £84.75 each, including VAT & P&P.

I enclose CHEQUE/POSTAL ORDER for £.....

OR debit by ACCESS  or VISA  (tick as appropriate)

CARD NO

EXPIRY DATE .....

SIGNATURE .....

NAME (Block Capitals).....

ADDRESS.....

Postcode.....

Orders and trade enquiries welcome. Telex 946240. Ref. 190-12450

## UNDER RAPS!

# 128K+2 JOYSTICK ROW

● Paul Tuck has written a QL program which will be released by Realtime Software – the label responsible for the Spectrum version of Star Glider. It's called Defusion and is a multi-screen levels-and-ladders game with big, colourful sprites.

● Design Design is completing The Sewer for Domark. What can one say? It's an action arcade game and will follow Kat Trap on to the Streetwise label

● Don Priestly, author of Trap Door, Popeye and Minder has just begun work on a new program, again for Piranha. It's due out in the middle of 1987 and is so top secret that neither the author nor our fishy friends would tell us what it's called. Our spies tell us, however that it's a licence and uses those massive sprites that have made Don's reputation

● Torus, has finished Hive, an alien swarm game for Firebird. The game takes you into the honeycombed core of the hive where you've got to solve a variety of door-opening puzzles to find and kill the queen bee. Since it was finished Torus, the team responsible for Firebird's Gyron, has split up. One member, Ricardo Pinto, is now working for Rainbird

● Luke Andrews of Vortex, the programming team which produced Alien Highway, and TTL, is three quarters of the way through his next Spectrum release. He says: "It's a space game and that's all I'm prepared to tell you". Cheers, Luke

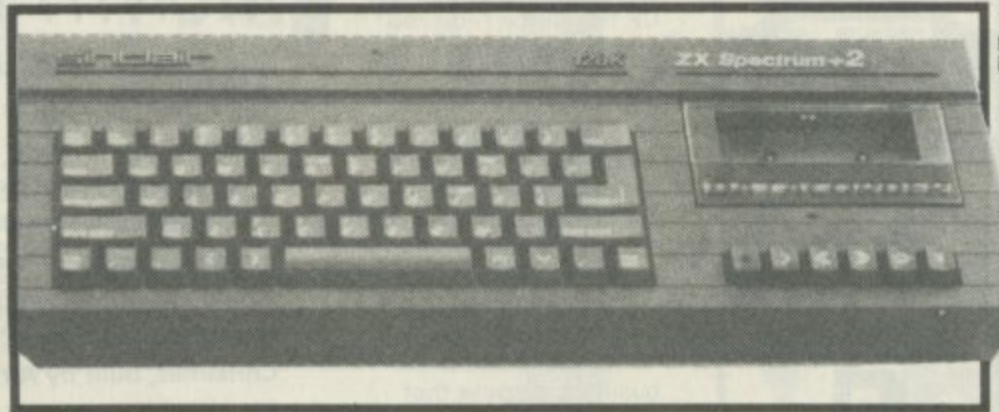

◀ High Street stores may apply pressure on Amstrad to change its 128K+2 joystick 'standard'

Amstrad may yet be forced to change its daft configuration of the joystick port in the 128K+2. A row is brewing over the 'standard' between Boots and Amstrad and the disagreement contributed – along with tape head alignment problems with the machine's built-in tape-player – to Boot's decision to withdraw the 128K+2 from the shelves of some stores last month. The tape alignment hiccup has now been cured and the 128K+2 is back on the shelves but the joystick wrangle rumbles on.

The problem is that Amstrad has twiddled with the pin arrangement in the 128K+2's joystick socket so that only Amstrad's own-brand joystick will work and the Amstrad 'stick' uses the old 'Sinclair' software standard. The Sinclair standard never achieved recognition and most commercial software is written to operate with the Kempston standard. As a result of all this some commercial software available for the 48K machines won't operate from joysticks on the 128K+2.

One of those games is Uridium, from Hewson which is billed as 128K+2 compatible. However, early versions of the game would only work with keyboard control.

A spokesman for Hewson says: "There was a problem with early batches of the game but that's been sorted-out and the new version of the game is fully compatible with the 128K+2 joystick".

Amstrad appears unconcerned with problems of software incompatibility. The company believes that it is the responsibility of the software houses to fall into line and adopt the Sinclair standard.

Unfortunately many software and hardware firms are no longer sure what that standard is!

Meanwhile, though, the 128K+2 is now back in Boots stores, it is thought Boots is applying pressure to Amstrad to reconsider its decision to stick with its non-standardised joystick 'standard' for the machine

## SPECTRUMS TAKE OFF

The computer boom has taken off again! High street stores are now reporting greatly increased demand for machines – compared with last year.

This means the annual Spectrum shortage, which starts at Christmas and chunders into the new year, looks set to be a good deal worse this year with the 128K+2 in very short supply.

Distributors such as ADL and Lightning are finding it difficult to keep up with demand and some orders from independent retail shops are taking more than eight weeks to fulfill.

The problem seems to be occurring at the Amstrad end of the pipe-line and there's little that even the big distributors can do – except wait



## ARCHERS OFF MARK

The Archers, Mosaic's long awaited adventure game version of the slow running radio soap has been threatened with the sheep dip by BBC bosses.

Production was stopped when William Smethurst, the game's co-script writer and editor of the radio

program, left the BBC to join Central Television. The BBC then insisted that Smethurst's name be taken off the game's packaging.

Several days, and £1,000 later, he joined the role of the other Archers characters who have been sent into that great oblivion by the BBC

## STARLIGHT OUT

Starlight is, a new software team set up by ex-Beyond boss Francis Lee.

Greyfall, it's first effort, is an arcade adventure with 3D isometric graphics. It'll hit the high street later this month via a tie-up with the Ariolasoft label. Then comes Deathscape, described by Starlight as a 'space fight simulator', which will be released in February.

Ashley Gray, Ariolasoft's managing director, says: "We are delighted to be working with Francis and his new company. Starlight is sure to become a major new force in the software industry".

We wait with bated breath



## ELITE GAMES DOUBT?

Elite, the publisher of **Space Harrier** and **Paper Boy**, has fallen foul of two major UK software houses over its plans for its 2.99 Classic budget label.

Vortex and CP Software were allegedly promised advanced royalty deals for games to be launched on the budget label. Luke Andrews, a director of Vortex, was approached last year by Elite who agreed to publish **TLL**, **Cyclone** and **Android II** within six months. Vortex agreed but has since heard nothing from the company. Andrews says: "They promised advanced payment on unit sales. We've heard nothing from them since. Why haven't we heard from Elite? And if they haven't been released then why not?"

CP Software is in a similar situation. 2.99 Classics offered to take



four titles – **Backgammon**, **Bridge**, **Chess** and **Draughts** – for the Spectrum and Amstrad computers and was given the same six-month deal with

advances on unit sales. CP has since received some money from Elite, but not what was expected.

Chris Wittington, a director of CP, says: "We've issued a writ".

Elite can either agree to make a settlement or go to the high court to attest the claims of CP and Vortex.

"It's just normal business dispute that will be cleared up in days," says Elite's Steve Wilcox.

He also assured us that, despite claims from the trade press, the 2.99 Classics label was not being disbanded. "We are obviously concentrating on Elite products over the Christmas period, but customers will still be able to get any of the Classics range." Good to know 2.99 Classics cares for its third-party clients over the boom period, Steve.

## TW TMTW THAT WAS THE MONTH THAT WAS

What a year! Easily the most dramatic for Sinclair and the Spectrum since the machine's launch four years ago.

Who would have thought at the start of the year that Sinclair would be bought up lock, stock and barrel by its arch rival Amstrad? And who would have predicted a brand spanking new Spectrum would be in the high street shops this Christmas, built by Amstrad and ready to take the world by storm. Here's a blow by blow account of the most tumultuous year in Sinclair computing yet:

January. Sinclair is seriously strapped for cash and the 128K Spectrum is still unlaunched.

February. Sinclair sells its flat-screen TV to Timex to raise cash to fund the 128K. The machine finally sees the light of day on February 13 March. Claims that the 128 would be 100 per cent compatible with existing software prove to be total tosh. Pandora – Sinclair's portable micro project is rumoured to be Spectrum compatible with discs

April. In a scene of high drama on April 7 Sir Clive announces he has sold world rights of Spectrum and QL technology to Amstrad. Amstrad gets Sinclair for a song – £5m plus £7m for stocks. Sugar announces a new Spectrum will be built, costing around the £140 mark. Sir Clive puts his luxury Chelsea home up for sale to anyone with £1m

May. Sir Clive reveals that, at the time of the sell-out, he was working on two new machines – one a game console the other a souped-up Spectrum with Amiga-like sound and graphics

June. Sir Clive gets interviewed and wishes Alan Sugar luck: "If he can make money then fantastic, but we were losing money and there's no sense in that."

July. A launch date is set for the new Amstrad Spectrum – the 128K+2 – of September 2

August. Sir Clive says he will still go ahead with Pandora, but minus its Spectrum compatibility September. It's here! The best Spectrum ever – the 128K+2. The machine is everything we'd hoped for. It's really neat, with a full 128K and built-in cassette player – all for the incredible price of £149. The only niggle is its daft joystick configuration and the naff bundled software October. Amstrad's profits soar – up 273% November. The 128K+2 finally gets into the shops

December. The new Spectrum is set to sell well over 150,000 machines over the Christmas period. It's still the best selling machine by far and it's still got the finest selection of software available for any machine. Four years on and it's still the greatest. Beat that, Commodore!

## ADD-ON KEYS FOR QL

A long awaited replacement keyboard for the QL has been launched by Schon Keyboard, a company run by ex Saga sales manager Chris Smith.

The keyboard comprises two units, the keying unit and the replacement housing. The former has 64 black keys with a full-sized space bar. The new housing has been kept similar to the original QL housing so all peripherals remain compatible. No soldering is required and, the company claims it will take five minutes to fit.

More information on the £54.95 keyboard



can be obtained from Schon on (04865) 3836.

● Saga Systems is to launch two QL keyboards next month. The more expensive of the two contains an infra-red unit so that you can unplug the keyboard from the computer and still enter

commands. The other keyboard will be similar to Saga's Emperor range. David White, managing director of the company says somewhat competitively: "We haven't fixed a price but it will be less than the keyboard from Schon"

## INFOGRAMES IN COMMAND

Infogrames, who brought you murder mystery **Vera Cruz** and is about to launch **Inheritance**, is yet another company launching a new label this month. The label's called **Command** and it will be exclusively for strategy and wargamers, a hardly-done-by minority in the Sinclair software market. The first release will be **Apocalypse**, a title from Red Shift, a company long-time Spectrum owners will remember. It'll be launched in February at £9.95



## CUT PRICE SOFTWARE

SPECTRUM	RRP	OUR	SPECTRUM	RRP	OUR	SPECTRUM	RRP	OUR
Dan Dare	9.95	6.95	Cobra	7.95	5.50	Infiltrator	9.95	7.25
Superbowl	9.95	6.95	Elite	14.95	10.95	Thanatos	9.95	7.25
Uchi Marta	6.95	6.95	Top Gun	7.95	5.50	Nightmare Rally	7.95	5.50
Space Hammer	7.95	5.50	Dracula	9.95	6.95	Movie	7.95	5.50
Bomb Jack 2	7.95	5.50	Avenger	9.95	7.25	Dark Sceptre	14.95	10.95
Commando 86	7.95	5.50	Masters Universe	8.99	6.50	Laser Basic	14.95	11.95
1942	7.95	5.50	Equinox	9.95	6.95	Cauldron 2	8.95	6.50
Duffell's Big 4	6.95	6.95	Xenious	7.99	5.50	Laser Compiler	9.95	7.25
World Games	8.99	6.95	Aliens	9.99	7.25	Graphic Ad Crea	22.95	18.00
Now Games 3	6.95	6.95	Ex-Fist 2	8.95	6.50	Pynaruse	9.95	6.95
Hardball	6.95	6.50	Trivial Pursuit	14.95	11.95	Lazer Genius	14.95	10.95
Terra Cresta	7.95	5.50	Mag Max	7.95	5.50	TT Racer	9.95	7.25
Sold A Million 3	6.95	6.95	Highlander	7.95	5.50	Scooby Doo	7.95	5.50
Ghost & Goblins	7.95	5.50	Dynamite Dan 2	7.95	5.50	Theatre Europe	9.95	7.25
Galvan	7.95	5.50	W.A.R.	7.95	5.50	Paperboy	7.95	5.50
Great Escape	7.95	5.50	Knight Rider	7.95	5.50	Fairlight 2	9.95	6.95
Parallax	7.95	5.50	Sky Runner	9.95	7.25	Best Of Beyond	9.95	6.95
It's A Knockout	7.95	5.50	Jack The Nipper	7.95	5.50	The Boggit	7.95	5.50
Ace	6.95	7.25	Big Cave Adventure	7.95	5.50	Ice Temple	7.95	5.50
Super Soccer	7.95	5.50	Green Beret	7.95	5.50	Mike	7.95	5.50
Batman	7.95	5.50	Double Take	7.95	5.50	Yie Ar Kung Fu 2	7.95	5.50
Leaderboard	7.95	5.50	Konami's Golf	7.95	5.50	Shao-Lin's Road	7.95	5.50
Miami Vice	7.95	5.50	Urdum	8.95	6.50	Gauntlet	8.99	6.50

(XMAS SPECIAL for Spectrum Users Paperboy & Great Escape £10.00 for the two return this add with your order)

This is just a small selection from our stocks. Please ring for more details. P&P included.

Overseas orders please add 75p per

tape. For up-to-date list's please enclose S.A.E. For mail order please send Cheques/P.O Payable to C.P.S.

Visa/Access orders by phone welcome to:

CUT PRICE SOFTWARE Dept (DEPT 4) Unit 6, STORT HOUSE,  
Riverway, Harlow, Essex, CM20 2DW.  
Tel: (0279) 24433 (24 hr ansaphone)



## OFFICIAL SPECTRUM UPGRADE

Turn your rubber keyboard spectrum into a new spectrum Plus including Spectrum Plus user manual for only £22.75 including P & P.

## EXPANSION PACK

contains interface 1, microdrive, leads and demo cartridge. RRP £99.95. Excluding user guide £44 plus £3 p&p. Including user guide - £45 plus £3 p&p

**W.A.V.E.** (mail order)

Walney Audio Video & Electrical  
53 Shearwater Crescent, Barrow-in-Furness,  
Cumbria LA14 3JP. Telephone: 0229 44753

## Strategic Warfare for

### SPECTRUM 48K

WAR IN THE EAST ★

£9.95

FALL of the THIRD REICH

£9.95

ARDENNES - Battle of the Bulge

£9.95

BRITAIN INVADED

£9.95

These military strategy and tactics  
games for 1 player

SHARP'S INC  
Rt 10, Box 459  
Mechanicsville, VA23111 USA  
Telephone (804) 746-1664  
Telex (via WUI) 6502339544

T. K. COMPUTERWARE  
Stone Street  
North Stanford  
Ashford, Kent TN25 6DF  
Telephone 0303-812801  
Telex 966676 PMFABG

Payment by cheque, PO, Eurocheque, or by

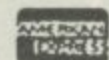
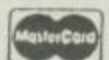

# THE AWARD WINNING GRAPHIC ADVENTURE CREATOR



Will change the face of the  
adventure software market.  
AMSTRAD ACTION

THE ANSWER TO YOUR PRAYERS!

C&VG

A very clever utility . . .  
very easy to use.

KEITH CAMPBELL, COMMODORE USER

Highly recommended.  
ACORN USER

A very impressive and  
sophisticated adventure generator.  
SINCLAIR USER

Now everyone can write professionally  
illustrated adventure games.  
The Graphic Adventure Creator - THE  
adventure writing utility of the eighties.

\* Unleash the Power of your imagination \*



AVAILABLE AT ALL  
LEADING RETAILERS  
or direct from:  
INCENTIVE  
SOFTWARE LTD.,  
2 Minerva House,  
Calleva Park,  
Aldermaston,  
Berkshire RG7 4QW.  
Telephone: (07356) 77288.

PLEASE RUSH ME (1st Class Postage FREE)

THE GRAPHIC ADVENTURE CREATOR

Tape £22.95  Disc £27.95

Winter Wonderland graphic adventure . . . . . £7.95

Apache Gold (Except BBC B) . . . . . £7.95

The GAC Adventure Designer Pad . . . . . £7.95

SPECTRUM  COMMODORE 64  AMSTRAD CPC

BBC B  GAC extra information - free with any order

I enclose Cheque/P.O. for £ \_\_\_\_\_

or please debit my credit card No. \_\_\_\_\_

Name \_\_\_\_\_

Address \_\_\_\_\_

# NEWS

## CHEAP DARLINGS



Code Masters, the new Darling of the budget software industry, has proved that there is life after Mastertronic.

Only two weeks after its launch the company ranked amongst the top seven UK software companies, grabbing 2.8 percent of the market with 12 titles across three formats. The company's two top programmers, David and Richard Darling, used to work for Mastertronic while their father, Jim, acted as MD of AI Products, the company responsible for sourcing Mastertronic's games

◀ Code Masters  
▼ Terra Cognita

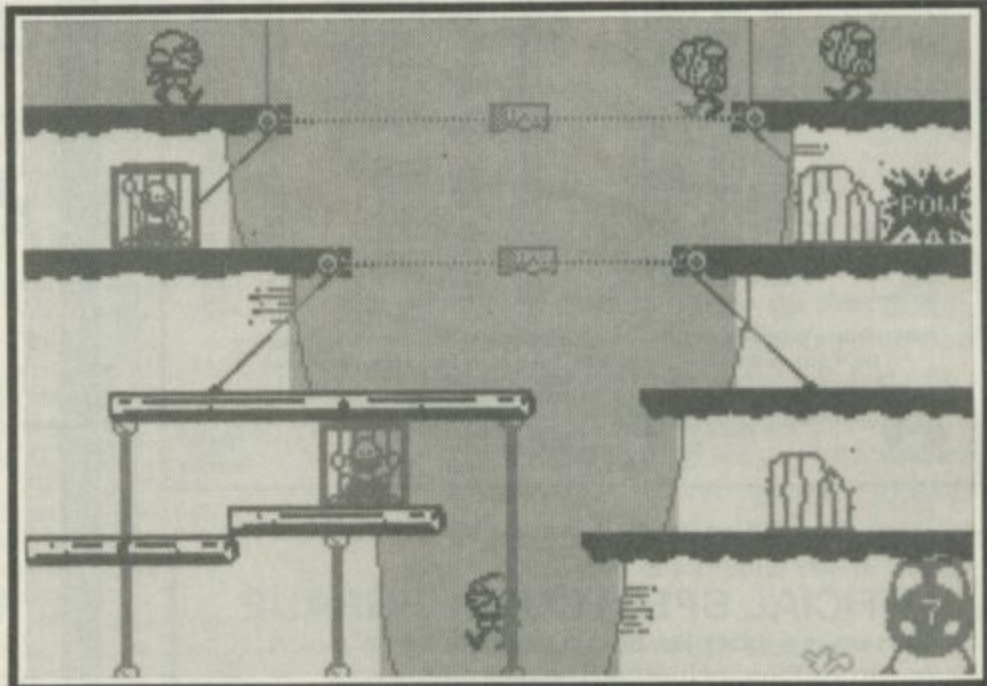
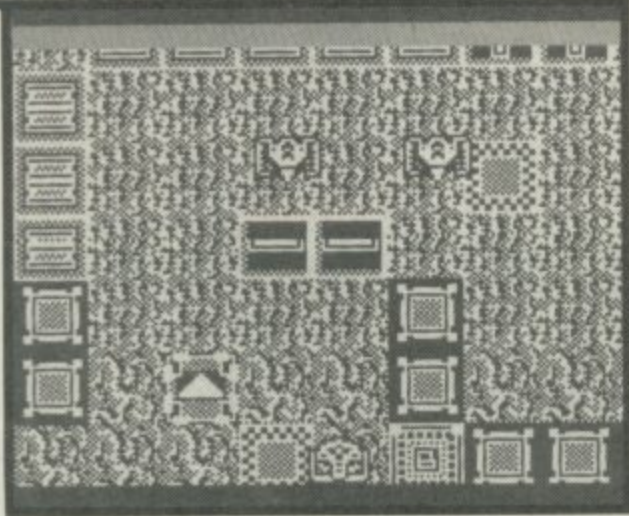

## ADVANCE FOLLOW-UP BUTCH HARD GUY

Advance Software, still fresh from its success with **Hardball** will bring out something enigmatically called **Butch Hard Guy** this month.

The arcade game was programmed by Future Concepts who last year made a splash with the **Surf Champ** surfing simulation. It's a levels and ladders game in which you play a tubby

commando who's mission is to rescue a group of prisoners who are in the hands of the evil Mr Foo.

**Butch** is for the 48K Spectrum and will cost £7.95

## NET NETS £25,000

Micronet 800, the multi-user information database, has raised more than £25,000 for BBC TV's *Children in Need Appeal*.

As Micronetters used their modems to pledge money, interviews with film and television stars were broadcast live from Shepherds Bush television studios over the net. The stars included Christopher Reeve, of *Superman* fame, Charles Dance



who was at one time rumoured to be the new James Bond, and three regulars from *East Enders*.

A charity auction in which almost all the UK computer manufacturers took part netted £6,000 of the total money pledged. Chris Bourne, who compiles the micronet gossip column *Slasher*, was delighted with the news: "We had a great response. The only company who refused to contribute was Amstrad".

No doubt that great British institution Alan Sugar had other problems on his mind, see the 128K+2 compatibility story

◀ Chris 'n' Charles

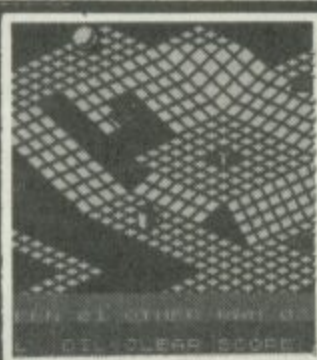

## ARTS IN THE UK

Electronic Arts, the massive stateside software house responsible for many of Ariolasoft's C64 and Amiga titles - including **Marble Madness** - is to launch its own British label and plans Spectrum versions of its new programs.

The company looks set to emulate Activision and UK newcomers Micro Prose and Konami, all US firms who have opened up over here. Electronic Arts is also looking for an MD to head its UK division. Current favourites include Hugh Rees Parnell, ex-supremo of Activision UK. Small world.

## TWO NEW LABELS FROM VONSOFT

Vonsoft, a new game house based in Kent, launches two software labels this month.

Vonsoft itself will produce budget titles, to compete with Mastertronic and Code Masters, while its second label, Frozen Image, will release full price programs.

The first full price

game is **Arena**, at a modest £4.99. It's a graphic adventure which has the hook of cash prize competition.

If **Arena** is successful Vonsoft will launch yet another label, Adventure Reknown, in February for adventure fans.

If they go on like this they'll have more labels than programs!

## ROTRONICS BROKE

Rotronics, the manufacturer of the Wafadrive, has gone into liquidation. Despite a recent creditors meeting no one has come forward to buy the company. However, Rotronics hopes to

fulfill existing orders with remaining stocks.

Anyone with an outstanding order should contact the official receiver, Leonard Curtis and Co, at 30 Eastbourne Terrace, London

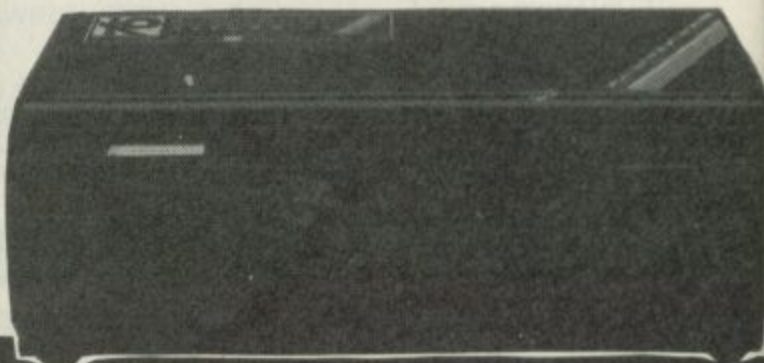

# Memodisk QL

The ultimate expansion for your Sinclair QL

"It is perhaps the best value interface on the market at the moment." Sinclair User  
September 1986

Features of the Memodisk are:

**DISK INTERFACE** - Add up to four 3.5" or 5.25" disc drives (may be mixed). Intelligent controller works out the maximum speed at which the drive can be used - no jumpers to set.

**ADDED MEMORY** - Available as 256K or 512K (256K systems can be upgraded later by the user if required). Provides more memory for Quill and other Psion packages and speeds up overall operation by up to 30%.

**UTILITIES** - Comprehensive range of utilities with 70 additional commands. Includes ram disc, file management commands, non-destructive windows, icons, true multi-tasking (allowing Psion packages to operate concurrently in memory and switching between them), print spooling, job control, function key control, creation of additional screen fonts, and fully controllable screen dumps.

**PRINTER INTERFACE** - Parallel printer interface allows easy connection of a wide range of printers. Printer cable is provided free with 256K and 512K Memodisks.

All products are covered by a 2-year guarantee against defective manufacture

## UK DEALERS :-

**Strong Computer Systems - 0267 231246**

**TK Computerware - 0303 812052**

**D.S. Enterprises - 01 671 0209**

Utilities EPROM £14.95

Printer cable £14.95

256K Memodisk £199.00 including utilities EPROM

512K Memodisk £249.00 and printer cable

Price include V.A.T. and delivery

ORDER FROM:



**MICRO CONTROL SYSTEMS LTD**

**ELECTRON HOUSE, BRIDGE STREET, SANDIACRE,  
NOTTINGHAM NG10 5BA TEL. 0602 391204**

## MAKE PICTURES...

On 48/128/Plus and now available for the 128+2. The superb Trojan CAD-master lightpen and software with all features plus reliability.

Highly acclaimed in reviews-the screen is your canvas. Full colour masterpiece or simple line drawing, you are limited only by your imagination.

\* Freehand write/draw \* Circle, box, triangle, lines, banding, rays \* Quills, \* Copy, \* Enlarge, \* Text, \* Fill colours or patterns \* Window \* Printout, \* Save/load to microdrive or tape etc. All this and more for only **£19.95** (inc p&p in UK add £1.50 overseas)



## MAKE MUSIC...

On 48/128/Plus/128+2 with the incredible MUSIC MACHINE by RAM. The complete home computer music system with MIDI in/out/through. Compose your own songs, tunes, rhythms using the built-in sounds or mix with your own. Can be made to sound similar to any instrument. Includes eight drum sounds. As shown at PCW Show - rave reviews - (Sinclair User Oct '86) you must get one for only **£49.95** inc. p&p UK and £2. overseas



Trade and Export Enquiries Welcome

## COMPUTER CUPBOARD

Freepost LONDON W5 1BR (SU1/87)

Please supply Light pen 48/plus/128 **£19.95**  
Light pen for 128 + 2 **£19.95**  
Music Machine **£49.95**

Name .....  
Address .....  
Postcode.....

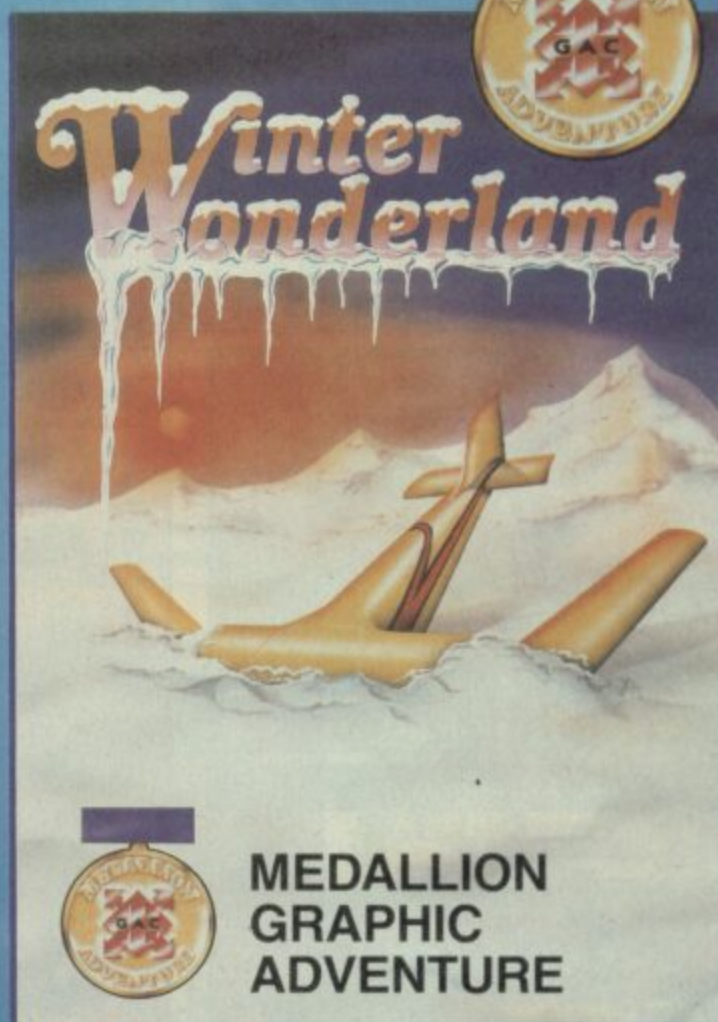

**MEDALLION GRAPHIC ADVENTURE**

Breaking through the dense cloud cover you were relieved to see a dazzling white snowfield spread below you. Desperately preparing for a crash landing, you were distracted by a glint of sunlight on glass - a building! Could THIS be the lost civilisation?

Your attention however was drawn back to the ground hurtling towards you...

From the producers of  
**THE GRAPHIC ADVENTURE CREATOR**

AVAILABLE FROM ALL LEADING RETAILERS or direct from:  
**INCENTIVE SOFTWARE LTD.,**  
2 Minerva House, Calleva Park,  
Aldermaston, Berkshire RG7 4QW.  
Telephone: (07356) 77288.

### **PRIORITY ORDER FORM**

Please rush me for my: Commodore 64   
Spectrum  BBC B  Amstrad CPC   
**WINTER WONDERLAND** **£7.95**   
Apache Gold (except BBC) **£7.95**   
Graphic Adventure Creator { Tape **£22.95**   
Disc **£27.95**   
I enclose cheque/PO or please accept my credit card No. \_\_\_\_\_  
Name \_\_\_\_\_  
Address \_\_\_\_\_



▲ In the top slot: Paperboy Oct SU Tip for the top

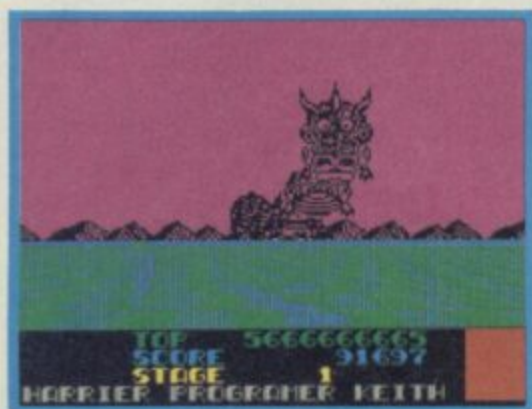

▲ Tip for the Top: Space Harrier



▲ Longest on the Chart: Ninja Master

1	(1)	PAPERBOY	ELITE	£7.95
2	(5)	OLLI AND LISA	FIREBIRD	£1.99
3		<b>NEW!</b> THE GREAT ESCAPE	OCEAN	£7.95
4	(3)	LIGHTFORCE	FASTER THAN LIGHT	£7.95
5	(7)	TRIVIAL PURSUIT	DOMARK	£14.95
6		<b>NEW!</b> INFILTRATOR	US GOLD	£9.95
7		<b>NEW!</b> URIDIUM	HEWSON	£8.95
8		<b>NEW!</b> DANDY	ELECTRIC DREAMS	£7.99
9	(15)	NINJA MASTER	FIREBIRD	£1.99
10		<b>NEW!</b> 1942	ELITE	£7.95
11	(4)	KAI TEMPLE	FIREBIRD	£1.99
12	(14)	HEAD COACH	ADDICTIVE	£8.95
13	(18)	HAPPIEST DAYS	FIREBIRD	£1.99
14		<b>NEW!</b> COMPUTER HITS VOL 3	BEAU JOLLY	£9.95
15	(2)	DRAGON'S LAIR	SOFTWARE PROJECTS	£9.95
16		<b>NEW!</b> TRAP DOOR	PIRANHA	£7.95
17		<b>NEW!</b> 180	MASTERTONIC	£1.99
18	(9)	ACE	CASCADE	£9.95
19	(10)	NIGHTMARE RALLY	OCEAN	£7.95
20	(17)	BOMB SCARE	FIREBIRD	£1.99

## HOTTEST CLIMBERS

Hottest releases this month: **Avenger** from Gremlin may get viewed as a Gauntlet-like, but it's a good deal better and more complex than that; **Fairlight II** is the follow-up to The Edge's earlier Bo Jangeborg

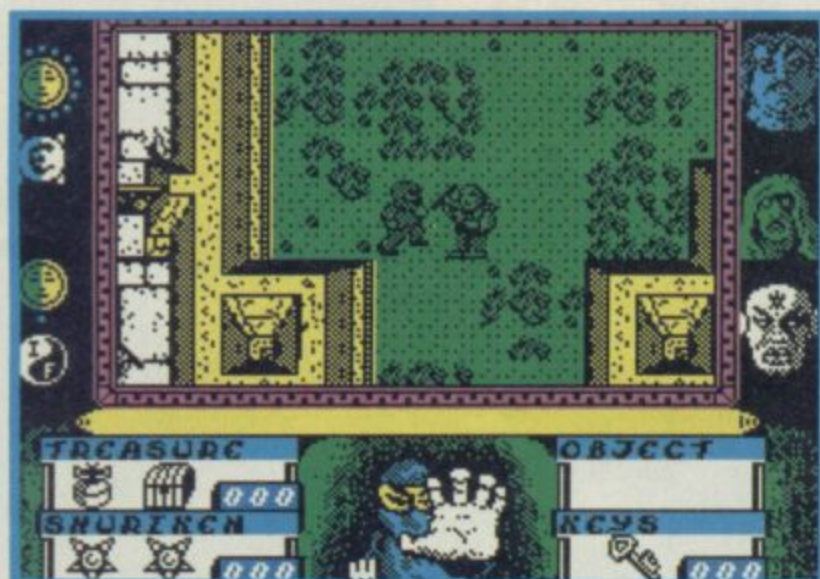

▲ Hot: Avenger



▲ Hot: Fairlight II

# E \* N \* T \* Y

Compiled by Gallup  
for *Sinclair User*

Excellent conversion. Inevitable hardware restrictions make the game less 'special', but it's still great ★★★★★

A graphically good but dull pot-boiler with cute characters. Predictable but well-executed ★★★★★☆

The best thing Ocean's done for ages. Highly imaginative plot, gameplay and graphics. Don't miss it ★★★★★

The ultimate blaster. This one is mindless destruction at its very best. An essential purchase ★★★★★

It's THE yuppie board game conversion. Against all odds it's a terrific effort with sound and graphics questions added ★★★★★

A bit like being in an action film – not a brilliant one though. Arcade meets strategy meets adventure ★★★★★

Superb arcade game. Smoother, faster, slicker and more challenging than almost anything else you could buy ★★★★★

Astonishingly authentic conversion of what is effectively Gauntlet. The two-player option is an incredible game ★★★★★

Poor quality. Not the Exploding Fist type game it may seem. Avoid it if you can ★☆☆☆☆

A simple idea, simply programmed. But the gameplay is gripping. A taut aerial dog-fight drama for all Red Barons ★★★★★

A kick in the teeth for all martial arts fans. Flat graphics and flimsy plot. A let down even at budget level ★★☆☆☆

A must for all sports simulation fans. If you thrilled to Football Manager this is for you ★★★★★

Wally meets Skool Daze runny, jumpy, collecty thing. Cheap but has little originality ★★★★★☆

Latest in Beau Jolly's ten-packs of back catalogue. Pick up on the ones you missed for a pound a piece ★★★★★☆

A big disappointment, having neither stunning graphics or exciting gameplay... And the multi-Loads are a pain ★★★★★☆

As original to play as it is to look at. One of the most imaginative games of the year ★★★★★

Could have been boring and tedious. Instead it's funny, exciting and impressive. A closet hit ★★★★★

Fine flight simulator. Not much detail to get in the way of blasting things at speed ★★★★★

Four-wheeled fun with accent on fantasy. Easy to start but difficult in higher levels ★★★★★☆

Highway Encounter crossed with Knightlore. Excellent graphically and the dull plot is revived by the budget tag ★★★★★

## CHART ★ ★ ★ ★

### BREAKDOWN

1	PAPERBOY	ELITE	ARCADE ★
2	THE GREAT ESCAPE	OCEAN	
3	LIGHTFORCE	FASTER THAN LIGHT	
4	INFILTRATOR	US GOLD	
5	URIDIUM	HEWSON	

1	VERA CRUZ	INFOGRAMES	ADVENTURE ★
2	JEWELS OF DARKNESS	RAINBIRD	
3	AFTER SHOCK	INTERCEPTOR	
4	PRICE OF MAGIK	LEVEL 9	
5	HEAVY ON THE MAGIK	GARGOYLE	



▲ Uridium



▲ After Shock



▲ Pub Games



▲ Graphic Adventure Creator

1	TRIVIAL PURSUIT	DOMARK	STRATEGY SIMULATION ★
2	HEAD COACH	ADDICTIVE	
3	ACE	CASCADE	
4	TT RACER	DIGITAL INTEGRATION	
5	PUB GAMES	ALLIGATA	

1	ART STUDIO	RAINBIRD	WORK-OUT ★
2	WHAM! THE MUSIC BOX	MELBOURNE HOUSE	
3	THE WRITER	SOFTTECHNICS	
4	GRAPHIC ADVENTURE CREATOR	INCENTIVE	
5	DATA GENIE	DATABASE	

1	OLLIE AND LISSA	FIREBIRD	BUDGET £1.99 £2.99
2	NINJA MASTER	FIREBIRD	
3	KAI TEMPLE	FIREBIRD	
4	HAPPIEST DAYS	FIREBIRD	
5	180	MASTERTRONIC	

classic – this one's more of the same with even more difficult puzzles; **Terra Cognita** is set to be the first hit from Code Masters, the new budget team which has just spun off from Mastertronic – it's a bit like Lightforce only a whole lot cheaper

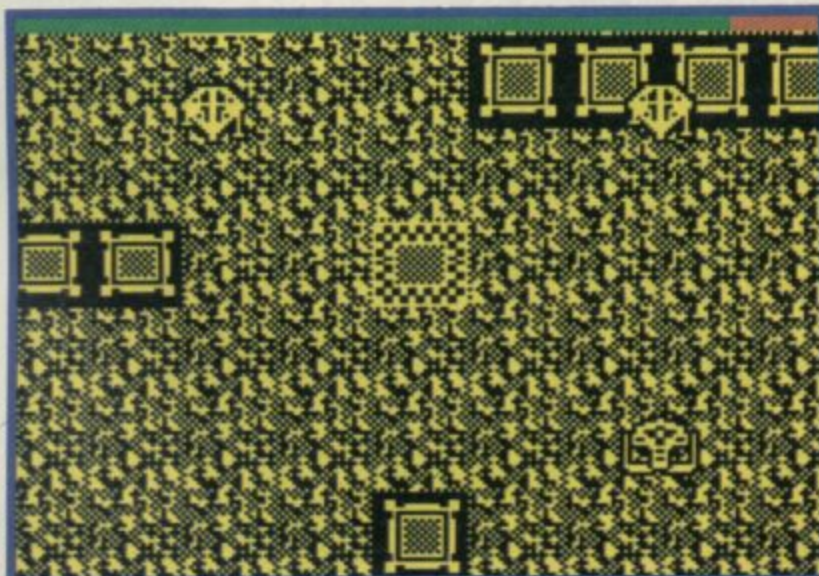

▲ Hot: Terra Cognita



ocean

DIGITAL INTEGRATION   
ACTIVISION  
HOME COMPUTER SOFTWARE

They sold a

# MILLION

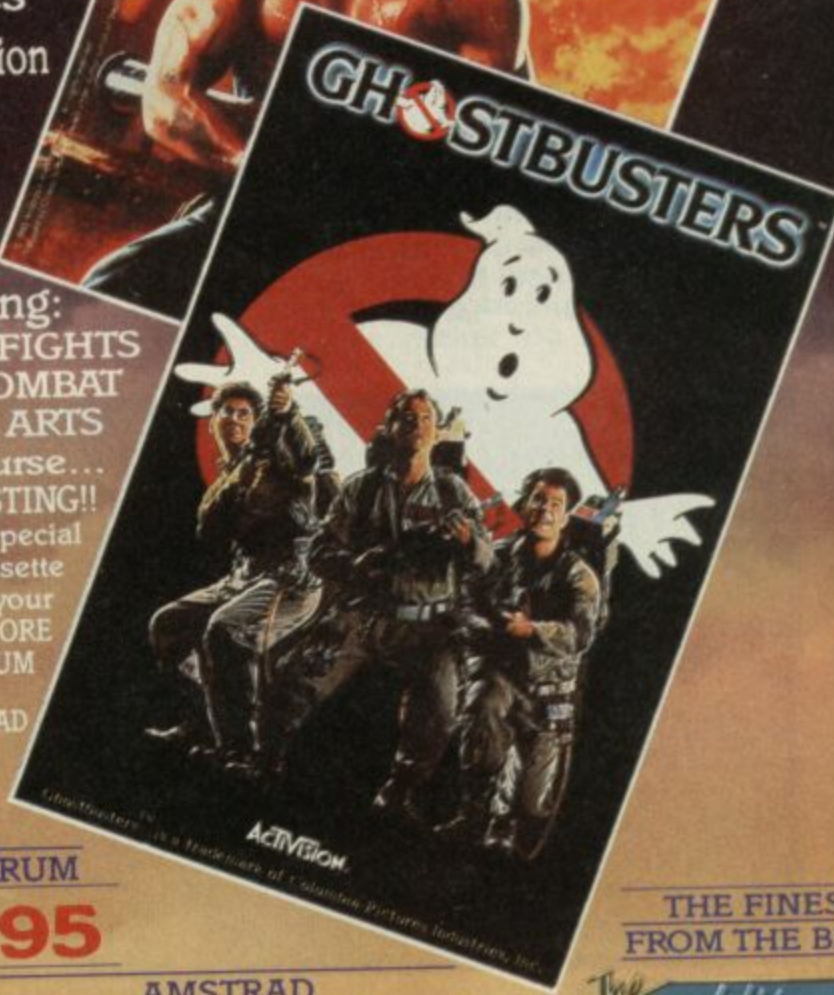
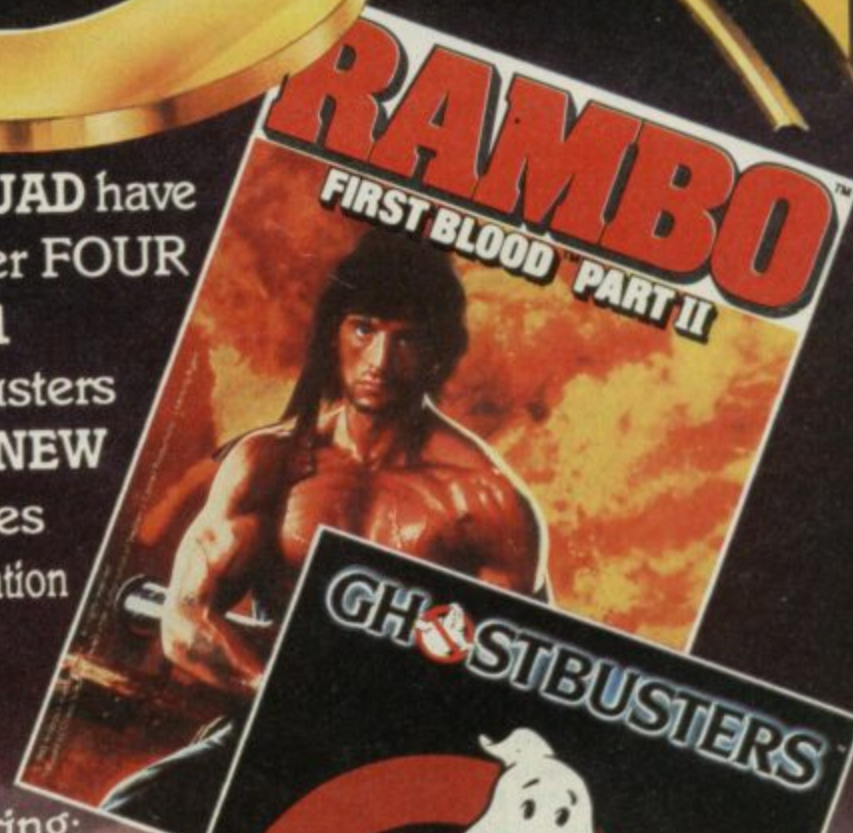

The **HIT SQUAD** have put together **FOUR** **No.1** Blockbusters for this **NEW** games compilation

Featuring:  
ARIEL DOGFIGHTS  
JUNGLE COMBAT  
MARTIAL ARTS  
and of course...  
GHOSTBUSTING!!  
All in one special twin - cassette pack for your **COMMODORE SPECTRUM** or **AMSTRAD**

SPECTRUM  
**£9.95**

FROM ALL GOOD SOFTWARE DEALERS

COMMODORE

CASSETTE

**£9.95**

DISK

**14.95**

AMSTRAD

CASSETTE

**£9.95**

DISK

**14.95**

THE FINEST FROM THE BEST



# LETTERS



Well, it seems as if old Wriggles has done it again. I was not aware that address 562789 was accessible on my Spectrum 48K, but, according to 'Sap Chat', if it did exist, *Poking* it to zero would enable O'Donnel to get past the skulls in the second stage of *Pyracurse* without being changed into what looks like something which Fozzie could have done.

Needless to say, it does not work. When Jon has saved up enough luncheon vouchers, I suggest that he buys an old fashioned, flat keyboard, useful-as-a-door-wedge 48K Spectrum and actually types in every listing or *Poke* which he prints so that he can find out how the rest of us feel.

By the way, I think that SU has bottomed out with regards to quality with the timely departure of old incorruptible. The hour of liberty was marked by profanity in the *News* column and the mention of Fungus McNeill in every issue since which would suggest that the new editor is either mad or still cannot get out of the goblin's dungeon.

On the whole, though, I think that the quality of the mag has improved, despite the 'Highly Demented Communist Prats'.

The new articles are great, so all you've got to do now is get rid of the 'Greatbelly Clue Matrix Thing', the Mad Celt's red biro (see Issue 56 page 113 to find out why), Jon Wriggles and whoever makes all those spelling mistakes.

**R W Miles**  
Dorset

● *Should we force this upon our readers? We don't know. How shall we deal with this lunatic? OK, thanks for your comments, they have been noted: the magazine has bottomed out but is improving every issue. What!?*

## You PAW thing

I have been reading the December issue of SU (creep! creep!) and saw the preview for the **Professional Adventure Writing System**. Up till now I have been telling everyone I would like the Incentive **Graphic Adventure Creator** but now I don't know which one would be better.

I suppose I am mostly interested in the graphics capabilities but hopefully you have reviewed PAW and could advise me which of the two is a better 'all round' buy.

**Jainta Woodbridge**  
Adventure freak  
Surrey

● *Go for the PAW - it's much better, (according to John) although it's not available yet and it's certainly more fiddly to use on a 48K machine - it's really designed for the 128*

## Dream machine

I believe Loki and Loki-like machines are destined to be the 'in' computers in the near future. The company which brings one out first is sure to be the trendsetter, and all the others would soon follow suit.

To keep the British home computer industry ticking, Amstrad and Sinclair Research should jointly produce the machine, otherwise, the Far Eastern tidal wave would obliterate them and make another black-watch debacle out of this industry. So please don't kill this dream computer, Mr Sugar 'n' Sir Clive.

Lastly, the mag SU's improving. The splash of colours makes it livelier and easier to read (good work Gareth!). Zap Chat is still boring, discontinue it and instead, every second month bring out a supplement with readable no-nonsense maps, hints and *Pokes*. Lately, programming-technique articles are missing? Reviews are OK! Graham Taylor is good and thank God, Ms Edgeley at last been edged out!!!

**Tomal H Zaman**  
Karachi  
Pakistan

PS Gremlin I love your sarcastic caustic & sizzling gossips.

● *Ms Edgeley is about to send those Rainbird boys around to set you straight. Gremlin said something witty but we couldn't work it out*

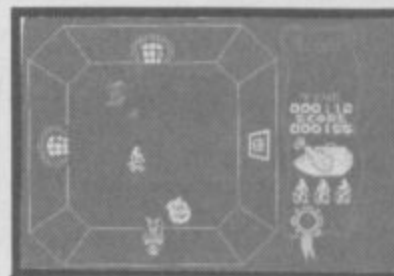

## 128K+2 compatibility?

Please could you tell me if old 48K games such as *Atic Atac* and *Jet Pac* will work on the new 128K Spectrum, because I am hoping to get one next year.

**Philip Hendrick**  
Sheffield  
● *Most of them will work, but it's so hard to tell - they may only crash on one of the higher levels*

## Learning into the curve

With reference to the letter from Carol James of Reading, published in the November issue of SU I can provide educational software for use at home or in schools, covering the age range of 4 to 8+ years.

I have three main series of programs, Maths, Language and Games. They are available on cassette, Microdrive or Opus disc.

A further three series, covering the same age range, and in the same formats, are made for use with the Starset Concept keyboard.

I can also prepare programs for use by handicapped children, and this can usually be done without extra charge.

**Brian Seymour**  
25 Chatsworth Gardens  
Scarborough  
North Yorkshire

I have just seen your request for information on Educational programs printed in the November issue of SU and thought I might be able to help.

There are, in fact, a large number of excellent educational programs for the Spectrum but getting hold of them is not always easy. My wife (who is a primary teacher) and I have found the best venue is at ZX Micro Fairs.

If anyone would like a brief run-down of the program we have purchased and what value my wife puts on their educational value I will be happy to send one if you enclose an S.A.E.

**John Manley**  
19 West Ley  
Burnham-on-Crouch  
Essex

## FACULTY ENTERPRISES LTD

PRESENT

Trivial Pursuit	12.99
Elite 48k	9.15
Paperboy	5.99
Ghostbusters	5.99
Vat Manager (ocp) 48k	5.99
Address Manager (ocp) 48k	5.99
Finance Manager (ocp) 48k	5.99
VAT Manager (ocp) 48k	9.95
Finance Manager + 80 48k	9.95
Address Manager + 80 48k	9.95
Stock Manager + 80 48k	9.95

Send SAE for List. Cheques and P.O.'s payable to:

**FACULTY ENTERPRISES LTD**

7A Sherwood Crescent, Market Drayton, Shropshire  
PHONE:-0630 57465

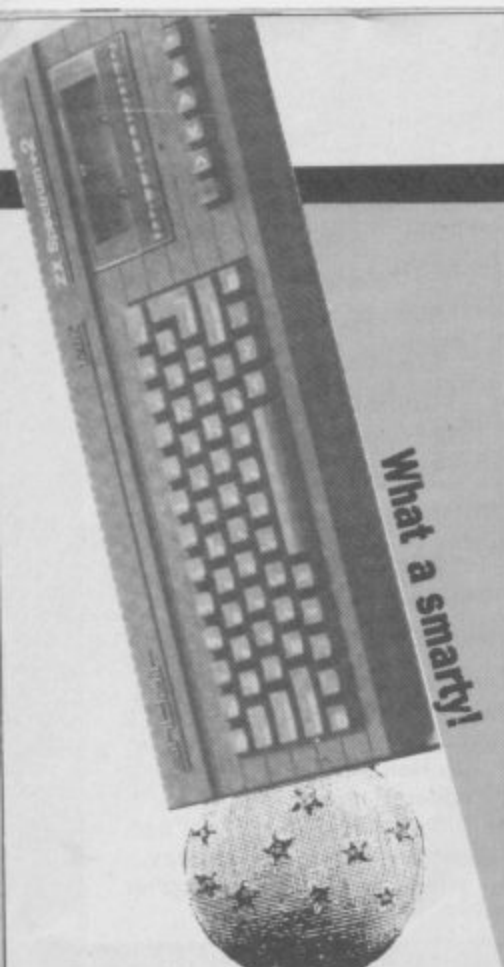

What a smarty!

Why, oh why didn't Amstrad put a tape counter into the 128K+2. Having bought a 128K+2 a few days ago and being totally impressed with its capabilities, I was just a bit miffed not being able to find any of my self-penned programmes on C90's.

Opening it up I found ample room below the Spectrum logo for a miniature counter and the left-hand tape spool has a vacant drive wheel. So I fitted one in less than 2 hours from scratch, with no decrease in speed or performance.

This invalidates the guarantee but it's probably better to take it to the local specialist for quick cheap repair (in the event) than have it lost by some big chain store anyway

**Bob Dennis**  
Cornwall

● *Who oh why are some people just so, erm, 'together'? You've obviously got the problem licked, Bob. Have any other readers done clever things with their 128K+2?*

## Start here

I have just bought a Sinclair 128K+2 and would welcome your advice on the following.

I find that the manual assumes you understand computing terms and wondered if there is, or will be soon, a publication using laymen's language that will assist me to understand the workings of my computer.

It appears that most of the games require a joystick and that the 128K+2 is wired so that it will only take Sinclair joysticks. Could you recommend an interface (adapter?) and a joystick that will enable me to play the

## Warsaw or Walsall?

I was looking through your comic one day when a leaflet fell at my feet. I picked it up and found it was for the all new **SU** (now with no artificial colourings and preservatives). I therefore bought the magazine (for the 51st time to be correct) and I liked what I saw except the new logo.

It took me 10 minutes to find as it looked exactly like the logos that the comics use: No 1, Smash Hits and other assorted toilet roll brands).

One bad thing, who the hell is this prat, Michael Wilson? He sounds suspiciously like a comic. I think you've mucked up his address again, as I think his first letter was full of \*\*\*\*. Are you sure it isn't Warsaw instead of Walsall??? His writing is of course bad, they don't let him use sharp

instruments, only crayons in his funny farm. And I think James Baldock should be careful because Mick isn't after him with a Commode logo, it's a hammer and sickle and if James isn't cautious he could end up like Micky Gorbachev.

On the subject of James Baldock he seems to be quite an intelligent chap and a good letter writer as I have seen his pearls of wisdom all over **SU**.

But I'd better come clean, I've only written this letter because I didn't see the wave of comment on my first letter (September '86), probably because it was right beside Baldock's letter, just my luck! So I hope this little number is nice and controversial.

**Adrian Walker**  
Cork

● *You are obviously completely insane*

games available in shops.

If I purchase an interface will I be able to use any joystick with it?

Finally, is there any possibility that your magazine will be having articles aimed at the 128K+2 or at the beginner to computing?

**L Brown**  
Manchester M16

● *Look out for next month's pull-out feature on beginning with the 128K+2. As far as joysticks go, your best bet is to buy a Kempston standard interface and plug it into the back of the computer. You should be able to make it work*

## Pah! Some threat

I can't say I'm over the moon about the new mag, after all, there can't be that many films being turned into rip offs each week.

But down to the real point of the letter.

Who ever recommended Graham Taylor to the 'editorial committee' must own a Commodore. Firstly, he gives **TT Racer** (the best racing simulation ever) only four stars and complains of lack of realism in the graphics. Has he ever tried looking closely at the bikes as they bob, weave and lean over at the turns? Has he ever seen a racing game where if you step on the track and pull in to one side you can see the bikes racing on another part of the track? (Try it on Track 4)

Also, in his so-called joystick top eleven, he manages to give some joy-sticks 'Defensive Systems' like the Speed King, while others have 'Defensive Shields' like the Gunshot 2. Anyway why does he include

another part of the track makes it a realistic simulation (which is what I said). It don't make the graphics great.

As to joysticks that were and weren't included there was a concious attempt to include old and new sticks and a variety of types. There are plenty that might have gone in but couldn't. The Quickshot I did go in because zillions of people may well end up with one as part of special deals in Dixons etc etc and thus want to know about it.

Thanks for the warning,  
David.

## I've been shopped

I would like to make a complaint about Dixons as I think they give the worst service out of all the shops... When my interface broke down I took it to Dixons to be replaced and when I got there they didn't even know what it was. When I explained they made me wait half an hour and made me go home without the new interface. A week later I returned and it still hadn't arrived. They said it would be there in about a month and when I returned in a month they still hadn't got it. And so I asked the assistant if I could see the manager. He said that the manager was on holiday and would be back in a week. I went back there a week later and as usual I handed them the receipt. They made me wait twenty minutes and then they said they had lost the receipt and handed me a piece of scraggy old paper with 'Dixons' written on the top in red, and 'interface' in handwriting. I returned a couple of months later to find that they had at last got a new interface especially for me.

**Robert Lenson**  
London

● *If you are having problems with a shop at the moment let us know - it would be interesting to see if one chain comes out markedly worse than the others*



the ageing, but tough and reliable, Quickshot I without including the Quickshot II (the Father of the Auto-Fire) and Quickshot II Turbo, its redesigned counterpart?

So, G.T. you have been warned, and I hope you enjoy the flood of letters I will unintentionally cause.

**David Jenkins**  
London

PS Keep out Jon Riglar

● *G.T. replies: Dear me, such vitriol. Realistic graphics on TT Racer? It's in the eye of the beholder I guess but the fact that you can see them racing on*





# C.O.O.D.E

**ANITA SINCLAIR**  
AGE 24

"The first computer I saw was probably a Nascom at my friend's house. I was 17 and I wasn't thrilled. I learnt to program using books mostly things like Adam Osborne's *An Introduction to Micro Computing* and the Radio Shack manual. I just fiddled about beginning with something like *For A=1 to 100, Print "hello"*. Later on I probably remembered to put a *Next* at the end.

The thing I wrote which I am proud of was *Grin Wars* an arcade game for the QL. I wasn't pleased with it at the time, but now I think it's pretty good.

## VITAL DETAILS

Which other programmer(s) do you admire?

**I don't tend to know names but I like Realtime - Starglider is an incredible achievement - Ram Jam, Gargoyle and Infocom**

What is your favourite program?  
**Well it might be an**

**ANITA Sinclair, is female and a programmer. This is a very unusual thing. Her fame(ish) is almost totally to do with a) having the surname as a well-known industry figure and b) having introduced the world to The Pawn, a mega adventure running on at least 500 different computers (Really? Ed. No not really). It has just been converted to the 128K. We asked Anita about western civilisation. Here's the dirt.**

**assembler or something but as a game I guess it would be Castle Wolfenstein**

What arcade game do you get the

highest scores on?

**Rearguard, it's an Apple II game**

What program would you most like to have written?



# T.O.A.L.O.K

**The Spectrum version of Starglider**

Your single greatest programming achievement?

**The graphics compression on the Atari ST version of The Pawn**

Favourite TV program

**Fawlty Towers**

Favourite Movie

**Up in Smoke, The Blues Brothers or Life of Brian.**

Favourite Record

**Mahler's First Symphony**

Favourite Book

**Alice in Wonderland**

Worst subject at School

**History**

Worst program that was a hit?

**Ghostbusters**

Hobbies

**I strip floors, read books and drive**

Favourite thing about the Spectrum?

**It was good for its time in quite a lot of ways (that's an answer?)**

Worst thing about the Spectrum

**You can't page off the Rom**

**SOFTOGRAPHY:  
GRIM WARS (1984)  
THE PAWN (1986)**

**He is known to all of you. His successes and his excesses are legendary. But how much of the legend of 'Uncle Clive' is fact, and how much is very potent myth?**



## SINCLAIR AND THE 'SUNRISE' TECHNOLOGY

**Ian Adamson and Richard Kennedy**

A startling and controversial look at the myth of the man once hailed as the messiah of the new Micro-Age.

In Penguin  
£3.95



# LOTHLORIEN



**NEW!!**

## DEATH IN RUSSIA 1941

- German invasion Operation Barbarossa
- All graphic 1 player wargame
- Scrolling Maps
- Simulates Eastern Front 1941-43
- Retail Price only £7.95

**NEW!!**

## DEATH IN THE SNOW 1812

- Napoleon at Borodino
- Sequel to Waterloo and Austerlitz (Crash Smash)
- 1 player all graphic wargame
- Features separate artillery units
- Intelligent corps commanders etc
- Retail Price only £7.95

Available from all good software shops or direct by Post.

**Special Mail Order Offers (Spectrum)**

Waterloo £6.95 normally £9.95

Austerlitz £9.95 + free game

Overlords £5.00 + free game

M C Lothlorien Ltd, Icon House, 381 Bury New Road, Prestwich, Manchester M25 5AW 061-773 1068

Please send me: \_\_\_\_\_

I enclose a cheque/PO made payable to M C Lothlorien Ltd

Please debit my Access/Visa No. \_\_\_\_\_

Signature \_\_\_\_\_

Name \_\_\_\_\_ Address \_\_\_\_\_

Post Code \_\_\_\_\_

M C LOTHLORIEN LTD, Icon House, 381 Bury New Road, Prestwich Manchester M25 5AW  
Tel: 061 773 1068

**T**he Phasor One isn't particularly cool. It sits around looking pretty dull and generally old.

In fact, it's quite a natty little number. The plastic is robust, and the fire button is in a really convenient place.

It feels, somehow, just right and the balance is good.

The only problem is that the stick on top sometimes gets stuck pointing in a strange direction, causing you to meet a horrible death during a potential world-beating

## LAW OF THE GUN

Jim Douglas checks out two of the new-style pistol grip joysticks and chooses the top gun

attempt at Billy and The Springy Things.

Phasor One loses major cool points owing to the completely ghastly logo on the stick. Apart from that, it's pretty sound.

Phasor One is available through Britannia Software and costs £12.95

**T**he Magnum, from Mastertronic is a designer joystick if ever there was one.

A black body, blue top and red shaft and fire button make it probably the least unpleasant looking joystick around.

Literally, magnum means 'big'. A fairly apt description. This is the most bulky joystick we've seen recently. Its fire-button is located towards the back and on a sloped bit and is designed to be thumb-driven.

The shaft can be located at the very top of the blue platform, and makes a very satisfying "click".

The main problem with the Magnum is that you'd expect to be able to slam away at it with gay abandon. The trouble is the grip is so big that you can't get a strong enough grip to be able to exert any force.

Magnum costs £12.50

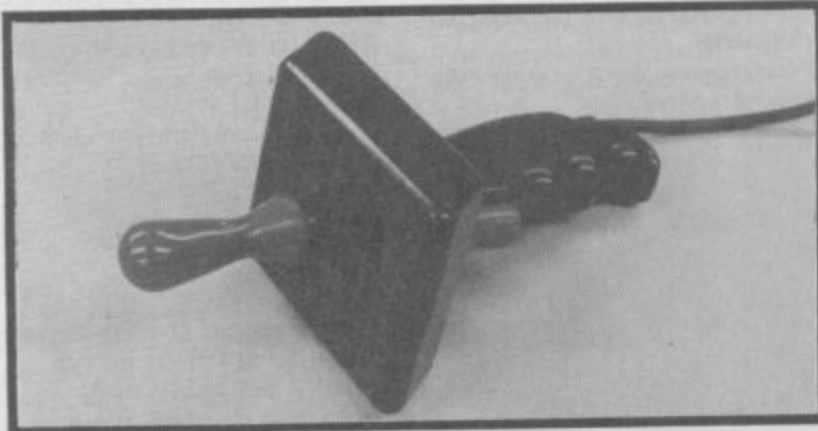
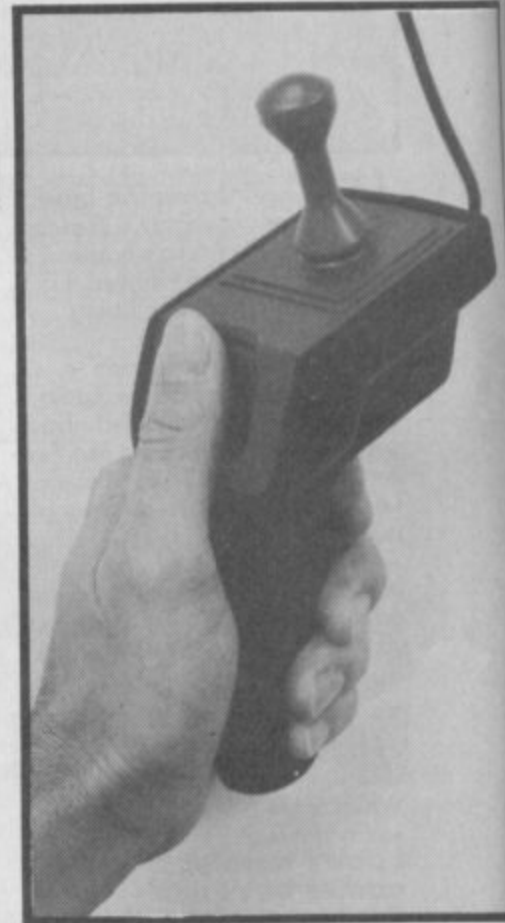

Looks: 8/10 (Nice, but naff logo)  
 Strength: 9/10 (Very tough. Maybe the stick would weaken?)  
 Feel: 8/10 (Loses one point for being a tad too small, and another for having a dodgy shaft)  
 Value: 8/10  
 Overall: 9/10

Looks: 9.5/10 (Great, but not quite perfect)  
 Strength: 7/10 (Looks mega-strong, but isn't really)  
 Feel: 8/10 (Feels a bit plasticky, but is also quite nicely weighted)  
 Value: 8/10  
 Overall: 7/10

## BARRY PAUL

67-69 Leather Lane, London, EC1 7TS  
 Tel: 01-405 1515/6078/1270

Full range of records, cassettes, CD's & video's in stock

Visit Our Shop Mon to Fri 9.30-5.30

PSI S Trading Company	5.50	Colour of Magic	6.50	Thanatos	6.50
Leaderboard	5.99	Jail Break	5.50	Fat Worm	6.50
Fire Lord	5.99	Graphic Adventure Creator	22.95	Big Four Durrell	6.50
Footballer of the Year	5.50	Tarzan	5.99	Druid	5.50
Future Knight	5.50	Theatre Europe	6.50	Scooby Doo	5.50
Trail Blazer	5.50	Annals of Rome	6.50	Space Harrier	5.50
Terra Cresta	5.50	Scrabble	3.99	Mag Max	5.50
Great Escape	5.50	Chess	1.99	Star Glider	9.99
Armour of Antriad	5.99	Monopoly	6.50	Ikari Warriors	5.50
Xeno	5.99	Pawn	9.99	Gauntlet	5.99
Uridium	5.99	Cosmic Shock Absorber	5.99	East Enders	6.50
Judge Dredd	5.99	Paper Boy	5.50	Cobra	5.50
City Slicker	5.99	Elite	9.50	Cluedo	6.50
Shadow Skimmer	5.50	Light Force	6.50	Scaletic	6.50
Orbix	5.50	Cyborg	5.50	Eidolon	6.50
Trivial Pursuit	9.99	Dandy	5.50	Artist II	8.50
Any Mastertronic	1.75	Explorer	5.50	Dracula	6.50
Camelot Warriors	5.99	They Stole a Million	5.99	Torbruk	6.50
Avenger	6.50	Yie Ar Kung Fu II	5.50	5 Star Games	6.50
Sky Runner	6.50	Konamis Golf	5.50	10 Computer Hits 1 + 2 or 3	6.50
Double Take	5.50	Dark Sceptre	6.50	Crash Smashes 1 + 2 or 3	5.99
Aliens	6.50	Bazooka Bill	5.99	Archers	6.50
1942	5.50	Xevious	5.99	Tempest	5.50
Mailstrom	5.50	Bobby Bearing	5.50	Donkey Kong	5.50
Top Gun	5.50	Shao Lins Road	5.50	Legend of Kage	5.50
Hard Ball	5.99	Konamis Coin Op Hits	6.50	Ram Turbo Interface Dual Port	13.99
Fairlight II	6.50	Gallipoli	5.99	D K Tronics Dual Port Interface	8.99
Kayleth	5.99	Nemesis	6.50	QS II Plus (Micro Switched)	11.99
Scaletrix	6.50	Breakthru	5.99	Comp PR 05000 Joystick	13.95
Supa Soccer	5.50	Kat Trap	5.99	Cheetah Mach 1	13.95
				Konix Speed King	11.99

Make cheques/PO payable to Barry Paul. Allow 28 days for delivery. Please phone for details of new releases and any games not listed.

# write stuff...

## Pippo Mastertronic

Why didn't you ever review this gem from Mastertronic? It's great. Pippo is really Q-Bert in another guise. Nevertheless it is very addictive and the pseudo-3D graphics are excellent. The introductory graphics are brilliant, although somebody should point out that not everyone has five-letter names



**Darren Walshe**  
Basildon  
Essex  
Game choice:  
1942

## The Great Escape Ocean

I agree with you totally, Ocean's The Great Escape which my friend's got is wonderful. It's just like the film and the plot is short and simple which gives the game a feeling of class. Graphics are brill and there are no colour clashes. Some of the ideas in the game are incredibly original: who would think of using medals for a scoreboard and a flag to show your strength?

Recently Ocean has got itself a bad name with some poor games but after The Great Escape I knew I shouldn't have doubted them

**Matt Tomlin**  
Battle,  
Sussex  
Game choice:  
The Great Escape

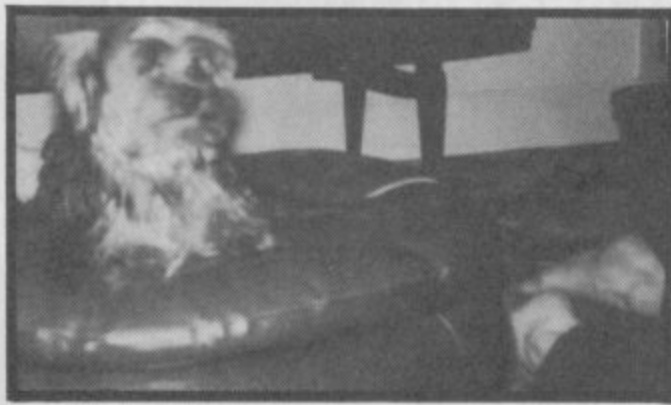

## Pub Games Alligata

How can you give Pub Games a 4-star rating? Graham Taylor must have had about thirteen pints before reviewing this. It's the most useless piece of software around.

There is only one decent bit - the darts - and that isn't a patch on Mastertronic's 180 which is more exciting and quite funny too.

The rest of Pub Games is

trash and seems to have been written hundreds of years ago.

As you can gather, I hated the game and for people who are thinking of buying it, save your money as you'll get cheezed off straight away

**Richard Beattie**  
Barrow-in-Furness  
Game choice:  
Space Harrier

## Dan Dare Virgin

You were right Dan Dare - it's BRILL!

It has the best backgrounds of any game I have ever seen. So much colour which refuses even to quiver when Dan screams past in his lush green uniform. Dan is brilliantly animated, too. Go out and get it

**Graham Quinn**  
Durham  
Game choice:  
Space Harrier



## Strike Force Cobra Piranha

Mixed views for Strike Force Cobra. Be prepared for a challenge, though. And it certainly isn't as good as you said it was.

Strike Force Cobra requires much thought and fast reactions. Choose an

elite force of four Cobra's from a choice of eight. Each Cobra has different abilities and you've got to choose the correct team. After this you must begin your attack. Here's the catch. The time you have before you fail the mission is limited.

You must rescue all of the scientists in order to get the code to destroy the main computer. The labyrinth is on four levels with well over 250 screens to overcome. Some rooms have robots or human guards and some even have guns firing bombs.

Overall, though, I found the game quite annoying although the graphics are first class. The use of colour is good but the sound can make the atmosphere very annoying

**Matthew Phillips**  
Herts  
Game choice:  
Aliens



IF you reckon we're talking rubbish don't just stand there...

Tell us what you think.

Stick your comments on paper, fill in and cut out the coupon below and send it in...

And if you don't send us your picture - the sillier the better - we'll have to print a picture of a slug

## Virgin Atlantic Challenge Virgin

Virgin Atlantic Challenger is made by your review in October's SU to look boring and unplayable.

It's nothing of the sort. I found dodging the icebergs and fishing boats megabril.

Making dear little Richard Branson eat, drink and repair various parts of the ship was great. And as for your quote it should be a budget game, that's a load



of cobblers. At £7.95 the game's a steal

**Matty Everett**  
S Yorks  
Game choice  
Super Soccer

## Knight Rider Ocean

For once I agree entirely with one of your reviews. After waiting a year for the game I expected a lot better. It's shocking. The graphics are appalling on the driving



screen and the scrolling is useless.

The plot is very unoriginal - stop WWII getting started. How many times have we heard that before?

Detail on the dashboard isn't what I'd call good and, given the time Ocean spent developing the game, it should have been better. Whatever you do don't buy it

**James Baldock**  
Waterbeach  
Game choice:  
Avenger

Every so often - well very often actually - you write to tell us that we know nothing about anything and insist that some program we trashed is actually the best game ever. Conversely you blast us for saying something is great that you absolutely loath and detest.

Enough is enough. We can't take any more, if you think you're so clever you write the damn magazine. We mean it! Every month we'll devote a page to a selection of your opinions on the latest software. Don't get mad write the review you think the game should have received and we (subject only to space) will print it.

Now, aside from seeing your work in print we will send you a crisp £10 - er, cheque - with which to buy the software title of your choice - tell us what you plan to spend the money on if your review is printed.

One request, we want to know what you look like so send us a picture. Any old picture will do - you at home, in Ibiza, in the garden, even making silly faces in photobooths we don't care.

So get cracking - write your reviews and send them together with the completed coupon below.

### YOUR REVIEWS

Maximum 150 words. No swearing, libel or illegibility and come out of the corner fithing. Don't beat around the bush - tell us straight what you think. Send your review (or any recent game) plus your picture and fill in the coupon. \* send the lot to The Write Stuff, Sinclair User, 30-32 Farringdon Lane, London EC1R 3AU.

Name .....

Address .....

The program I would most like to buy with my tenner is .....

\* Reviews supplied without full name and address will not be considered for publication.

# COMPETITION WINNERS

Spot the Editor Compo!

**L**ife, eh, readers? What's it all about? Just when you think that you have tailored your image to suit the career of your choice, lots of people write to a well known magazine and destroy your illusions.

David Thing (who?), Editor of this fine organ found himself in a similar position when judging the Spot the Editor competition. Finding the results completely unbelievable, he made all sorts of charts and diagrams, trying to warp the statistics, BUT THE FIGURES DO NOT LIE!!

- 35% of the entrants decided ThE mAD CeIT (A) was the editor.
- 34% Chose the be-suited Graham (F) as their ideal Ed
- 22% Thought John (C) looked the sort of crazy guy to edit **SU**
- A paltry 6.5% guessed correctly that the guy in the horns was David, The Ed. (E)
- 1.5% Plumped for Clare (D) (who's not even on the mag any more)
- 1% Voted for Louise (in the Bowler) (B) and finally...
- Linda and Alison, (G) and (H) 'failed to score.'

The winners – who collect image-building Design Design T-shirts – are: S Rawson from Barnsley, Richard Payne from Middlesborough, T Rowlands from Suffolk, Ian Andrews of Eastleigh, Paul Dais of Briston, Khalid Sohail from Saudi-Arabia, Marcus East from London, Nicholas Patrick from Oxfordshire, Nick Bartlett from Cornwall, Sheldon Smith of Lowestoft and Neil Williamson of Wakefield. Well done!



The people's champion ...



... And looking very dodgy



The whole rabble

# ARE YOU FOOTBALL CRAZY



## FIND THE FUN IN FOOTBALL with your up-to-date football weekly

Every week – Match Facts, the top results service including star ratings for every player. Fun to enter competitions to test your football knowledge. Big match reports. Super colour pictures. Up to date news and views.

**DON'T MISS YOUR FREE F.A. CUP  
DIARY – with the 10 JAN ISSUE!**



**ORDER YOUR COPY NOW!**

To my newsagent: Please deliver/reserve MATCH every week.  
Price 45p until further notice.

Name .....

Address .....

Postcode .....





# NOTE PERFECT? **SU** wonders how many elephants you can get in Cheetah's new MIDI

Cheetah busted a few price barriers with the SpecDrum and marginally missed the boat with its sampler (because of the Ram Music Machine).

Now here's the MK5 music keyboard which puts them right back on top of the price-busting music technology ladder.

A point to stress, the keyboard has been developed for Boots and if this review inspires you it's there that you should run, Cheetah itself doesn't sell them.

Why is the MK5 one of the best value electro-musical tools ever? On its own it does nothing except wink a few lights and sit there stupidly. It has no sound creation facility whatsoever. You can press its keys as much as you like but it won't make a single noise (other than a vague click).

In that sense it isn't for absolute beginners - you need to couple it with something else first. Either a 128K or 128K+2 Spectrum and Cheetah's own Midi interface.

This useful little device used the Midi Out socket on the back of the keyboard to connect to your 128K Spectrum. You load some driving software and *voilà* - you can play three-channel sound using the Spectrum sound chip on the MK5.

The software also allows you to edit your own sounds but mostly they are going to sound like bleep, blop, nahp beeeeeeeep. Nevertheless, being able to play the sounds on a full (five-octave) keyboard is a revelation.

Even better is the Pitch Bend wheel - you can connect this device up to the Spectrum and, gasp, bend them weewwwwwwwww (become a sincere Jan Hammer/Stevie Wonder type Jazz musician and do great solos).

The Midi Interface has some

other nice features: mixing tones and noise and dividing two sounds over two halves of the keyboard.

It could have more features than it does - sequencing, screen composing and so on - but that's really to criticise it for what it isn't and Cheetah is promising to produce all those sorts of music composing tools as add-on software for the system.

Using the MK5 with a Spectrum and Midi is really only the thin end of the wedge as far as what it can do is concerned. As a five-octave Midi compatible keyboard with large keys it's ideal for being connected to other synthesisers and computers.

For £99.95 (that's a hundred quid in real money) it's just about the cheapest 'slave' keyboard around. You could, for example, hook it up to a wonderful Casio CZ101 synthesiser which has very small keys to get a powerful synthesiser with big keys and five octaves.

The keyboard also has a program function. This enables you to change the octave range and to send instructions to other music instruments. For example you can, from the MK5 keyboard, send messages to your Casio CZ101 to change the

current sound selected. Having this sort of Midi-based control from a dummy keyboard is a sophisticated feature usually associated with keyboards costing £400 or more.

Ultimately you could end up with a system consisting of the MK5, Casio CZ101, Spectrum, Cheetah Midi Interface or Ram Music Machine and maybe some Cheetah driving system

Fairly basic software ● But straightforward to use ● Put the MK5 with Ram's Music Machine and maybe a CZ101 and you're talking serious sounds

software like an on-screen composing program.

In fact, Ram Music Machine, MK5 and Spectrum would give you a sampling keyboard, with some music editing facilities as well as a drum machine. That's serious musical power.

The keyboard itself? It's nicely made of plastic and metal, with a playing action about as good as you'd expect below £500. The Pitch Wheel is located oddly at the back of the keyboard, around one octave up. In fact this proves to be quite a sensible playing position but posing-wise isn't as good as the 'I'm deeply emotional' far left alongside the

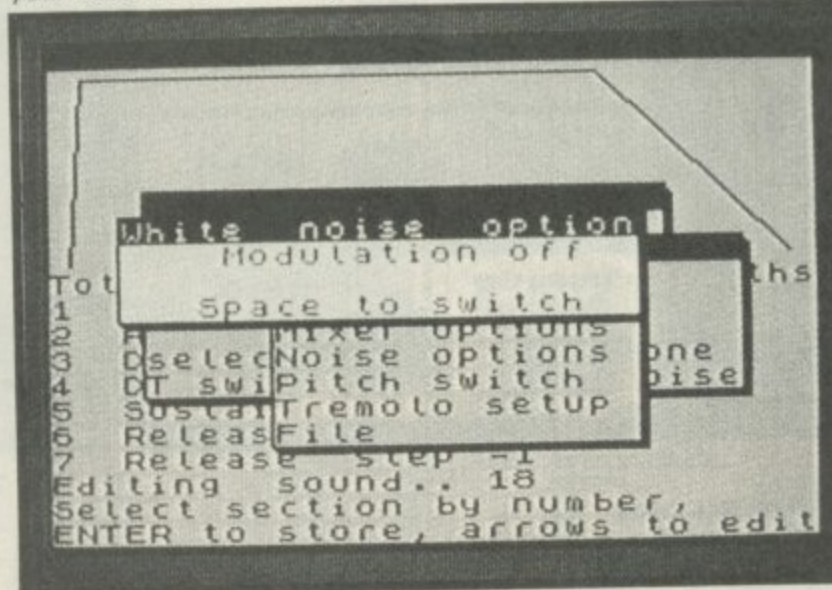
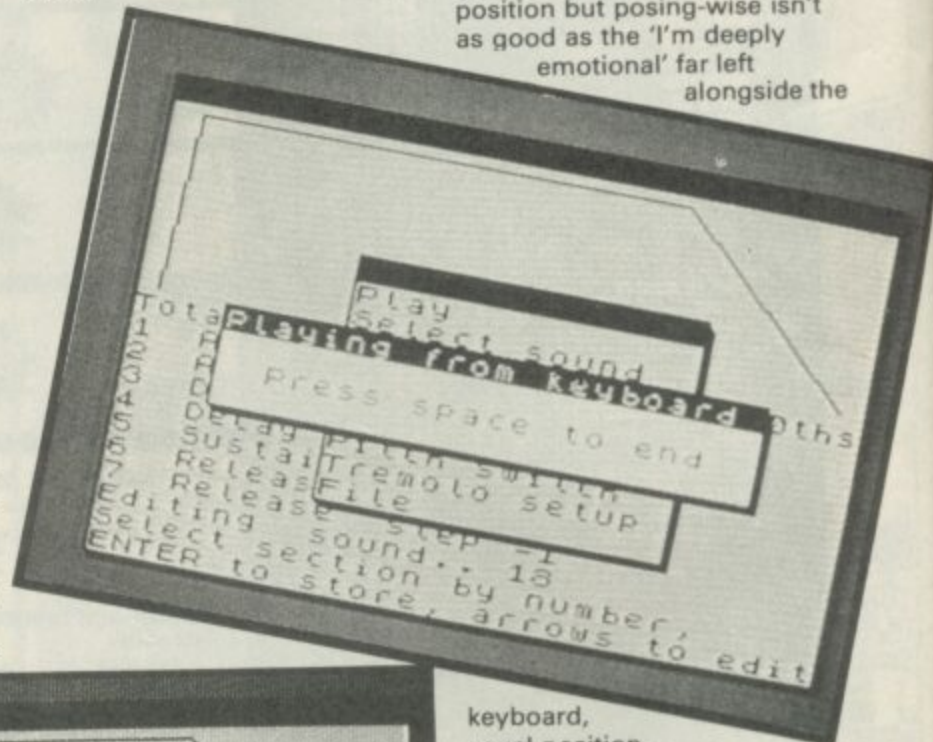

keyboard, usual position.

The program select feature is economically done, where a single button moves into programming mode and the top few keys then act as switches. A large LED shows the current state of Midi channels or program locations. There are 128 programs which is enough for most Midi keyboards.

In short it's a very appealing package. If you are just getting into mixing computers and synthesisers then the MK5 and Midi Interface is a good first step (especially with a Ram Music Machine). A winner



# SHAO-LIN'S ROAD

ARCADE



REVIEW

**S**hao-lin's Road despite being a popular arcade game is not necessarily a cash-raking micro title. There are so many kicky-kicky games around that The Edge has definitely taken a risk in trying it one more time.

Fortunately for The Edge, Shao-lin's Road is a good conversion of the original game. Maybe even a very good conversion. The virtues of the game are precisely those lacking in most of the other, recent, releases – ie big sprites with lots of detail. Careful use of areas of two-colour also avoids much by way of attribute clash.

Actually playing the game reveals that actually Shao-lin's Road may look like some kind of multi-level Exploding Fist but it really isn't. There is essentially only one martial arts attack move here – kicking. Although there is a wild rather slavish leap, your man can perform it only as a defensive move.

Shao-lin's Road is far more about dodging around, keeping out of the way, and kicking the occasional object or person when the time is right. The reasons it's fun to play are really only the usual arcade ones: knowing when to run away and leap out of it, knowing when to attack, when to go for the bonuses. You won't have to spend ages staring at a chart of joystick moves in this game!

Each level consists of a team of enemy warriors most of whom can be dispensed with fairly easily and one leader who usually takes more than one kick and also follows you about. The screen is presented in three layers – you can jump between them but the warriors seem to

use the lift. When they are getting out of the lift is a good time to indulgence in a little face kicking. The real art of the game, however is to use the

bonuses – objects which fly across the screen for extra points. One looks like a bomb, the other appears to be a deadly pizza (probably Hot Chilli, I imagine). Better is the sparkly thing that appears. Grab this and you get, temporarily, a

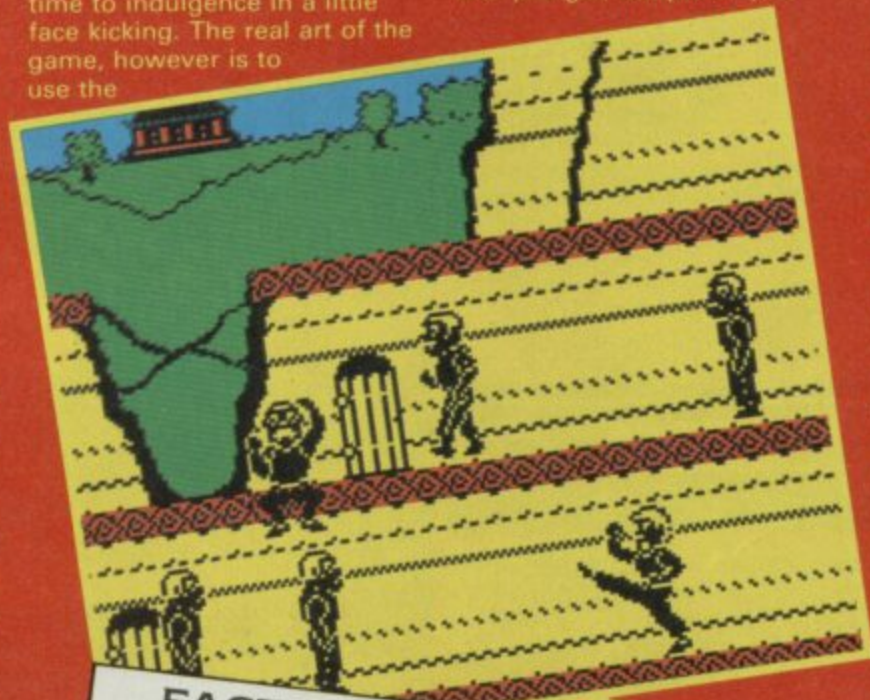

## FACTS BOX

*A fine conversion. Should do well even though the martial arts thing has been covered pretty well by now*



SHAO-LIN'S ROAD



Label: The Edge  
Author: in-house



Price: £7.95



Memory: 48K/128K



Joystick: various



Reviewer:

*Graham Taylor*

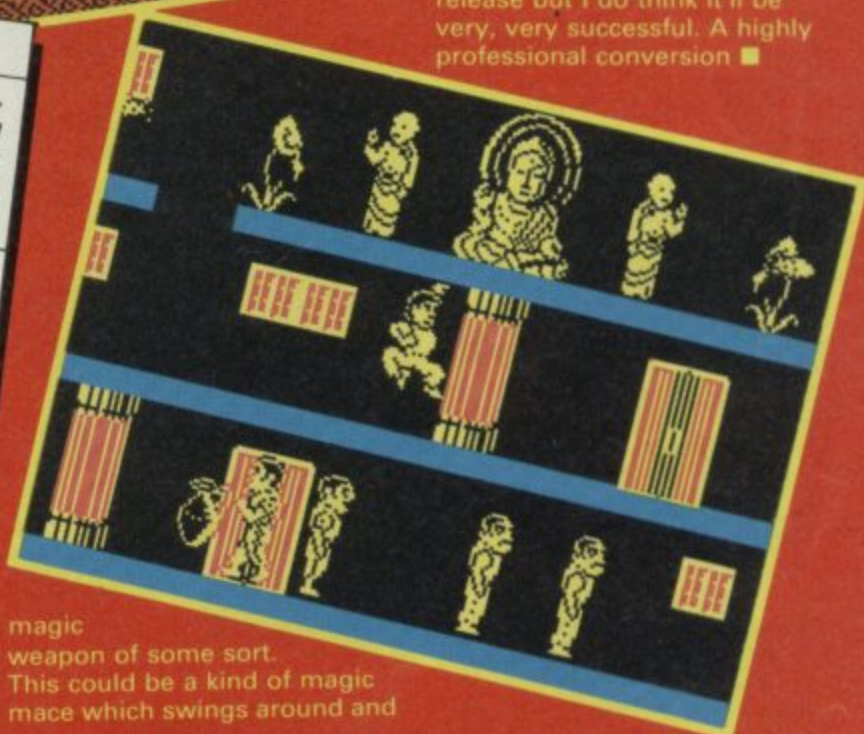

magic weapon of some sort. This could be a kind of magic mace which swings around and

## SOFTWARE STAR RATINGS

All software reviews carry a star rating, the basis of which is value for money programming, graphics, speed, speech and sound presentation and addictiveness

★★★★★

Solid gold. Buy it

★★★★☆

Well worth the folding stuff

★★★☆☆

Pretty average

★★☆☆☆

Very poor. Probably over-priced too

★☆☆☆☆

A total rip-off. Complain loudly



Each review carries an icon which shows the type of software.

Arcade is for animated games, which in general, reduce the life span of your joysticks.

Toolkit covers programming utilities which improve the quality of home-made software or packages which make machine code easier to write.

Work Out, software which can be used in the home, such as car maintenance or home finance.

Strategy and Simulation are games where thought, planning and judgement are the principle skills required.

Adventure includes either graphic or text adventures.

# ALIENS

SINCLAIR USER  
CLASSIC

Five marines, the ex-Flight Officer of a doomed space freighter, and a little girl called Newt are trapped in the colony base of a lonely, distant planet. And all the colonists are dead, gutted by the face-hugging parasites which use human bodies as disposable wombs.

This is *Aliens* the movie and now *Allens* the game.

The base comprises a massive 248 rooms and corridors, you've got no idea where you are, and only six very vulnerable characters to control - Riply, the Flight Officer, heads the cast and Lieutenant Gorman commands the marine team of Hicks, Burke, Vasquez, and the Android Bishop.

You control the whole thing from a console which shows the strengths of all the characters' their firepower and heart rate and the view through one of the video cameras worn on the helmets of each character. So you get kind of player's eye point-of-view of the base - and you can switch between your characters looking, as it were through their eyes.

So there you are with your

team standing at the entrance to the base. Wait long enough and the aliens will come for you rather than the other way around. Better do something.

Choose one of the characters to move - you can only control one at a time. Push the joystick forward to go forward, left or right to turn. And the character's eye-view scrolls accordingly.

At first the base seems incredibly complex and it's difficult to work out where you're going let alone how to find your way back.

And just when you think you're going really well you hear the warning alarm sound. There's an alien in the room with you! As the creature comes closer the warning pitch rises and you begin to fear. Where is it? - you can't find it. You whirl round but suddenly the screen blanks out in a flurry of static and you've lost one of your team. Without even getting a glimpse of the creature or a chance of a shot. This is more difficult than I'd expected.

It wasn't long before I'd wiped out my whole team! My second attempt was better though.

The gameplay is unusual - you may think it's odd but I thought it was very effective. Basically you can play the game how you want. It is a strategy game. Or is it an arcade shoot 'em up.

It's up to you. You can zap around trying to knock off as many aliens as you can - periods of relative boredom punctuated by short bouts of nerve jangling frenzy. Shoot the aliens and zap the bio-material they create from the walls of the base as you go.



Or you can map and plan your strategy. Keep your team together and try to reach the Queen alien's chamber and destroy her.

When you switch between characters, using a key letter, the display changes with a quick sparkle of interference. All of your team have a gun so things aren't as tough as they might have been. The big problem is lining up your sights on the alien before it gets you. When it all happens it all happens very fast.

You use the smart guns for destroying aliens, face huggers, generative gooey-stuff, and any of your buddies who have been impregnated.

There are two ways in which you move around the base. Obviously by joystick. Find a door and press the Spectrum's space bar to get into the next room. Some doors are locked and you'll have to blast through them to continue.

Rooms are made up of several screens. You don't have to scan them all unless there's an alien in the vicinity. When the warning sounds scan the room with the joystick and when you catch up with its shuffling, hump-backed, body aim at its head and fire. One

shot to the head will finish it but if you hit only the body you'll need three blasts.

If you aren't quick enough the claxon builds to a scream, the alien turns and it's two pairs of jaws open to bite deep into foam, plastic, flesh and bone. I defy any player to get used to what are some of the most realistic graphic effects I've ever seen on the Spectrum.

## HINTS AND TIPS

- Make a map. Hardly a revelation, but until you map it out you won't be able to move your team automatically
- Doors may be locked for a purpose. Blow the wrong door and you could be chomped
- Avoid alien blood. If it blocks doorways don't go through them or you could boil like the acid it contains
- The alien catacomb structures on the walls are used to store human bodies. Destroy them and gain points
- Don't go out alone. You never know what's lurking in the next room. Move your forces as a team and stick together
- Don't try to leave the base. You won't survive more than three seconds on the planet's surface

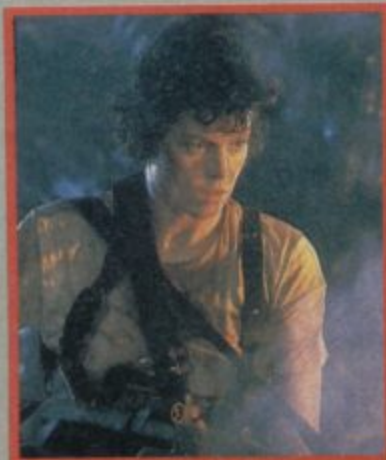



## FACTS BOX

*A blockbusting arcade/strategy experience. You'll not be disappointed, the tension is something you really feel*

### ALIENS

Label: Electric Dreams  
Author: Soft Machine  
Price: £9.99  
Memory: 48K/128K  
Joystick: various

Reviewer: *John Galbraith*



You'll see even better graphics if you wait until the creature turns and gets close before firing. Its head explodes in a cloud of large, black, fragments.

You can only move one room at a time using a joystick but there is another method, by which you can move through six or seven locations at a time. When you've mapped the game fairly thoroughly you can type in the number of locations you want to move and the direction in which you want to walk. For instance 2E would take the viewpoint character two locations East without having to worry about which door in the current room leads where.

Aliens don't always kill. One of your team could be captured and prepared for impregnation. If that happens his - or her - strength bar turns yellow and you should send another team member to save that character. If the bar reaches the right side of the status window the impregnation is complete the character should be killed before the baby alien leaps from the stomach.

All this killing depletes laser power so the first destination for all the marines should be the armoury. The walls of this room are laden with guns and bombs but you don't have to pick them up. Any character who enters the room will get an increased ammo status.

Once you've been to the armoury you can visit some of the other incidental rooms. There's the Generator Room which you must keep free of growths or the base's power will fail and the Control room which you must also rid of growths or the lighting will fail. After you've visited all these

rooms you can progress through the maze towards the queen's chamber where face huggers go into action and the whole alien operation is controlled. Once you've entered the chamber you must activate the base's biomech device to cause the aliens to decompose. Unlike the film there is more than one alien queen and you'll have little time to activate the device with face huggers, alien warriors and queens loping and lurching after you.

Survival is difficult - to say the least - in *Aliens*. The best plan, though not always successful, is to move the whole group from one location to another. One character should scout ahead and if there's trouble you can destroy the troublemaker easily. I've lost a few like that, but I have also managed to explore most of the base.

Electric Dream's latest baby may be a licensing deal but there's no stigma attached to this one. It's a game of realistic graphics, limited arcade action and sophisticated strategy. The simple storyline makes for software magic.

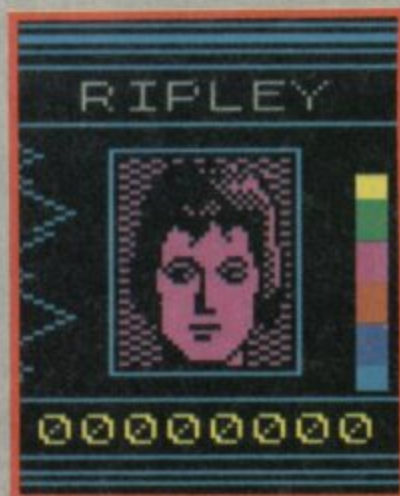

**S**tar Wars, America's wholly unsound Strategic Defence Initiative, is the subject of Quicksilva's new game.

No danger of pussy-footing around the subject here, I can tell you. Everything goes wrong right from the beginning. Instead of the commies being behind an evil plot, however, it's the oldest standby of the lot - the mysterious alien horde.

While the satellites go about their entirely peaceful business (yet they're choc-full of really big lasers), a huge green-headed boggly-eyed fungus monster creeps up on them and points the damned things toward various important places on Earth, and starts destroying cities.

Taking control of a spaceship, you fly over the Earth's surface, darting back and forth in order to save cities from destruction.

The screen is presented in rather impressive 3D, showing the world's rotation beneath you, and all the horrible little beastly aliens zooming around. The aliens look a bit like throat lozenges with water-wings, but they're quite impressive, all the

## ARCADE



## REVIEW

### FACTS BOX

*Defcom is a moderately addictive shoot-out with a tiny bit of strategy thrown in for good measure. Great music*

### DEFCOM

Label: Quicksilva  
Price: £7.95  
Joystick: various  
Memory: 48K/128K

Reviewer: *Jim Douglas*



# DEFCOM

same.

Your space-craft is viewed from behind, and moves around in a rather uncomfortable arc, a-shootin' and a-firin' for all it's worth.

And the music - like that on Quicksilva's other recent release, *Glider Rider* - is very good indeed. Very, um, 'spacey'.

Now, things would get purrrretty ruddy hairy if you had to dart over the planet without some form of assistance. Thankfully, a mappy thing can be dragged on to the screen indicating the locations of yourself, and the satellites.

When the message 'Gor! Luvva duck. Tokyo is having a bit of gip.' (or something) pops up, you can flick to the map, and work your way to Tokyo. The only problem is that, as it takes

such an astounding amount of time to reach your destination, the aliens will have already moved on.

*Defcom* is 'classic' shoot-out with a few inventive touches and a completely wasted 'political' novelty angle. The 3D is nice but too superficial, though, to maintain one's interest.



# HYPABALL



*Calin*  
COMPUTER GRAPHICS LTD



SALES 01-631 5206  
01-379 6755  
INTERNATIONAL 44-1-379 6755  
COMMODORE 64/128: SPECTRUM 48/128K

**C**RL's Dracula is a masses-of-hard-to-read text adventure with some graphics, which owes its reputation largely to the 15 Certificate plonked on it by the British Board of Film censors.

Being the only horror officianado on **SU** I was intrigued to know what the censors found so appalling. I was, however, soon to learn that the 15 suits the content of a game which at times puts up goulishly digitised pictures of death and atmospheric descriptive passage – some of which could have been pulled straight from a Shaun – see last month's fantasy page – Hutson book.

The game is in three parts, all of which can be played independently, and it reads very like a book. There's three complete game Loads here so it's big. The first part, called The First Night, takes place at the Transylvanian inn where Jonathan Harker spent his last night before his trip to Count Dracula's castle. It's designed as a gentle introduction to new adventurers and as a scene setter for more advanced players. All you need to do is pay the coachman, sign the inn's register, pick up your keys and have dinner to regain your strength. After that it's up to your room for some sleep. Do go up to bed. There's a nifty dream sequence with gore plenty for horror fans. Make sure that you close the window or the nightmarish visitation which you see as a dream image will chase you into reality and kill you.

If you die in Part 1 you're treated to one of the digitised death pictures, in this case a cowled skull, neatly illustrated in red and blue.

The Arrival, the second part, is a different story altogether. You'll find it fiendishly difficult to escape from the coach which takes you most of the way to

# DRACULA

```

HER FACE IS BARELY VISIBLE..
THE COACH RUMBLES ON...
I'M READY FOR YOUR INSTRUCTIONS.
LOOK INTO EYES
I LOOK AT THOSE DARK EYES..THEY
SEEM TO BRIGHTEN,WHILE ALL
AROUND GROWS DIM....I NO LONGER
SEE THE COACH,OR HER FACE!
  
```

```

IN THOSE DEEP POOLS I SEE IMAGES
YET TO COME!..A DARK ROOM....
I SEE THREE PEOPLE IN WHITE
SHROUDS,CLAMOURING OVER A BED IN
THE CORNER.....THEY ARE YOUNG
WOMEN WHO GIGGLE INTERMITTENTLY
..NOT THE LAUGHTER OF INNOCENT
YOUTH,BUT OF SOMETHING MUCH MORE
SINISTER...THERE IS SOMEONE IN
THE BED..I HEAR NOISES...THERE
MUST BE A DOG HERE..YES A DOG,
CHEWING A PIECE OF MEAT?
  
```

PRESS ANY KEY TO CONTINUE

## ADVENTURE



## REVIEW

Castle Dracula. A very strange and shady lady occupies the carriage with you and, if you stare at her long enough she'll give you some indication of the future – particularly of three ladies who are very long in the teeth. If you're lucky you'll escape from the Castle with only your sanity out of gear, get back home to England and be able to prepare for Part 3: The Hunt.

I managed to solve The First Night in 20 minutes, which did not bode well for the rest of the game. The language parser takes only the first few words of each command into account, so you can't string several commands together as it'll only obey the first one. In some cases, however, the language is necessarily dense. For instance, when you type *Look* you'll get the reply 'I see nothing of consequence'. You've got to specify the object of your desires and in some cases – particularly in Parts 2 and 3.

So far you've mainly taken the role of Johnathan Harker, who's devil's own task is to deliver the deeds of Carrfax Hall into the hands of the Count. He moves into the Hall, near Whitby in Yorkshire, and you take on the guise of John Seward, physician and diary keeper. He's a resident of the village in which Dracula stalks at night.

Some places are off limits in this part of the game, until you progress beyond a certain point. For instance, when you leave your house the directions to Carfax Hall are given but, when you try to go there, the program says 'I don't want to do that at this time'.

You'll also have to revisit some locations more than once to pick up objects which you didn't know were there unless you took advantage of the unhelpful *Look* command to see in all the nooks and crannies. For instance, you can visit the village store but can't buy an all important newspaper – unless you've picked up the money at an earlier point.

Despite those admittedly nit-picking criticisms and reservations Dracula is great fun. Some sequences may disturb Mary Whitehouse but I can't see anyone else being affected. There's nothing in the game which is utterly grotesque and there are no stomach-lurching scenes ■

### FACTS BOX

The gothic character set and digitised pictures just make you want to die. Great ghoulish fun in three full Loads

- ★ DRACULA
- ★ Label: CRL
- ★ Price: £9.95
- ★ Author: Rod Pike
- ★ Memory: 48K/128K
- ★ Reviewer: John Gilbert

# SU's Fault Fixing Chart

The worst has happened. Your Spectrum absolutely refuses to load another game or take another line of Basic. It's gone on strike. So what can you do? Take it back to the repair shop? Maybe. There's always the chance that it's something you can fix yourself, and that saves money, time and hassle. What you need is the **SU Fault Fixing Chart**. Even if - shudder - you can't mend your Spectrum without help, at least you'll know what to tell the repair man. More time saved. Who says we don't look after you?

## Before you start...

Most faults just happen, with no apparent cause. But some are the result of an accident or other mishap, and these can be much easier to explain. For example, did a joystick port or other add-on get added-on with the Spectrum turned on? Plugging anything into the edge connector on the back of a Spectrum with volts connected is bad news, and means a trip to the repair man for sure. If the problem's intermittent, like the picture going fuzzy sometimes or the computer occasionally resetting for no very good reason, then likely as not it's a cable fault. See if the mains plug is connected properly, similarly check the TV lead. If the problem only occurs with a certain add-on, or a certain tape, then it's probably not the computer. But it could be! If the add-on or whatever seems OK, then follow the chart by pretending that the problem happened all the time.

Problems can also occur with too many add-ons on at once, or having your Spectrum plugged in near to a freezer or noisy thermostat. Moving your computer usually cures it.

## How to use the chart

It's simple, really. Certainly not as complicated as the map for Fairlight. Start at the top, and follow the line downwards. Do any instructions that you find. If you don't know much about the Spectrum and how to use it, then make sure that you've followed the setting-up bit in your manual. Then use the chart. Ask yourself the questions in the diamond-shaped boxes. If the answer's **YES**, then follow the appropriate line. Similarly, don't be afraid to take **NO** for an answer. If your symptoms don't seem to match those described on the chart, then follow the closest equivalent. Eventually, you'll come to a box with a **CHECK**... instruction in it. Those with a \* by them will need expert help, as there's not much a lone Spectrum owner can do against failed components. Consult our list of repair shops.

## 101 Spectrums...

The chart is for 16K and 48K Spectrums, and Spectrums+s only. If you've got a Spectrum 128 or 128+2, then the circuitry is different. However, apart from the sound which comes at you from the TV, you can pretend that you've got a Spectrum+, and follow the tests accordingly. You've even got a little extra help - reset the computer and hold down the **Break** key, and you get a test pattern to tune in the TV with

## Press on

Where it says check the keyboard connections. This you can do yourself, but be warned that it ruins your guarantee. To do this, remove all the screws from the base of your Spectrum. The top half will lift off, revealing the circuit board, and two white ribbons leading to the keyboard. Don't pull at these when removing the top half - just hold the case open without putting them under any stress. These are the things to check. Firstly, make sure they haven't got any creases or tears in them. If they have, then the keyboard membrane (the bit beneath the keys themselves) will have to be replaced. A shop repair job, I'm afraid. But if they look OK, then make sure that the ends are firmly plugged into the sockets on the circuit board. Do this by holding each ribbon in turn firmly between thumb and first finger, just above the connector, and pressing down towards the board (the connectors are strips of black plastic with small metal fingers inside). If nothing seems to make any difference, then it's probably not the keyboard at fault

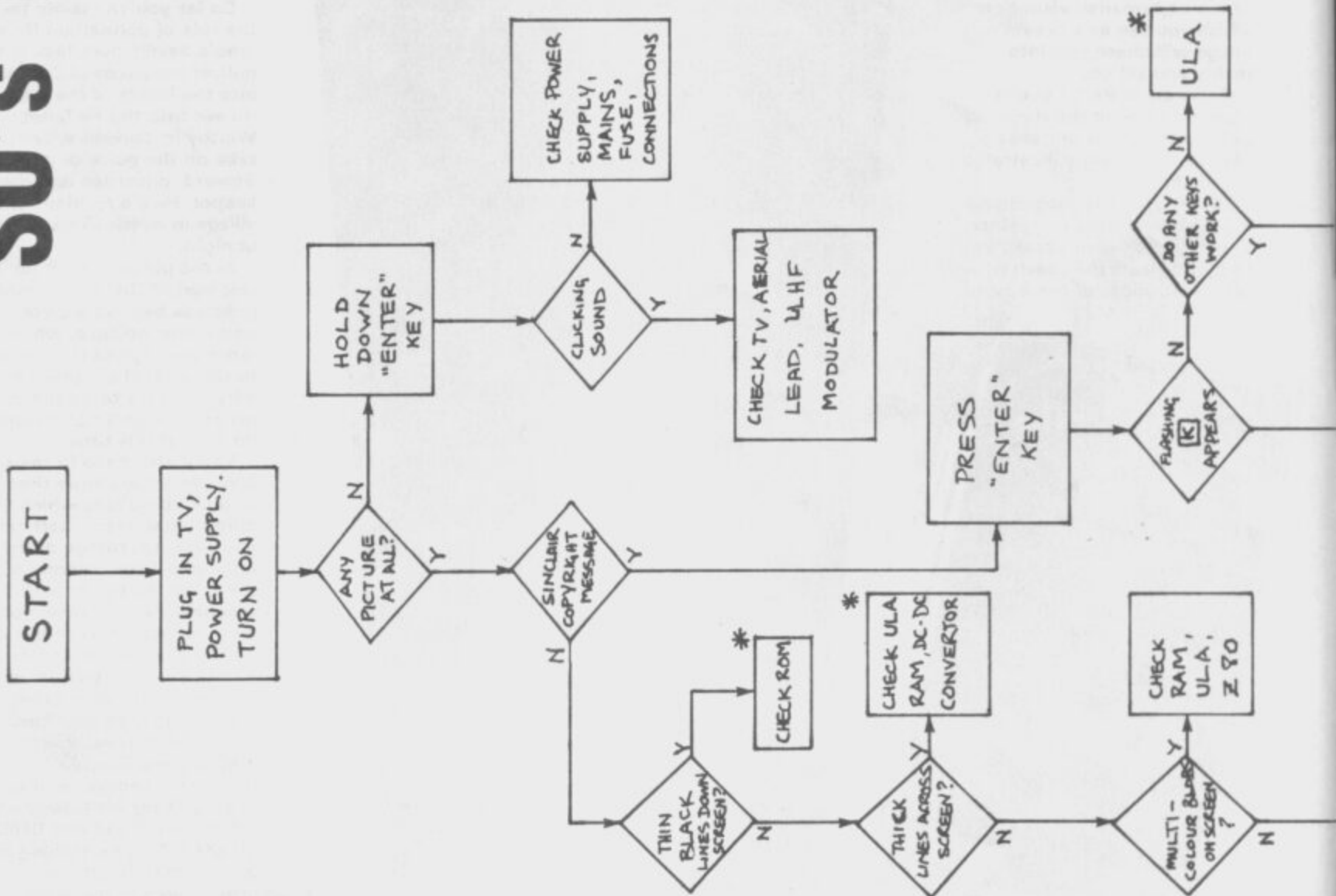

# Repair directory

## EAST ANGLIA

R E Electronics, 133 London Road South, Lowestoft, Suffolk. Tel: 0502/66289  
 Thetford Micros, Unit 4, Leyland Close, Fison Industrial Estate, Thetford, Norfolk. Tel: 0842/65897

Gaztek Computers, 4 Shelthanger Road, Diss, Norfolk, IP22 3EH. Tel: 0379/52327  
 One Step Beyond, 11a Castle Meadow, Norwich NR1 3DE. Tel: 0603/663796  
 M P Electronics, Freeport, Dereham, Norfolk, NR19 2BR

## SOUTH WEST WALES

Technicom Services (South West), Unit 5, Transom House, Victoria Street, Bristol, BS1 6AH. Tel: 093484/3460  
 Capital Computer Services, Unit K2, Cardiff Workshops, Lewis Road, East Moors, Cardiff, CF1 5EG. Tel: 0222/461801  
 IT Western Electronics, Unit G2, Avonside Enterprise Park, Newbroughton Road, Melksham, Wilts. Tel: 02257705017  
 North Devon Micro Centre, Lyton House, Castle Street, Barnstable, North Devon. Tel: 0271/44260  
 Screen Scene, 144 St. George's Road, Cheltenham, Gloucester. GL50 3E2. Tel: 0242/528979

## NORTH WEST

H S Computer Services, Unit 2, The Orchard, Warton, Preston, Lancs. Tel: 0772/6323686  
 Microtrix, 24 Great Moor Street, Bolton, BL1 1NP. Tel: 0204/398176  
 Mancomp, Unit 5, Levenshulme Trading Estate, Printworks Lane, Manchester, M19 3JP. Tel: 061/224 1888

## NORTH EAST

Micro Power, Northwood House, North Street, Leeds, LS7 2AA. Tel: 0532/458800  
 Micro-World Computers, 25 Hill Top Road, Slaithwaite, Huddersfield, HD7 5ES. Tel: 0484/846117

## EAST MIDLANDS

Micro-Mend, Main Street, Farcet, Peterborough, PE7 3DB. Tel: 0733/241718  
 MCE Services, 33 Albert Street, Mansfield, Notts. Tel: 0623/31202  
 Video Vault, 140 High Street West, Glossop, Derbyshire, SL13 8HU. Tel: 0454/66555

Dimension Computers, 27-29 High Street, Leicester, LE1 4FP. Tel: 0533/57479  
 Spectrum Hospital, Centralised Services, Picadilly, Bulwell, Nottingham, NG6 9FN

## SCOTLAND

Bits 'n' Bytes, Block 14, Holden Way, Donisbristle Industrial Estate, by Dunfermline, Fyfe, Scotland, K11 5JW. Tel: 0383/515255  
 Speak/Easy Computers, 141 Mary Street, Motherwell, Strathclyde, ML1 1JP. Tel: 0698/53609  
 Micro Serv, 95 Deerdrykes View, Westfield Industrial Area, Cumbernauld, G68 9HN. Tel: 02367/37110

## WEST MIDLANDS

Quantum, 33 City Arcade, Coventry, Warwickshire, CB1 3HX. Tel: 0203/24632  
 Bull Ring Computers, 1 Waterloo Terrace, Bridgnorth, WV16 4EG. Tel: 07462/66839  
 Micro City, 1a Queen's Road, Nuneaton. Tel: 0203/382049  
 Thomas Walker and Son, 37-41 Bissle Street, Birmingham, B5 7HR. Tel: 021/6224475  
 Specialist Computer Repair Centre, Dept 18, Unit 4, MEB Works, Windsor Road, Enfield, Reddich, B97 6DJ. Tel: 0527/65671

## LONDON/SOUTH EAST

Nobles Computer Repairs, 14-17 Eastern Esplanade, Southend-on-Sea, Essex. Tel: 0702/63377  
 Suredate Computer Services, 45 Wychwood Avenue, Edgware, Middx. Tel: 01/951 0124  
 Prompt Electronics, Unit 4, 15 Springfield Road, Harrow, Middx. HA1 1QF. Tel: 01/863 7166

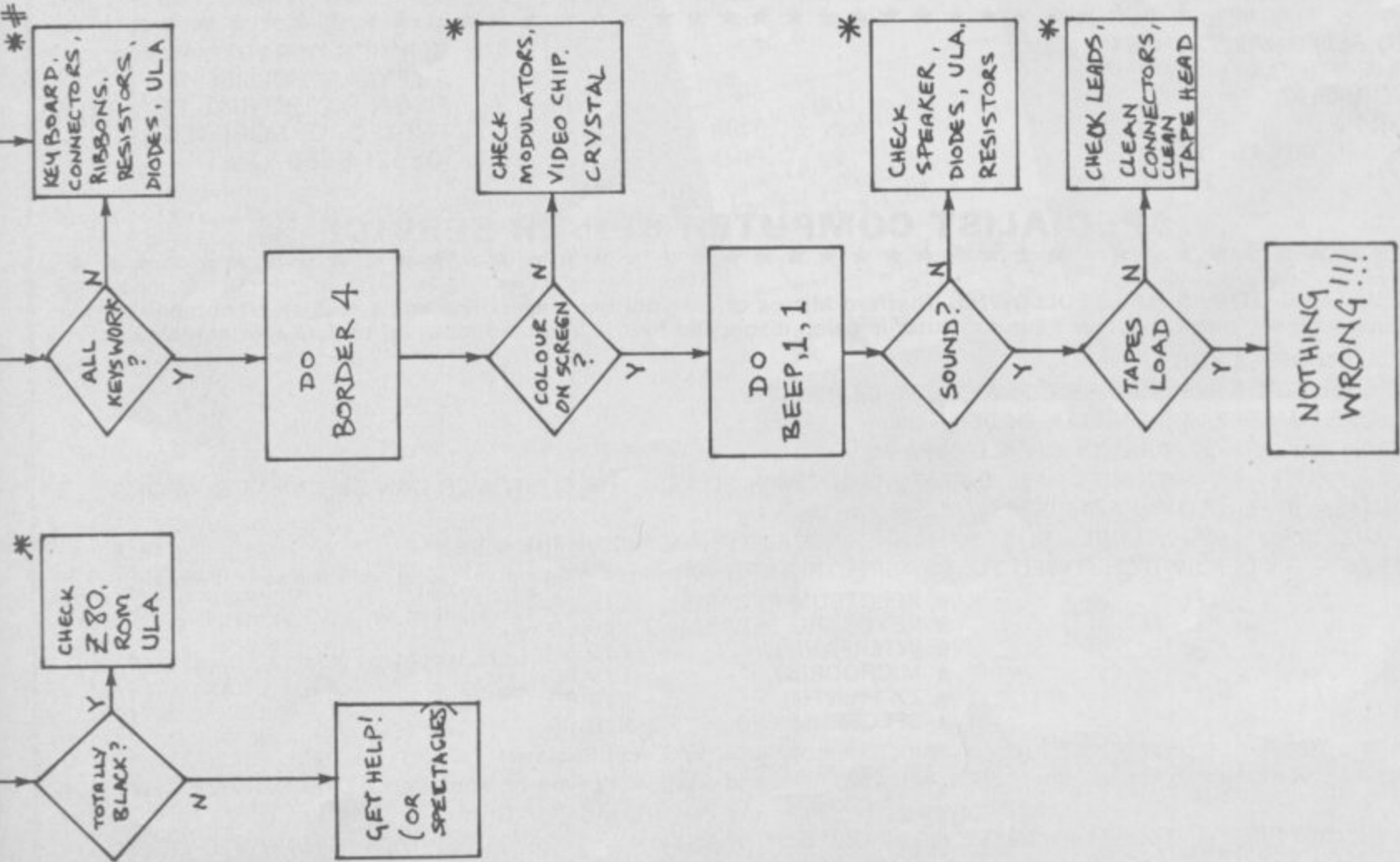

## SCOTLAND: SPECTRUM REPAIRS

Dear Spectrum owner,

This is what we offer you. A six month warranty on all repairs and upgrades. Your computer shall be fully serviced and reliability tested YES, your computer undergoes a full 24 Hr rigorous functional heatsoak test to expose any other potential weak areas. If any weak spots do show up, these are also repaired, and therefore your computer's reliability is further enhanced. ONLY AFTER PASSING THIS TEST DO WE CONSIDER THAT YOUR COMPUTER IS FIT TO RETURN TO YOU

	BITS N' BYTES	
All faults	£19.95	Interface 1 £18.00
Microdrive	£18.00	
<b>UPGRADES</b>		
16k to 48k	£24.95	48k to 48k+ £29.95

Send cheque/PO together with goods to:

**BYTES N' BYTES**

Block 14, Holden Way, Donibristle Ind. Est.

By Dunfermline, Fife, Scotland KY11 5JW

Tel: 0383 824576

## SINCLAIR REPAIRS

Spectrum and spectrum Plus	£14.00
Rubber Keyboard	£ 8.50
Spectrum Plus Keyboard	£12.00
Q.L. Repairs from	£15 - £35.00
Commodore repairs	Price on application
Interface 1, Interface 2 and microdrive repairs	£17.00 each

All prices are fully inclusive of P & P and VAT. Send cheque with computer only unless power supply suspected. Callers welcome between 9am - 1pm and 2pm - 5pm. Monday to Friday

**I.T Western Electronics**

Unit G 2, Avonside Enterprise Park,  
Newbroughton Road, Melksham, Wilts.  
TEL: (0225) 705017

## MICRODRIVE AND INTERFACE OFFERS

Express Service - order by phone.  
January '87 prices include post, packing and  
C.O.D. over £20 in U.K.

### STARTER PACK 1

Microdrive unit, Interface 1 (to connect RS232, network and Microdrives to your Spectrum) plus a demonstration cartridge.  
Delivered for only **£54.50**

### STARTER PACK 2

Two Microdrive units, Interface 1 plus a demonstration cartridge.  
Delivered for only **£77.50**

### EXTENSION PACK

Second (or third or fourth. . .) Microdrive unit(s).  
Delivered for only **£24.50 each**

### CARTRIDGE PACK

Five blank cartridges to get you started..  
Delivered for only **£9.00 each**

*Make cheques payable to Applied Technology.*

Export orders outside Europe: add £4 for Australia and countries bordering Pacific Ocean, elsewhere add £2. Where insured parcel service is not available goods are sent at customers' risk.

**DISCOUNTS** 2 or more packs on 1 order subtract 50p per pack. Postal orders, cash or cheques with order to UK address - over £50 subtract £1 per order, over £100 subtract £2 etc. Please allow 28 days delivery.

AT

**APPLIED TECHNOLOGY**  
64 Tannery Drift  
Royston, Herts SG8 5DE  
(0763) 41754

AT

## T H E T F O R D M I C R O S

21 GUILDHALL STREET,  
THETFORD,  
NORFOLK.  
IP24 2DT  
(0842) 61645

SERVICE DEPARTMENT  
2 LEYLAND CLOSE,  
FISON INDUSTRIAL ESTATE,  
THETFORD, NORFOLK.  
(0842) 65897

## SPECIALIST COMPUTER REPAIR SERVICE

WE'VE LEAD OTHERS HAVE FOLLOWED. Thetford Micros offers you their experience and a fast efficient repair service with our guarantee that your computer is being diagnosed by the best and most up-to-date test equipment.

WE ALSO OFFER YOU:

- ★ ON THE SPOT SPECTRUM & COMMODORE 64 REPAIRS
- ★ SAME DAY REPAIRS ON MAIL ORDER
- ★ THREE MONTH WARRANTY ON ALL REPAIRS
- ★ ALL FAULTY COMPONENTS RETURNED TO CUSTOMER SO YOU THE CUSTOMER CAN SEE WHAT'S WRONG
- ★ ALL ICs REPLACED ON CARRIERS - Makes life easier
- ★ ALL COMPUTERS RETURNED POST PAID AND INSURED IF POSTED IN THE U.K.
- ★ FREE - ON-OFF SWITCH FITTED TO ANY SPECTRUM REPAIR (fitted in Spectrum Casing - Please state if required)

★ SPECTRUM REPAIRS	- £16.00
★ KEYBOARD REPAIRS	- £10.00
★ INTERFACE 1	- £19.50
★ MICRODRIVE	- £19.50
★ ZX PRINTER	- £19.50
★ SPECTRUM 128	- £19.50

(Prices inclusive of Parts, VAT and Postage)

Repairs undertaken on Commodore, BBC, Amstrad, IBM, and Atari - We are an approved **ATARI SERVICE CENTRE**.

Quotes given on repairing any Printers and Disk Drives.

**SORRY NO FREE SOFTWARE - YOU'VE PROBABLY GOT IT ANYWAY!** - ON-OFF SWITCH IS HANDY THOUGH.

For fast delivery service - Securicor £6.90

Payments can be made by Cheque, Postal Order, Barclaycard, Access or American Express.

# COBRA

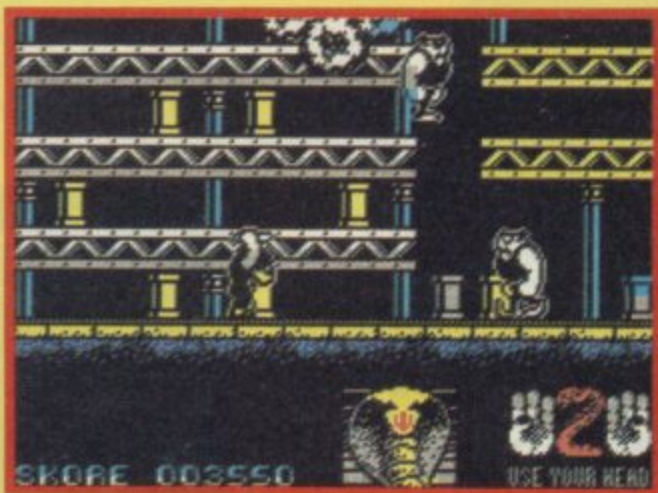

Finally! At last! Eventually! It's finished! The game for every would-be vigilante and boys called Marion. **Cobra** lumbers on to the software scene – a heavyweight in every sense of the word.

Just in case you were fortunate to avoid the whirlwind of media hype surrounding the film, I'll give you a low down on the plot. Crime has got a bit out

of hand in America, and the cops just can't cope. Tied down by laws that let criminals go free, the boys-in-blue have their hands tied.

Roll on Marion (Sly Stallone), a big lad with a tight T-shirt. He'll right the wrongs, catch the crooks, help the innocent and positively rake in the box-office takings.

In the movie, Stallone wasted absolute hordes of bad-guys, spraying his machine gun all over the place in a bid to make the streets a safe place to walk. In the game, you sprint along walkways, avoiding death which appears in a number of ways.

Amongst the foes that you encounter are large men with knives, flying missiles and women armed with rocket-

launchers. There are also some very mysterious pram things which whizz back and forth across the screen. I guess that they are a mere hindrance, and something not to be blown away, as each time one hits Marion, his arms wave about a bit, and he looks distressed.

Initially, your first line of defence is your head. Running around the walkways of the city, Marion will butt anything in sight when you hit the fire button. The only problem is managing to get within butting range before the target loses off one of their weapons. If you're too slow, you will end up running directly into a missile.

There are three sections in the game: city scene, rural area and factory. In order to get more impressive and effective weapons, you must collect beefburgers. Obvious, isn't it?

Your ultimate aim – apart from being able to claim having killed an absurd number of misfits and social dropouts – is to rescue the top "fashion model" Ingrid Knutsen from the arch-villan The Night Slasher (bool).

Although involving a lot of running around and shooting things, the program would be better pretending to be a straightforward shoot-out instead of a movie. The screen scrolls around, and the

## ARCADE



## REVIEW

movement is quite smooth. Some of the instructions are quite ridiculous – "If you try to kill Ingrid she may wander away". The music is OK though, and fits the 'style' of game very well.

### FACTS BOX

*Cobra is just what we all expected. Not great, it's pleasant enough, and not as disastrous as most licence deals*

**COBRA**  
Label: Ocean  
Price: £7.95  
Joystick: various  
Memory: 48K/128K

Reviewer: *Jim Douglas*



# BREAKTHRU

**B**reakthru is based on yet-another-ruddy-arcade-machine which, in turn, appears to have been based on **Spy Hunter**. Not wholly original, I grant you, but it's still a damned good chase through all sorts of terrain.

The idea of the game is that the most revolutionary fighter, the PK430, has crashed behind enemy lines (doesn't sound particularly revolutionary so far, crashing and all). Anyway, your objective is to drive through all manner of enemy defences in order to reach the plane. Then, well, I'm not sure, as I didn't come particularly close to this stage.

The graphics are pretty nice, scrolling from right to left quite smoothly. The screen is presented side-on, and an attempt at depth doesn't fall as flat as you may expect, as it's possible to move into the screen by pushing up on the joystick.

There seem to be few problems colour-wise, only becoming noticeably bad when leaping over enormous piles of rocks, causing your car to go a rather horrid red.

Obstacles present themselves in a variety of ways. There are little rocks (I think they are



rocks) which do no end of damage to your car, men with flame throwers, helicopters, tanks and jeeps. All of these are very dangerous indeed, and will finish you off with amazing ease.

A slightly more disconcerting fact is that the roads along which you drive will sometimes come to a complete halt. Either there is a huge hole plonked right in the middle, or you come across an apallingly large pile of boulders. Your only option is to hit the space bar and fling your super-mobile into the air. This part is a bit ridiculous, but is the only way out of such desperate problems.

You control your car by moving the joystick left and right, for decelerate and accelerate respectively, up and down for in and out of the screen, fire for fire, and space

**FACTS BOX**  
*Breakthru is essentially Spy Hunter edge-on. It's fun, easy to get the hang of, but hard to complete. And it's quite addictive*

**BREAKTHRU**  
Label: US Gold  
Price: £8.99  
Joystick: various  
Memory: 48K/128K

Reviewer: *Jim Douglas*



for jump.

The game comes in four stages, each depicted on a map, over-viewing the whole game.

As you progress, things become more and more difficult. Holes in the road crop up with more frequency, little men armed to the teeth will fire on you more rapidly, and you generally have a tougher time of everything.

It can get pretty hectic, and the only real snag is the fact that you have to use the keyboard to leap into the air. Otherwise it's great.



# DOUBLE



**Double Take** is strange.

The idea is this: due to unforeseen circumstances matter and anti-matter have met, two universes have collided and as a result things are pretty unstable. You have to get everything back to normal. The way you do this is to explore what could, in other circumstances, be the rooms of a **Wally** game (big graphics, household objects, a smidgen of attribute problems).

What you are looking for is, simply, things that are 'wrong' –

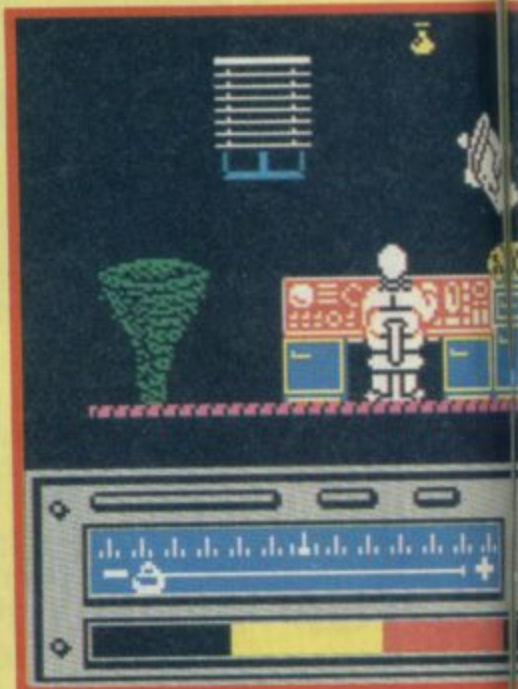

objects that are out of place and must therefore properly belong to the 'other' universe. You have to get such objects and, return them to the other universe.

Curiously enough (a sign that there are limits to how many new ideas you can actually get in a computer game) one way you can get the object back to the right universe is just to zap aliens. I forgot to mention the aliens, they are of marginally

## FACTS BOX

*Incredibly imaginative arcade game, with cart-loads of fresh ideas professionally implemented – deserves to be big*

### DOUBLE TAKE

Label: Ocean  
Author: Denton Designs  
Price: £7.95  
Memory: 48K/128K  
Joysticks: various

Reviewer:  *Graham Taylor*



**F**rankie goes to Hollywood was not a successful game. I mention this in the context of **Double Take** because **Frankie** got rave reviews and was regarded as incredibly inventive and imaginative.

**Double Take** is incredibly inventive and imaginative and if the same fate befalls it the game – buying public deserves all the appalling licencing deals based on terrible films it gets.

Actually reading the **Double Take** blurb boggles the mind. You get the sinking feeling the game is going to be absolutely impossible to understand. It isn't. At one level it's a straight zap-em-up, well, not straight exactly more multi-dimensional. At another level it's a leap (quantum) into a surreal world where realities mix and the familiar is odd.

## SINCLAIR USER CLASSIC



# CONTACT SAM CRUISE

**S**am is da strangest detective. He speaks like Bugs Bunny, does sommersaults to earn his dough and regularly gets hurled off the tops of buildings by agents of the Fat Man.

It's all part of the action in **The Case of The Bali Budgie** part of **Contact Sam Cruise**, Microsphere's long-awaited **Skool Daze** follow-up.

Budgies sing, so Sam's not surprised when he gets a message from a dame willing to spill her guts about the case on the top floor of the Hotel Royale.

He checks his antiquated detective's kit and prepares to leave the office, located on the second floor of a super-seedy tenement block. OK, so it's the 1930's and not so antique, but there are no laser scanners or fingerprint kits in this game.

Before he leaves Sam has to don one of his eight disguises because there's a contract out on him. There's a chef's costume, a postman, bar-room flossy and an old man. Some of them, the ones displayed in red, are known to the police, whereas the blue ones are

unknown to villains and cops alike.

Sam needs the disguise because as soon as he steps outside his door, as himself, he'll be gunned down.

As he moves from one window to another, down and across the building, you'll detect that the playing area is one vast scrolling view of city streets and buildings. You may not be able to see Sam going downstairs but he is, believe me.

When Sam hits the street, turning left on his way to the hotel, he finds gun men hiding in doorways and alleys, policemen on the beat and money drifting along da pavements.

Sam catches da dough by doing handstands and snatching it up in his teeth (seems reasonable enough). It's vital that he perfect his technique as his money dwindles during the case and if he goes broke that's the end! Sommersaults are also useful when dodging the hit men. The bullets may hit our hero but, because he's looping the loop in the air, their effects are minimal.

The technicolour 'tec – yes there is some colour clash – goes into the lobby of the Hotel Royale and slowly, very slowly, up to the top floor. He passes janitors and guests and janitors, all going about their everyday business – but any one of them could be a murderer!

Sam discovers a body on da top floor. The 'phone rings and a greasy voice slips into Sam's ear. The Fat Man's left the key to Number 19 at Number 31. As



well as receiving strange calls in the middle of murder scenes, Sam can also make them. To





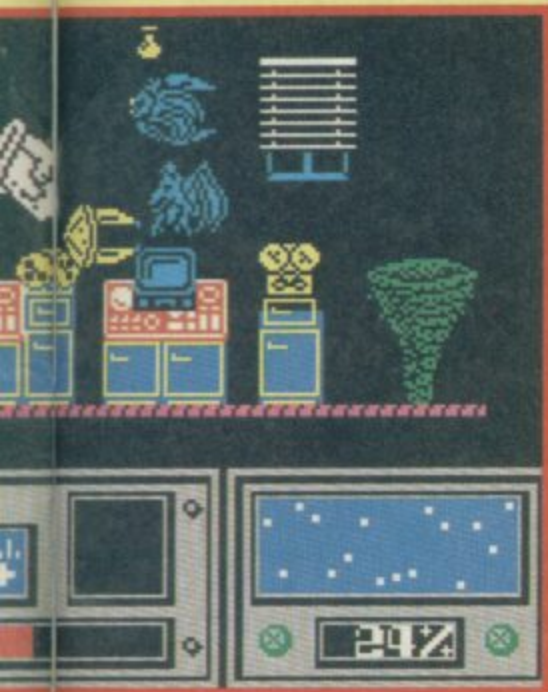

original design but appear in the tried and tested Ultimate style. You don't have to do anything other than kill them.

There are other ways of getting an object from one universe to another – the deeply mysterious 'sparkling cloud' is created which provides a tunnel.

So here's how it goes. You (a disembodied overcoat – and why not?) travel around entering and leaving a variety of

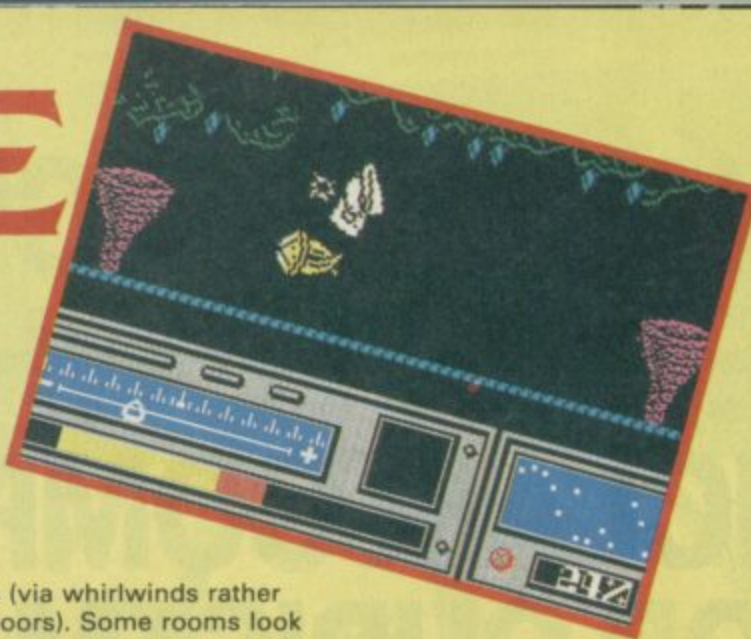

rooms (via whirlwinds rather than doors). Some rooms look like caverns, other rooms look like laboratories. As it happens I had my first success in the game in a room which was simultaneously an operating theatre and a woodwork room. Having spotted an object that looks somehow odd or out of context you pick it up and 'stabilise' it – sort of get its matter state back to normal – and then wait for the universe state to swing again (or cross universes via the sparkling cloud). Get the picture.

After playing the game for a little while, you realise that actually what we have here is not, despite all evidence to the contrary, some horrendously complicated strategy-cum-adventure-cum-sub-atomic-physics game but actually is just a damn fine arcade game, with more inventiveness than half a dozen other titles.

The graphics are good with effective use of a particularly neat 'dissolve' when the universe switches from one to the other – a process which

## ARCADE



## REVIEW

gathers pace as time passes.

The last section of the game after you have stabilised the universe concerns a battle with a cosmic being called Sumink (a joke I imagine). This involves first finding him/her/it in the anti-matter world using a series of sensor lights and then blasting – it feels a little like an afterthought but who cares?■

# DONKEY KONG

### FACTS BOX

*It's too little, too late. Here we have Kong, three years on and it's much the same. Progress? Who cares?*

**DONKEY KONG**  
Label: Ocean  
Price: £7.95  
Memory: 48K/128K  
Joystick: various

Reviewer: *Jim Douglas*



"Everyone," says Ocean "is going ape over Donkey Kong."

Tsk tsk. Not only is this statement possibly the most horrible pun in the universe, but it is completely untrue.

People weren't even particularly excited three years ago when Ocean's other version of the game appeared – Kong.

The plot centres around the kidnapping of the hero's blonde girlfriend by an enormous ape who attempts to escape on a platform of even-higher iron girders. Mario, the hero, must negotiate the assault course of falling barrels, fireballs and dodgy ladders.

In fact, when you take a long look at the two games – the original Kong and this effort – you realise that apart from some graphics changes, and some improved sound on the

new game, there has been virtually no development in the three-year space.

It seems that Ocean has merely put right most of the mistakes they made with the original Kong.

Hardly the correct idea really■

### FACTS BOX

*Sometimes unwittingly hilarious detective spoof with bold, irregular, graphics. Not a case for arcade gamers*

### CONTACT SAM CRUISE

Label: Microsphere  
Author: David Reidy  
Price: £9.95  
Memory: 48K/128K  
Joysticks: various

Reviewer: *John Gilbert*



kick off with the only number he knows is his own, but he'll collect others as the case continues.

He won't be making any now, however, as the police have arrived to arrest him for murder. A slow trip down-town to the police station, an interminable wait for bail.

Now try to get Sam into house Number 31 where the key to mysterious Number 19 is. He knocks on the door. If it opens he knows he's got the

key. If it doesn't he could break-in and risk getting arrested yet again – da police don't like Sam.

Once inside Number 31 Sam's on his guard. The villains are there and, if they grab the arm of his trenchcoat, they'll drag him on to the roof where it's a three-storey free fall to the technicolour spread on the pavement. If he's lucky he'll end up with a hangover and an empty wallet, while fun lovin' Daisy – his long-suffering secretary – goes off with the James' Gang.

Most of The Case of The Bali Budgie comprises getting arrested, being released, doing somersaults, being thrown off tall tenements and changing into ridiculous disguises. It's supposed to be a satirical look at the stereotype of an early '30s gumshoe, right down to the cliched language and situations. Some of it is funny. Some of it isn't.

The city plan is large, but by no means massive, and because the whole screen scrolls, the action is slow.

That's not to say that Sam Cruise is a bad game. It takes ingenuity to play and has the hallmarks of an excellent strategy/adventure.

It is not, though a fast arcade bash. There's little action but lots of thought■

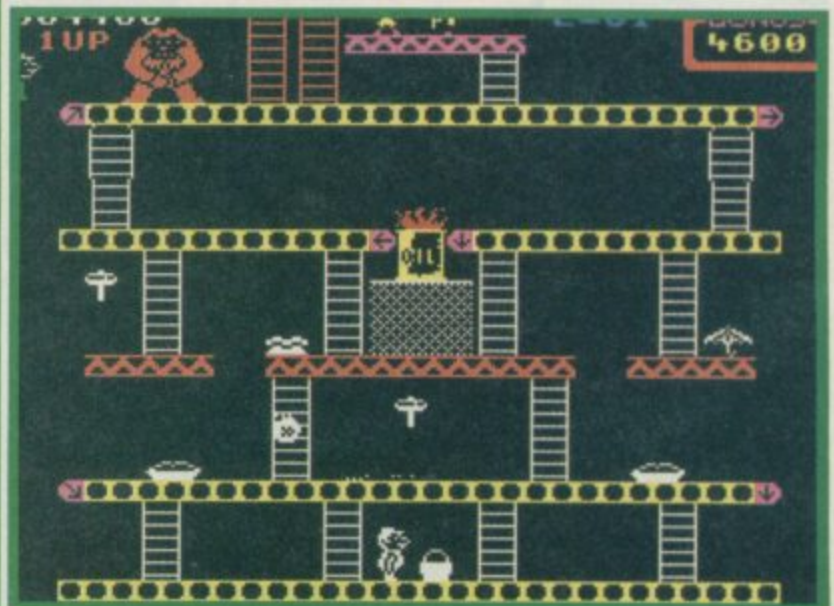

# A SPECIAL MESSAGE TO ALL THOSE PEOPLE WHO HAD A SINCLAIR COMPUTER FOR CHRISTMAS

(and those who have had one for years)

THE NEW YEAR  
MICROFAIR IS ON  
31ST JANUARY 1987  
AT THE  
HORTICULTURAL HALLS  
LONDON SW1

Looking for great gizmos for your new Spectrum or QL? There's one place you will find everything: THE MICROFAIR.

If it's new it will be on show. If it's original you'll find it on sale. If you need advice you only have to ask the exhibitors. If you want to meet thousands of enthusiasts, just come along and enjoy yourself.

There's everything for Sinclair Computers. Hardware, Software, Books, User Clubs, Programming Aids, Games, many at special 'show' prices — there's even a bring and buy sale.

For a fun day out and a chance to see and buy everything new and exciting . . . you won't beat the MICROFAIR.

## THE NEW YEAR MICROFAIR

31st JANUARY 1987  
AT THE HORTICULTURAL HALL  
GREYCOAT STREET/ELVERTON STREET  
LONDON SW1. 10am-6pm  
ADMISSION: £2.00 (ADULTS)  
£1.50 (KIDS UNDER 14 YRS)

### SEND NOW FOR REDUCED PRICE ADVANCE TICKETS

Send to Mike Johnston (Organiser), Dept S.U.  
ZX MICROFAIRS, 71 Park Lane, London N17 0HG.

Please send me advance tickets (Adults @ £1.50)  
Please send me advance tickets (Child under 14 @ £1.00)

Name: \_\_\_\_\_

Address: \_\_\_\_\_

**22** snsd  
**ZX MICROFAIR**

Please include a stamped, self-addressed envelope and make cheques/POs payable to ZX MICROFAIR.

Exhibitors ring Mike or Moira on 01 801 9172 for stand availability.





THE

# WARREN



**ocean**

*Spectrum  
7.95  
each*

Ocean Software Limited  
6 Central Street Manchester M2 5NS.  
Telephone: 061 832 6633 Telex: 669977

*Commodore  
8.95 each  
Amstrad*

# GREMLIN

ALWAYS AHEAD

## Footballer of the Year

The game to answer every boyhood dream - the chance to make it to the very top of football stardom. Starting on your path to glory as a 17 year old apprentice with a Fourth Division team and only £500 and 10 goal scoring cards in your pockets, the footballing world is at your feet. Adopt the identity of a professional footballer and develop a career through the ups and downs of match days, transfer deals and injuries etc. Display your talents in Football League, U.E.F.A. F.A. and Milk Cup games and then if you're good enough the ultimate accolade of your sport, the Footballer of the Year Award.

om First Division giants and opted to stay with Rovers. This promising centre-back has signed a new contract with team manager Derek Thorpe announced today.

**ALBERT DEBUT**

**FOOTBALLER OF THE YEAR**

**SALE** join Rovers for Record **BANKS**

Europe to new about his City.

Cooper for 12 months injury, broke week to make to a French medical treatment expert Pierre has treated other European Stars.

He is likely to join as City are prepared to transfer him from the club, however, he will be reluctant to leave with him.

United looked the more menacing side in the

**INJURED**

English International striker KENNY MORGAN could be out of action for the rest of the season because of a leg injury.

The injury also threatens his chances of making it into the National Squad for the world cup later in the year.

Morgan, aged 29, has missed a large part of this season because of several other injuries. He pulled a leg muscle yesterday in an exhibition game, after scoring a spectacular goal against Rangers.

## Footballer of the Year

C16 + 4 MSX Spectrum 48K

£6.95 £7.95

Amstrad, BBC/Electron  
Atari CBM 64/128

£9.95

## Avenger

C16 + 4 CBM 64/128  
MSX Spectrum 48K

Amstrad  
£9.95

# Avenger

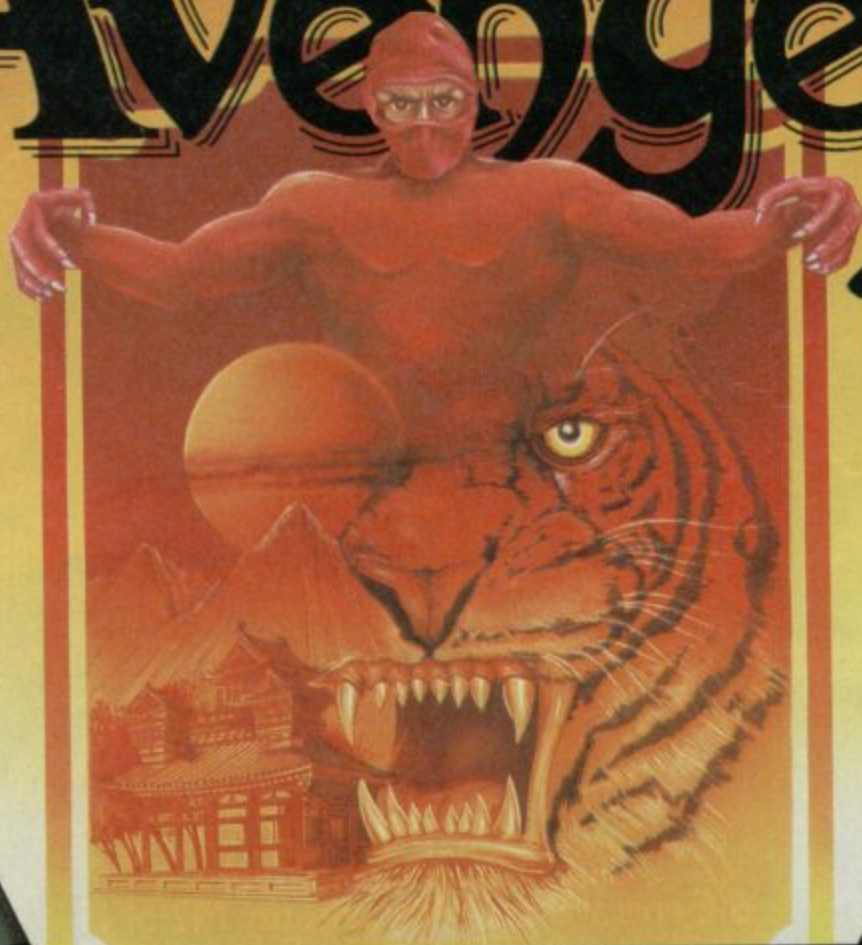

First came "The Way of the Tiger" the martial arts classic in which you had to prove your physical skills to become a Ninja. Now you have to prove your supreme mental agility in the second part of the Way of the Tiger saga "Avenger", the ultimate arcade adventure. Yaemon the Grand Master of Flame has assassinated your foster father Najishi and stolen the Scrolls of Ketsuin. You have sworn to the God Kiwon that you will avenge Yaemon's murderous act and recover the sacred scrolls. Your enemies are many, varied and all are deadly. All your skills courage and nerve will be called upon when you begin the final conflict in the Great Keep. Good Luck... only the brave hearted will survive.

Avenger (Way of the Tiger II)

Buy

C16

£6

Available

Way of

C16

£9

Available

Thing on

C16

£6

Available

Gremlin Graphics

Alpha House, 10 Carver Street

Available November

# GREMLIN

## D OF THEIR TIME

### Future Knight Trailblazer

C16 + 4 MSX Spectrum 48K

£6.95 £7.95

CBM 64/128

Amstrad

£9.95

### Disk

Amstrad Disk

CBM 64/128

Disk

£14.95

### Future Knight

Arise Sir Randolph to take up the challenge of death that has befallen the fair maid Amelia, held in the evil clutches of Spebott the Terrible. Acting upon an inter-dimensional distress signal from the galactic cruiser SS Rustbucket, don your Omnibot Mark IV attack suit and venture forth in pursuit of your beloved's captors. Defend yourself nobly against the Bezerka Security droids. Fight your way through 20 gruelling levels onto the planet's surface into Spebott's castle where the fate of Amelia lies with the outcome of your mortal combat with the awesome Hencho-droid. Is there any gallantry and bravery left in this modern day universe?

Available  
November

# FUTURE KNIGHT

# TRAILBLAZER

Thunder into the unknown at a breakneck speed, pushing your reflexes to their limits in this definitely exhilarating journey that's not one for the fainthearted. Roll left, roll right avoiding the endless chasms of doom that lay in and around the squares of mystery. Squares that will sometimes slow your progress, on occasion with fatal consequences and sometimes speed up unexpectedly or make you jump automatically. Keep a keen eye on the clock as the quicker you complete your task the higher will be your bonus. CBM 64 version is an amazing 2 player simultaneous game. Amstrad Disc version contains extra features.

Trailblazer

Available November

nder  
+4  
.95  
November

the Tiger  
+4  
.95  
November

a Spring  
+4  
.95  
December

Software Ltd.,  
Sheffield S1 4FS. Tel: (0742) 753423

# "GAMES AT THE SPEED OF LIGHT..."

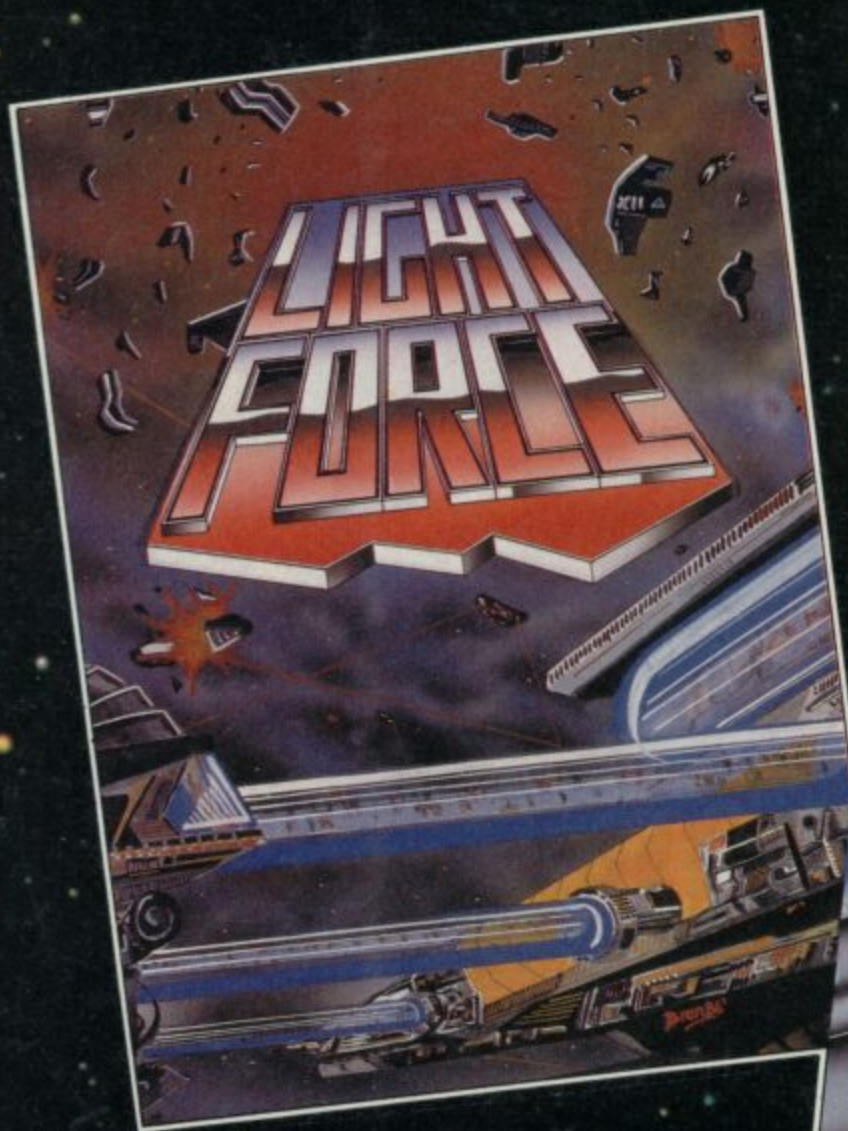

**LIGHTFORCE** is for **VENGEANCE**.....  
**LIGHTFORCE** is the Punishment Arm of Galactic Fighter Command.  
When a Terran-settled system at the edge of the galaxy is seized by an alien force, revenge comes in the form of a lone **LIGHTFORCE** fighter.  
**LIGHTFORCE** confronts alien in a dazzling battle above the strange landscapes of the Ice-Planet, the Jungle Planet, Alien factories and the impassable Asteroid Belt.  
**LIGHTFORCE** — at the speed of Light - from **FTL**.

**SHOCKWAY RIDERS** are the pick of the street gangs - **ATHLETIC, AGGRESSIVE & ARROGANT** - as they cruise along the triple-speed moving walkways that circle the great **MEGACITYS** of the 21st Century. **THE ULTIMATE AIM OF EVERY RIDER** is to go "**FULL CIRCLE**" - to do that, he must fight off the Block Boys, the Cops and the Vigilantes - as well as negotiating the Speed Traps and Rider Ramps erected by the angry local residents!  
**SHOCKWAY RIDER** is the most original arcade game of the year - **THE ULTIMATE FUTURE SHOCK!!**

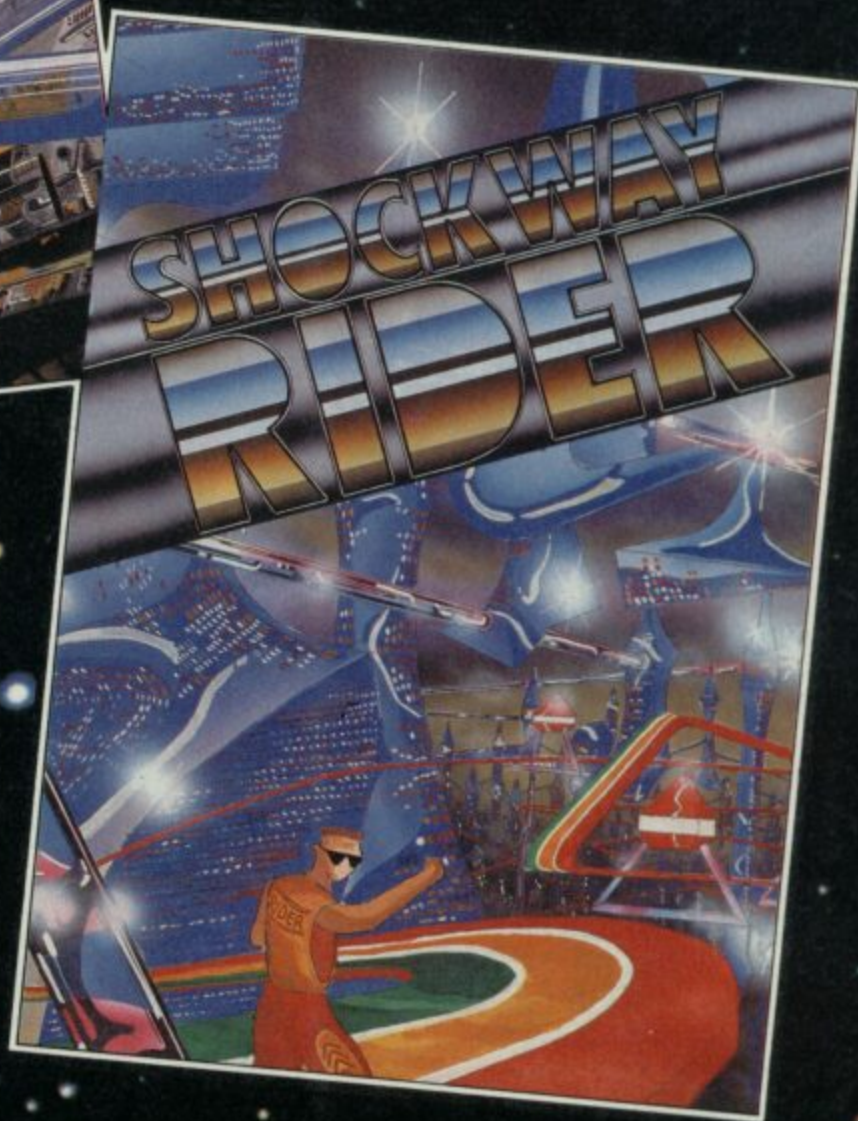

**FTL**  
**FASTER THAN LIGHT**

*LIGHTFORCE* AVAILABLE SEPT. '86  
*SHOCKWAY RIDER* AVAILABLE OCT. '86

SPECTRUM £7.95  
AMSTRAD & COMMODORE £8.95

FTL FASTER THAN LIGHT, CARTER FOLLIS GROUP OF COMPANIES,  
SEDGLEY ROAD EAST, TIPTON, WEST MIDLANDS DY4 7UJ. Tel: 021-520 2981 (4 lines)

**Z**ub is an unusual name for a game. **Zub** is unusual. **Zub** is the most astoundingly addictive game I've played this year. **Zub** has the second best soundtrack on the 128K+2 so far. **Zub** costs £2.99.

Beyond mere the addiction – the entire **SU** team was obsessed by the damn thing.

People queued up to play it, work stopped, memos were issued there was talk of locking it away.

It's fantastically amazing. Consider this a recommendation.

Try to play it on a 128K if you possibly can. It features all kinds of music, sonic noises and crazed explosions.

**Zub** starts in the way it means to go on. The opening screen is a mad title page with all sorts of ridiculous credits, next up is an insane control panel. Each panel scrolls around and around like a computer out of control, read it carefully and you'll find crazy error messages.

The game. There is you. And there is a thing. Sort of silly looking with long gangly limbs and a fearful expression.

The sum total of the plot of the game is as follows: you try to get from down (a planet surface) to up (where you get

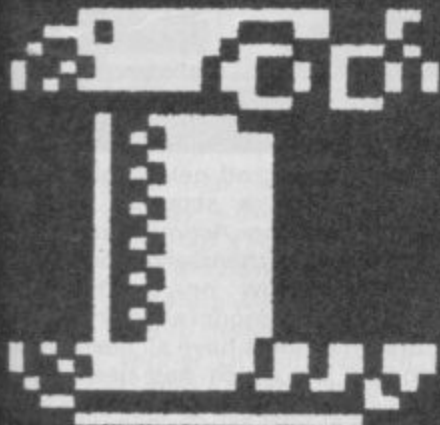

# ZUB

SINCLAIR USER CLASSIC

## FACTS BOX

*Possibly the most addictive arcade game released on the Spectrum this year. So simple yet it's absolutely stunning*

ZUB

Label: Mastertronic  
Author: Binary Design  
Price: £2.99  
Memory: 48K/128K  
Joystick: Various

Reviewer: *Graham Taylor*



BUDGET

£1.99  
£2.99

REVIEW

probably won't hit it though.

That's it. You keep trying to climb up using the platforms and you keep falling. Just when you think you have finally cracked it you fall a very, very long distance. The point is you get better. Gradually you learn some sort of technique and finally after about fifty times I got through the first level – playing it on 'Easy peasy' (on Level 4 it's, 'I would say' impossible. It was a pretty dramatic moment I can tell you. The next level features a different annoying alien (a jellyfish – see I told you I really did it) and in between is a sort of bonus extra energy section. Basically it's more of the same but who cares?

**Zub** is a vital purchase ■

picked up by a tractor beam and sent to the next planet). Getting up there is simple (theoretically). Jump up to a platform then 'ride' that platform until you find another one within jumping distance, and jump one step higher up. Then do it again.

Does it sound easy? Hah. Wrong. There's this thing, this sort of metallic mouth that sometimes sweeps down and knocks you off your perch. The higher you climb the further you can fall. You spend a lot of time falling in this game. The metallic mouth thing starts to get very irritating. There is some defence. You, **Zub** have a rather puny laser. If you manage to hit the mouth thing it goes away for a while. You

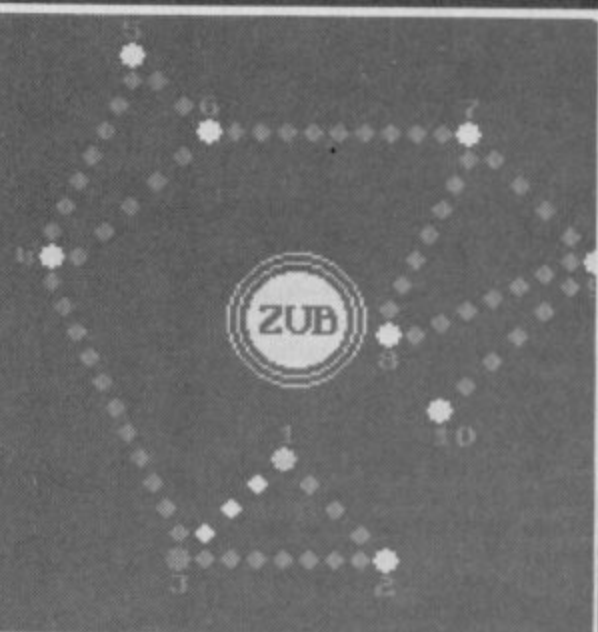

# OBLIVION

**O**blivion is well, pretty bad. Actually **Oblivion** looks like the sort of game software houses use as the 'demo' for easy-to-use games creator programs (that don't sell).

It's probably distantly related to some of Jeff Minter's ideas but really is as thrilling as a lecture on flower arrangement.

The front end of the game is misleadingly neat, big graphics for the joystick and keyboard select options – currently toggled choice waggles. Pretty slick you think. But no.

You are an Ostrich. Pretty macho eh? You have to walk or run across dozens and dozens an dozzzzennnnssss of screens.

Each screen with a small troupe of tiny non-animated sprites (well they sometimes bounce up and down a bit. Sometimes your bird jumps over them, sometimes you shoot at them.

On and on I passed through many levels, retired from the profession, bought a cottage

had grandchildren and died and still it went on.

Forty different levels and not

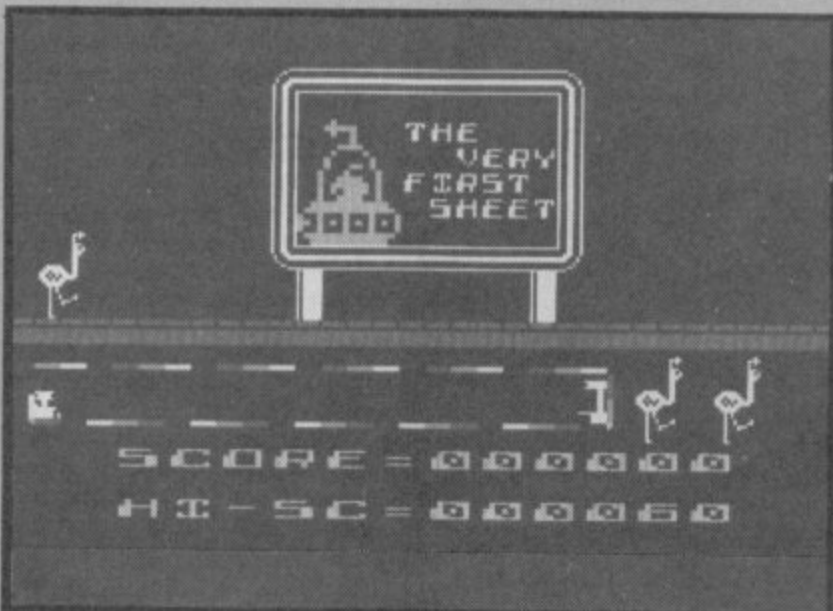

## FACTS BOX

*Screen after screen of terminally dull action. A quite exceptionally tedious game. Bound for oblivion on a fast train*

OBLIVION

Label: Alpha Omega  
Author: Simon Morris  
Price: £1.99  
Memory: 48/128K  
Joystick: various

Reviewer: *Graham Taylor*



a one less than completely dull: I know it's budget but honestly I'd rather go to Billingham

# JON RIGLAR'S

# ZAPCHAT



## Uridium

▲ is another great game from Hewson. Watch out for a ■ **Uridium** high score table in the near future. After at least ■ two-and-a-half minutes of ■ play, the cool team are able to bring you some tips on ■ how to complete up to Level 2. Here are some for Level 1.

- Level 1: Zinc
- It's best to fly as fast as you can. Although this sounds stupid, you find that sometimes you avoid death simply by being flukey
- Whatever you do, make sure you learn the layout of the section you are flying in. This will allow you to fly full speed without crashing nastily into walls etc
- Work out the routine of the enemy aircraft. At the start they all follow a set pattern, but your actions can change that
- Whatever you do, don't fly over a generator or stay in the same screen as a generator for too long. The generator will sense you're there and will send a mine after you. This on the whole, is very bad. You can get away with flying over one, provided that you are at full speed

**C**rimble is here at last! Amongst the millions of cards that have arrived, there'll be the usual dozen or so packs of white handkerchiefs and numerous pairs of bright green socks. You'll be pleased to hear that these will have been made good use of, each member of staff taking one and hanging it up over the appropriate fireplace. Graham plastered his with screen shots of *Lightforce*, John has sent his to Amstrad in the hope that they'll send it back with a 128K+2 inside (it's the only way we can get one!), David, the Ed, has converted his into a coffee cup.

Hidden somewhere in this column are tips for *Glider Rider* and *Great Escape* and the complete solution to *Dan Dare*.

- Your Manta spacecraft can fly through very small gaps by turning on its side
- In Level 1 it's best to stay at the top. Most of the craft attack from the middle.
- At the start press down to be sure that you miss the aerial!
- Again, learn the layout so that you can fly fast but with reasonable care
- The only difficult part is where you need to dive through a very small gap - here you need to do a special dive. Basically, follow most of the hints formed in Level 1 to be on the safe side. What I'm really saying is that I can't get much further and hope that by the time the next issue comes out I'll have better tips.

Now for some serious news. It appears that in the November *Zapchat* a cheat facility was quoted for

## Stainless Steel.

- ▲ The code was quoted as a,i,i,k and *Enter* - try pressing the letters s,i,l,k together instead. More serious grovelling here. After months of

Ricky Shell cheating his way down that endless road ▼

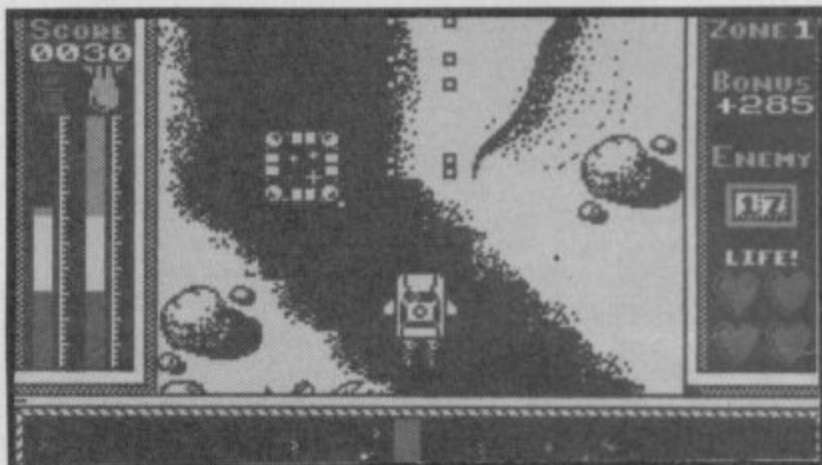

debating and wheeling and dealing we had hoped to bring you the **Highway** Editor thingy but the deal fell through! Ahhh! This is probably because Norm and our bodyguard tried to bounce its author around the room and he promptly left the country in the direction of foreign parts - Bognor Regis in fact. Commode has been kitted out with John Gilbert's espionage outfit and is running in the correct direction to try to get the proggy back. Perhaps next month...

Now for something completely different. The ideas department has found a use for all those high scores sent in to *Zapchat*. Loads of

## Paperboy

- ▲ high scores flooded the office last month and so, as a dummy run, a high score table was designed. So, what's so special about ours that hasn't already been done? Well, ours is a top eight instead of a top ten and that will do. Each month we're gonna set the *Zapchat* Challenge in which we name a game and you yank and crank that joystick to get a high score. If it works, we'll print the top eight the following month. Those who

try to cheat and get caught can choose a sentence - either playing *Action Biker* or throwing themselves out of a window on to the nearest Commodore factory. Staff members have all been locked up which has been causing quite a few problems. For the Feb issue we want your high scores for **Lightforce**, so get yanking etc...

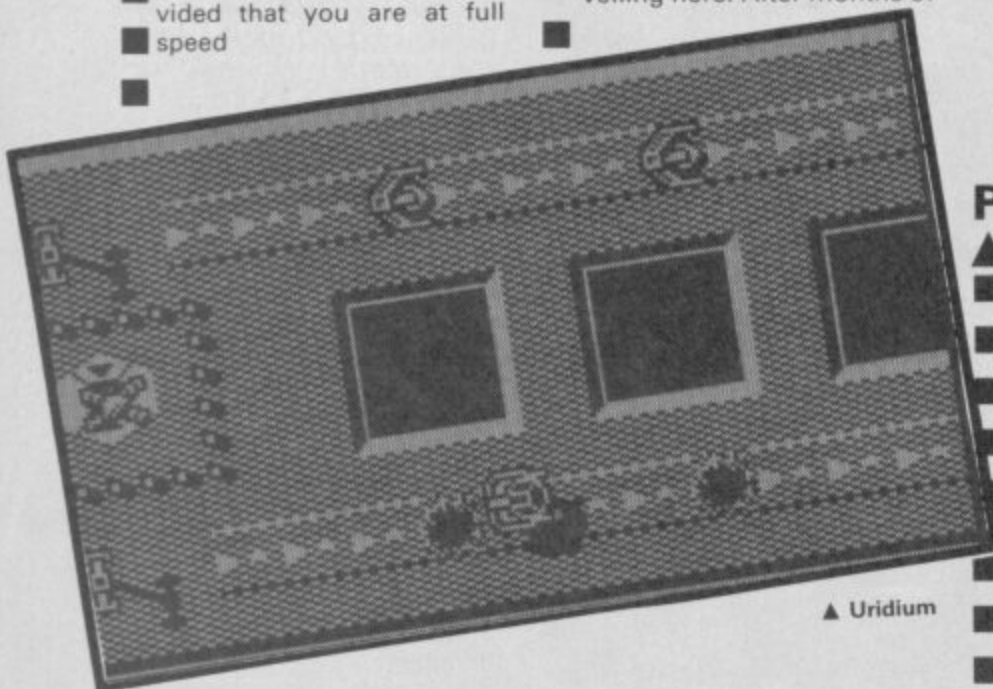
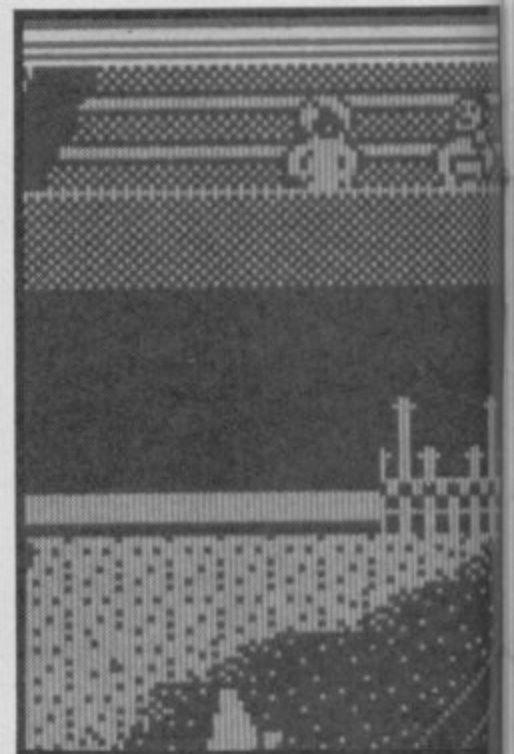

▲ Uridium



# MAP CHAT

## Zapchat Big Eight No 1: Paperboy

	Score	Name	Verdict
1	109,430	C. Sommerville	Must be fabrication
2	87,420	P. Lord	Sounds tacky
3	73,490	G. McLellan	Well um ...
4	70,190	S. Compton	Naff
5	68,480	I. Griffiths	Reasonable
6	69,290	D. Batterton	Poor
7	65,800	D. Norton	Very low
8	64,000	S. King	Last, Ha!
9	324	G. Taylor	You can't get away with it, Graham

Now it's **Light Force**, so no *Paperboy* high scores! and get back to your cage Graham!

On to more important things – like my pay! Only kidding! (You can stop hitting me now).

Before we go on, we'd just like to mention this month's winner of our 'Nut of the Month' award. It goes to Jean Rows who is apparently a *Headbanger's Monthly* spy and yet was stupid enough to tell us! Ya boo etc ... Jean comes from 'sunny' Bognor Regis and that explains a lot.

Compiled with the help of official EMAP Father Xmas, Matt Norman (you can tell who it is by his writing) – here's the special edition of

## Glider Rider

tips. Follow the instructions on how to destroy each reactor in turn, and use the incredible full-colour maps in *Map Chat* over the page as a guide. Use the overall plan of the playing area to find the ten arrangements of the reactors.

At the start drive around the reactors which we mentioned before and work out which line of action you are going to take. It's sometimes better to attempt the harder ones first and when you are low on energy press *Break*. If

you repeat this you'll find that eventually you will succeed in destroying the harder reactors. Now you must destroy the eight reactors that are situated outside the complex.

● **Reactor 1** This is a very hard reactor to destroy. Ride over to the side of the pylon, P1. Next ride into it to prematurely activate the laser. Provided you are quick enough, you can scarp down the slope and take off to bomb the reactor. Then run for it.

● **Reactor 2** Approach the pylon, P2, from the top of the hill to ensure that the laser doesn't shoot at you. If you're unsure as to the exact location of the reactor, then ride down from the top and go on until you hit a tree. You'll notice that the reactor is directly below the pylon. Climb back up and ram the pylon. As quickly as you can, ride down and take off at the lowest point. This takes some practice. Fly directly over the trees without landing on them (landing on them deducts marks off your energy). If you find that you're constantly going out of control, then try to gain more height when you first take off: Drop a bomb when you are roughly over the reactor.

● **Reactor 3** This has got to be one of the easiest reactors. Drive up to pylon, P3, and run into it. Roll back down the hill as quickly as you can. Turn round and take off as low down the hill as you can. Fly straight and bomb the reactor. You don't need to worry about the laser, because by the time you've destroyed the reactor, you'll disappear out of the screen and will be safe.

● **Reactor 4** Another hard reactor. Basically it involves a short take-off area coupled with lots of trees to sap your energy if you land on them. Activate the pylon, P4, and ride up the slope, turn right when you're beside the laser and drive down the opposite slope. Take off and try to gain height. Fly as straight as you possibly can to avoid unwanted tangles in the trees. If you've timed everything correctly, you should be able to bomb the reactor and get out of the screen with only minimal damage.

● **Reactor 5** Due to the short take-off area, this reactor can cause a few problems. Ride into the pylon P5 as usual to activate the laser. Then carry on along on the same level until you are roughly in front of the tree if you've still got time, then ride down the slope and take off. Once in the air, you are fairly safe as, if you bomb the reactor cor-

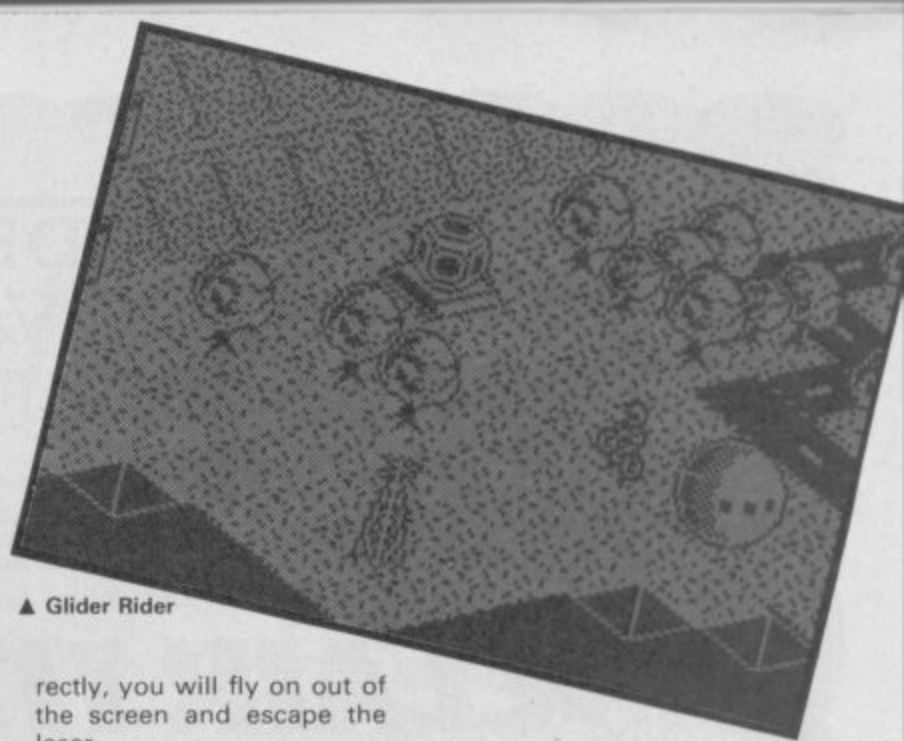

▲ Glider Rider

rectly, you will fly on out of the screen and escape the laser.

● **Reactor 6** This is where things start getting exciting. Stay on the middle level where the pylon is situated. When you've had a good look around – ride into the pylon and set off the laser. Quickly ride round the trees and head out towards the sea. When you start down the slope, turn round and take off. Bomb the reactor and press the *Down* key to make sure you land straight away. You'll also have to land in the right place, otherwise you could end up in the drink. Once you land, turn right and scarp as fast as you can.

● **Reactor 7** This is the easiest reactor of them all. It's on the other end of Reactor 3's hill. Climb the hill and activate the laser. Dash straight across and down the slope where you should take off as low as you can. Press *Up* once you're in the air and bomb the reactor. You shouldn't need to worry about the laser as you will disappear out of the screen as soon as the reactor is destroyed. Land as soon as possible once outside the screen.

● **Reactor 8** Don't panic! This may look daunting but it is, in fact, quite simple. Experiment driving from the laser to the reactor via the slope and vice versa. You might find that bumping into the tree before you go down the slope will help you judge a correct line for take off. When you're in the air, drop a bomb immediately and press *Left* to move your glider out of the screen before the laser can blast you.

Now check your energy – if you are below 40 then consider trying again – you'll need the energy when you're inside the complex. If you are lucky, and have plenty of energy left, then now it's time to get inside the complex itself.

By now you should be getting excited. To get inside

the complex is a fairly safe business, provided you've enough energy. You should have noticed that as soon as you destroyed the eighth reactor the rest were all activated. Don't panic – this is meant to happen. Drive around the wall until you reach the top right-hand corner. Climb up the nearest hill, take off and head for the wall. You will need to press *Up* to make sure you don't just crash into it and go out of control. It may well take a lot of practice, but there is always a nearby window to throw the computer or yourself out of.

Once on the inside, have a good look around and provided you have enough time left, you should find some interesting things. As you explore, it will become obvious that there is another wall which needs to be scaled before you can go further inside. The top right-hand corner of the complex will provide a safe take-off. Don't be put off by the fact that you are taking off from an activated laser! You'll need to direct the glider *Up* to make sure that you don't crash into the spikes. If you manage this then you have virtually completed the game. Drive around the complex and before you know it, you will easily locate the last two reactors.

● **Reactors 9 and 10** These are the last reactors to destroy and are inside the complex. I will tell you how to get inside in a few minutes, but first here's how to destroy them. Both are right next to each other and are incredibly easy to destroy. As you can probably see from the outside, the complex is designed out of Dragon 32s and other junk and useless materials. The reactors are placed in a dip which allows you a safe and unobstructed take off approach. Fly over and bomb the first one. No matter how hard you try,

# FREE WITH ORDERS OVER £30.00 IN VALUE £30.00 WORTH OF LEISURE TIME HOLIDAY VOUCHERS

Leisure Time Vouchers are redeemable at any ABTA Travel Agent

## SINCLAIR TITLES

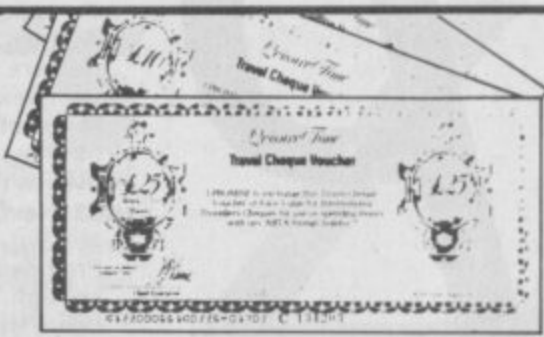

AND FOR EVERY EXTRA  
£1.00 YOU SPEND

YOU RECEIVE AN EXTRA  
£1.00 VOUCHER

### SOFTWARE

KNOCKOUT	£2.95
MATCH FISHING	£2.95
CODENAME MATT II	£1.99
EUREKA	£1.99
HIGHWAY ENCOUNTER	£3.95
ALIEN HIGHWAY	£3.95
T.L.L.	£2.95
NIGHTFLITE II	£1.99
LINKWORD GERMAN	£2.50
BOUNTY BOB	£3.95
BRUCE LEE	£3.95
LINKWORD SPANISH	£2.50
BEACHEAD	£2.95
ROBOT MESSIAH	£2.50
TECHNICIAN TED	£1.99
LAZY JONES	£2.50
WANTED MONTY MOLE	£2.95
EVERYONES A WALLY	£2.95
JASPER	£1.99
CHESS BY SINCLAIR	£1.99
CHEQUERED FLAG	£1.99
EMERALD ISLE	£4.50
ADVENTURE QUEST	£4.50
LORDS OF TIME	£4.50
SNOWBALL	£4.50
SABRE WULF	£2.50
BIZZICOM (BUSINESS CONTROL SYSTEM)	£2.95
PAC MAN BY ATARISOFT	£5.95
VALHALLA	£2.50
TWIN KINGDOM VALLEY	£2.95
PSYCHEDELIA	£1.99
QUICKSILVA WORD PROC.	£1.99
BRAXX BLUFF	£1.99
DEATH CHASE	£1.99
HEATHROW A.T.C.	£2.95
ADVENTURELAND/SECRET MISSION	£3.95
ROBIN OF SHERLOCK	£3.95
KOMPLEX	£1.99
VIDEO POOL	£1.99
SPACE RAIDER CARTRIDGE	£1.00
INTERNATIONAL KARATE	£5.95
CYBERUN	£3.95
GOLFING WORLD	£2.50
PINBALL WIZARD	£3.95
BEAMRIDER	£2.99
SPACE SHUTTLE	£3.50
3D LUNAR ATTACK	£1.99
10 MEGA HITS	£5.95
SPIDERMAN/HULK	£2.99
STARBIKE	£2.95
PSYTRAXX	£2.95

WILLIAM WOBBLER	£3.99
TOY BIZARRE	£2.95
TWISTER	£3.99
TALOS	£2.99
JUGGERNAUT	£2.99
BLADE RUNNER	£2.99
THE COVENANT	£3.50
MANTRONIX	£3.99
DALEYS SUPERTEST	£4.99
FRIDAY 13th	£2.99
GUNFRIGHT	£3.99
ZORRO	£3.50
DEATH STAR INTERCEPTOR	£3.99
ASHKERON	£1.95
MONTY ON THE RUN	£3.95
NEVER ENDING STORY	£4.95
SPELLBOUND BY BEYOND	£1.99
BIORHYTHMS	£0.99
GIFT FROM THE GODS	£2.95
CONFUZION	£1.99
THE TRADING GAME	£1.99
THE INFILTRATOR	£7.50
ALIENATE	£2.99
KNIGHT LAW	£3.99
AMERICAN FOOTBALL	£4.95
SKY FOX	£3.95
METABOLIS	£3.95
WEST BANK	£3.95
BOUNDER	£3.95
EDDIE KIDDS JUMP CHALLENGE	£2.95
SAM STOAT SAFE BREAKER	£2.99
JEFF CAPES STRONGMAN	£2.95
REVOLUTION	£3.99
TAU-CETI	£4.95
FACTORY BREAK OUT	£2.95
MANIC MINER	£2.95
SCRABBLE BY SINCLAIR	£4.95
TITAN DEBUGGING-MON-UTILITY	£2.95
SUPERCHESS 3.5	£3.95
WHO DARES WINS II	£2.99
FIGHTING WARRIOR	£3.95
FRANK BRUNOS BOXING	£3.99
TERRORMELINOS	£3.95
GYROSCOPE	£3.95
NOMAD	£3.95

### EDUCATIONAL PACKS

PHYSICS 'O' LEVEL and 'A' LEVEL, MATHS 'O' LEVEL, CHEMISTRY 'O' LEVEL, BIOLOGY 'O' LEVEL	£9.95
COLLINS PADDINGTON PACK PADDINGTONS EARLY VISIT, PADDINGTONS GARDEN GAME, PADDINGTON AND THE DISAPPEARING INK	£7.95
HILL McGIBBON PACK PUNCTUATION PETE, BALLOONING,	

CAR JOURNEY, SPECIAL AGENT	£7.95
LONGMAN SOFTWARE 6-10 YEARS SUM SCRUNCHER, ROBOT RUNNER, WILD WORDS, A.B.C. LIFT OFF	£6.95

**SPECTRUM EDUCATIONAL BY SINCLAIR/McMILLAN - ALL TITLES £2.99 EACH**  
PLANET PATROL, CARGO, GLIDER, MAGNETS, SOUNDABOUT, SPELLBOX, DISEASE DODGERS, WEATHERMASTER, WORDSETTER, OIL STRIKE, MACMAN & THE CABER EATER, MAC MAN IN THE TREASURE CAVES, ALPHABETTER, MACMANS MIRROR IMAGE, MACMAN AND THE GT ESCAPE, BODYSWOP

<b>GRIFFIN SOFTWARE PACK INC.</b> 5 YEARS AND OVER TABLESUMS, NUMBERFUN, GET SET	£5.95
--	-------

<b>GRIFFIN PYTHAGORAS PACK INC.</b> 10-15 YEARS THEORUM OF PYTHAGORAS, FORMULAE & COMPOUNDS, FUNDAMENTAL ALGEBRA	£5.95
--	-------

<b>GRIFFIN MATCHS &amp; CHEMISTRY PACK</b> 10-15 YEARS ATOMS & MOLES, INTRO TO TRIGONOMETRY, MENTAL ARITHMETIC	£5.95
--	-------

### GAMES PACKS

<b>SILVERSOFT PACK INC.</b> SUPERMUTT, ARCADE ACTION ORBITER, STARSHIP ENTERPRISE, CYBER RATS, ARCADE ACTION, SLIPPERY SID	£5.00
CODENAME MATT II, VIEW TO KILL, FRIDAY 13th, TEST MATCH, BEAKY & THE EGG SNATCHERS, THEY PYRAMID	£5.95

<b>IMAGINE PACK INC.</b> STONKERS, PEDRO, ALCHEMIST, ZZOOM, ZIP ZAP, CONQUEST	£3.95
--	-------

<b>ON THE OCHE INC.</b> SNOOKER, WORLD CUP FOOTBALL, OLYMPICS, GOLF, DERBY DAY	£5.00
---	-------

### UTILITIES

QUICKSHOT II WITH M/S	£10.95
ALPHACOM PAPER 5 ROLLS	£ 8.95
CURRAH MICRO 5 SLOTS	£ 2.95
COMPUTER TO T.V. LEADS	£ 1.50
MICRODRIVE CARTRIDGES	£ 1.99
ALPHACOM/TIMEX 32 PRINTERS	£31.95
SPECTRUM ADDITIONAL DRUM KITS:	
LATIN	£3.99
AFRO	£4.99
ELECTRO	£4.99

p&p 75p all orders  
overseas - £1.00 per tape,  
£2.50 packs, £5.00 peripherals

### LOGIC SALES LTD

6 Midgate - Peterborough - Cambs  
24 hour ordering on 0733 313870

For Your **SPECIAL OFFERS**  
**SPECTRUM/PLUS/128K**

**QuickShot II**

INCLUDING INTERFACE  
PLUGS STRAIGHT INTO SPECTRUM/PLUS

ONLY **£13.99** POST FREE

- TOP + TRIGGER FIRE BUTTON
  - AUTO FIRE MODE
  - KEMPSTON COMPATIBLE
  - STABILIZING SUCTION CUPS
  - SPECTRUM OR PLUS • UNBEATABLE OFFER
- SEND FOR INSTANT DESPATCH



PRICE BREAKTHROUGH  
**SWITCHABLE JOYSTICK  
INTERFACE**

ONLY **£8.99** POST FREE

- ALL THREE SYSTEMS AT THE FLICK OF A SWITCH
- 'KEMPSTON' - 'CURSOR' - 'INTERFACE II'
- ACCEPTS ANY 9 PIN JOYSTICK - INCLUDING RAPID FIRE MODELS • SPECIAL OFFER!!

Buy with QUICKSHOT II complete for only **£14.99** SEND NOW



Now you can backup all your Spectrum Games to Microdrive or Tape.

- Simply press a button to "freeze" the program.
- Save to micro drive or tape
- Special program compacting techniques
- Code Inspector allows you to freeze the action, add pokes and restart the game again. Also peek facility.
- All backups will restart from the point they were saved.

**IMPROVED MODEL!**  
ONLY **£24.99** POST FREE

**ROBOTICS & MODEL CONTROL**  
Made easy on your Spectrum

- 4 independently controllable outputs for robotics, motors, lights, etc.
- 8 independent inputs for sensing etc.
- This is the unit that the "Legu" publication "Make and Program your own Robots" was based on • Complete with all cables • Easy to use

**£29.99** POST FREE



Now you can create Superb Graphics easily with  
the New **Lightwriter**

NOW ONLY **£14.99** POST FREE

Lightpen comes complete with Interface & Software

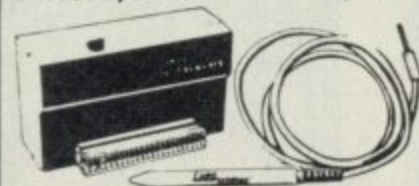

- Just plug in the Datel Lightwriter and draw circles, squares, rectangles, make superb hand drawings, paint, fill, erase, choose inks, paper, colours.
- Save your results into memory (48K) and use in animation or save onto tape to use in your own games.
- All functions selected from screen menu with the lightpen.
- Unbeatable value. • Nothing more to buy.

SEND NOW AVAILABLE FOR IMMEDIATE DELIVERY

**Digital Sound Sampling Technology. NOW Available on your Spectrum**



New Fully Integrated Software Supplied - Previous purchasers can upgrade for £5.00

Complete unit and Software Package  
**£49.99** POST FREE

• Digital Sound Sampling has only previously been available for large micros and costing at least 10 times the amount • The sound Sampler allows you to record "Digitally" any sound into memory and instantly replay it at any pitch, forwards, backwards, ascending scale, compressed, expanded, with echo, endlessly looped, etc. • Supplied complete with Software package to facilitate the above operations, plus on screen "Voice Prints" • Frequency Plotting • Wish on screen keyboard • drum kit • whole system symphony could be produced from a single Sample Sound • This is a professional unit featuring 8 Bit D to ADC converters as used in Digital equipment now sweeping the music world. • Although the unit is not a toy, giving truly astounding results for the musically inclined, we have incorporated a games interface to allow you to use Sound Sampling in your own games etc., so the Sound Sampler would be of interest to everyone.



**Centronics Printer Interface**

ONLY **£24.99** POST FREE

AVAILABLE NOW!!  
**UNBEATABLE OFFERS**



Games Ace features:  
KEMPSTON COMPATIBLE • JOYSTICK INTERFACE  
ACCEPTS ANY 9 PIN JOYSTICK INCLUDING RAPID FIRE MODELS  
PLUS DELIVERS THE SOUND FROM YOUR GAMES THROUGH TV SPEAKER. (Fully controllable)

ONLY **£10.99** or complete with QuickShot II only **£17.99** POST FREE

- Suitable for any Centronics Printer
- Complete with Printer Cable
- Microdrive Compatible
- Tasword Compatible
- Hi-Res Screen Dump (Edson)  Easy to use



USUALLY SAME DAY DESPATCH ON ALL ORDERS  
SEND CHEQUES P.O. TO  
UNITS 8/9  
FEN) ON INDUSTRIAL ESTATE,  
DEWSBURY ROAD, fenton,  
STOKE ON-TRENT TEL: 0782 273815  
FAX: (0782) 264510

24 HR CREDIT CARD LINE  
FOREIGN ORDERS ADD £2 POSTAGE

THE LEGEND OF  
**APACHE GOLD**  
by  
**Peter Torrance**

Lonesome Cowboy 'LUKE WARME', not a Dime to your name and only dreaming of riches. But there is a LEGEND. A legend of great riches in an Indian Burial ground.

The legend of . . . APACHE GOLD!



From the producers of  
**THE GRAPHIC ADVENTURE CREATOR**

Available from all leading retailers.

Or direct from:  
**INCENTIVE SOFTWARE LIMITED**  
2 Minerva House, Calleva Park,  
Aldermaston, Berkshire RG7 4QW.  
Telephone: (07356) 77288.

**PRIORITY ORDER FORM**

Please rush me for my Spectrum

Commodore 64  Amstrad CPC

Apache Gold  £7.95  Winter Wonderland £7.95

Graphic Adventure Creator { Tape £22.95   
Disc £27.95

I enclose cheque/PO or please debit my credit card

No \_\_\_\_\_

Name \_\_\_\_\_

Address \_\_\_\_\_

# MAP CHAT

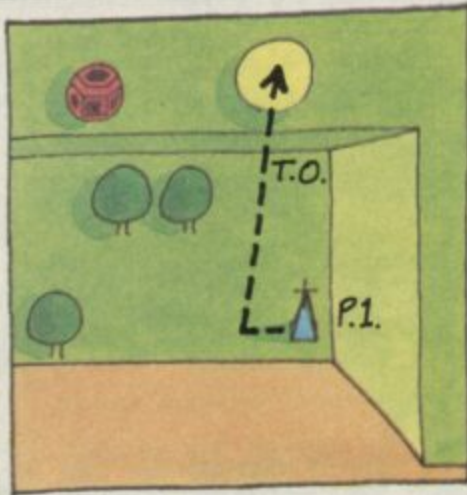

REACTOR 1.

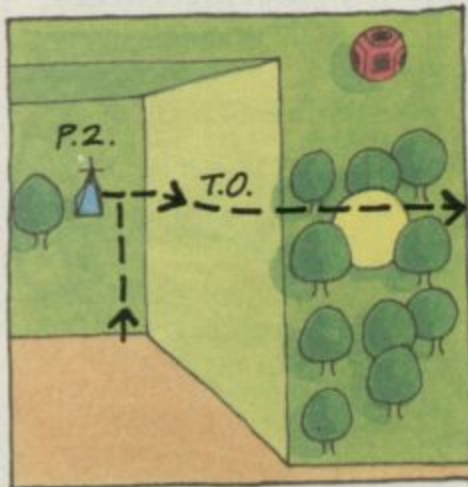

REACTOR 2.

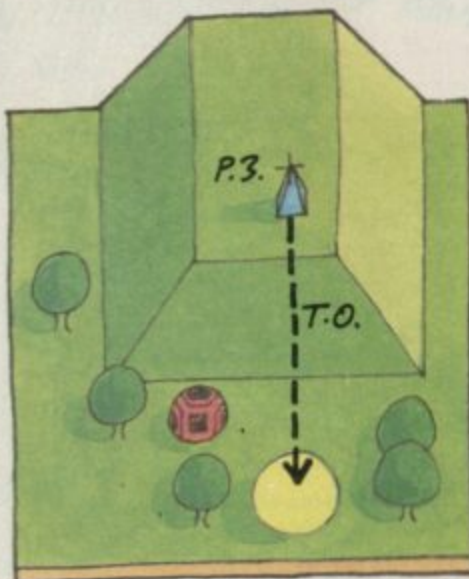

REACTOR 3.

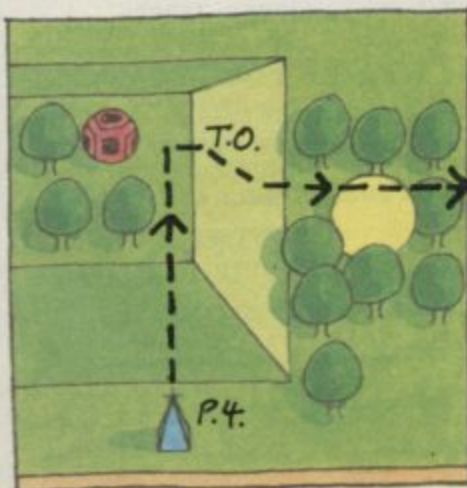

REACTOR 4.

you will not be able to destroy both at the same time. So, land and turn round. Drive back to the same take off area and repeat the same procedure.

Once these are destroyed, turn round and scarper back the way you came. When you are outside the complex, drive to the nearest hill and take off in the direction of the sea.

Here's the disappointment. Nothing else happens except a message appears. No fancy 128 tune or finishing sequence, no opportunity to play again at a different level or anything at all. You don't even see your sub! The rather puny message that

appears says: 'You've complete the game and escaped with your life - don't let it go to your head!'

The art department has been working overtime this month and has great festive jolities in presenting this 3D map of *Glider Rider*. It shows roughly the location of the ten reactors. To enable you to see the 3D effect you will need the wonderful and totally original spectacles. If for some reason these are absent, then rush to your newsagent and shout obscenities at him. If they're present then something's wrong. If I'm having you on then I'm a computer journalist.

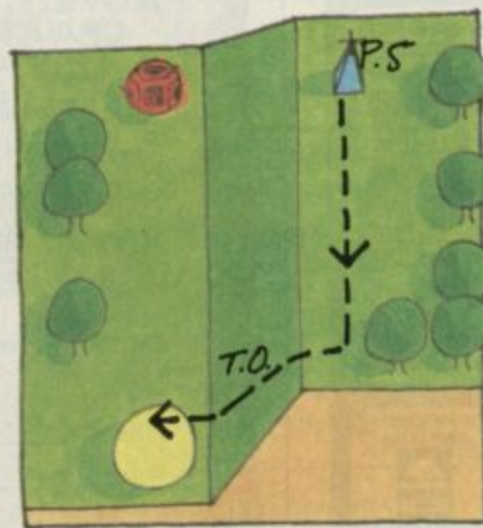
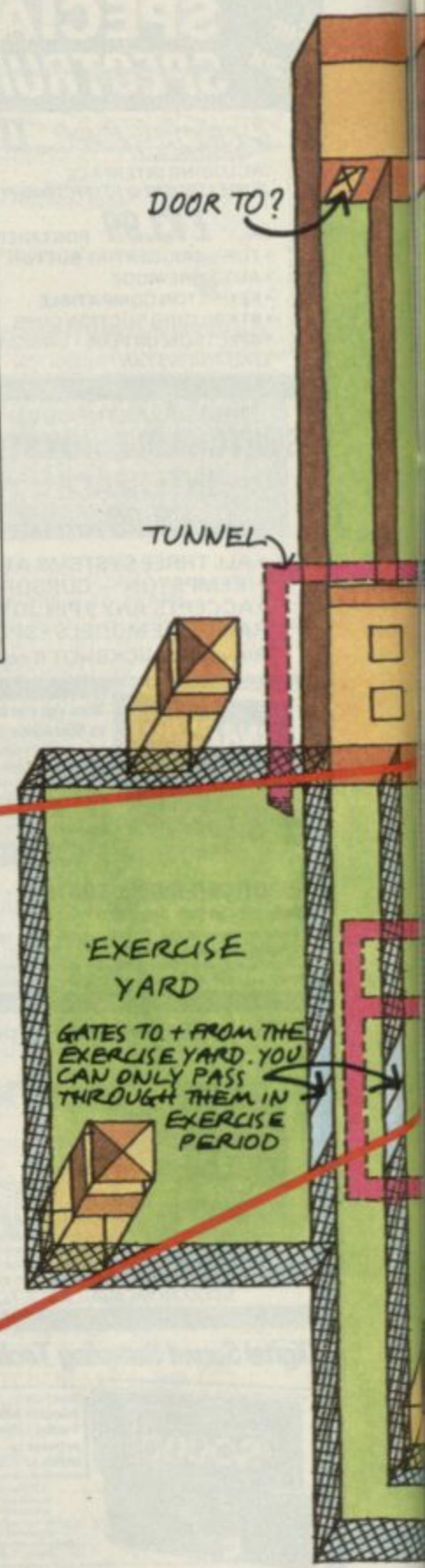
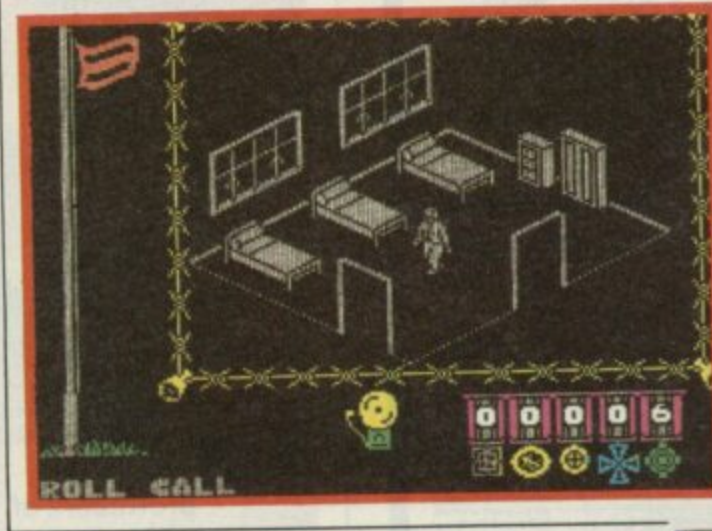

REACTOR 5.

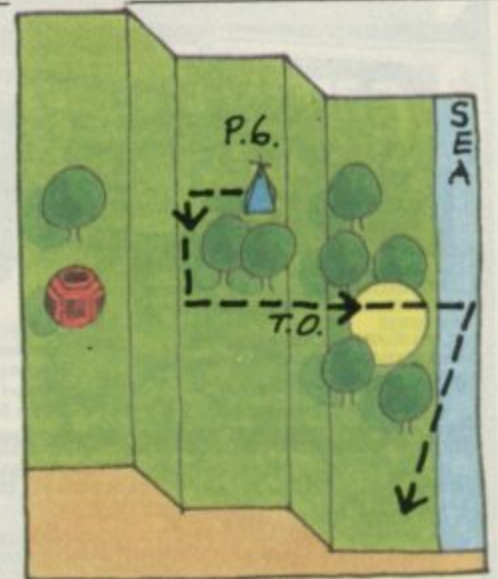

REACTOR 6.

# MAP CHAT

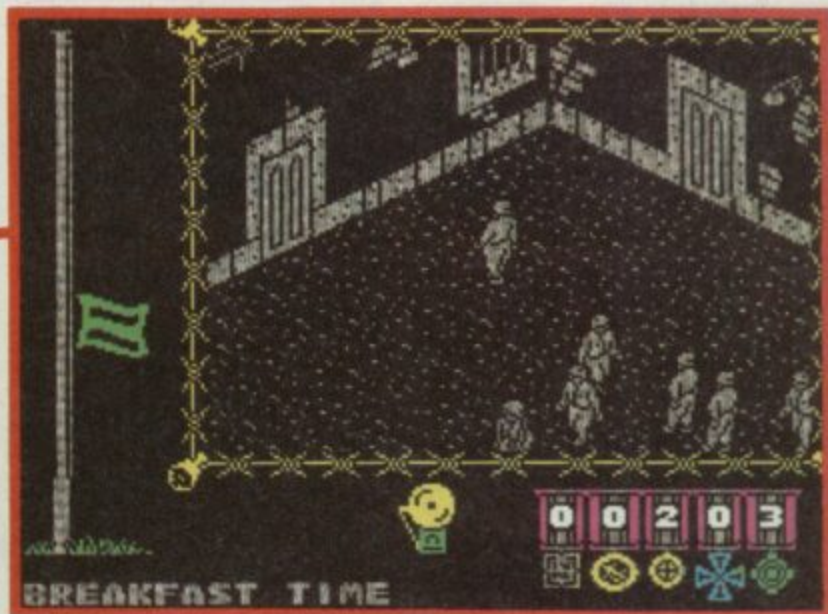
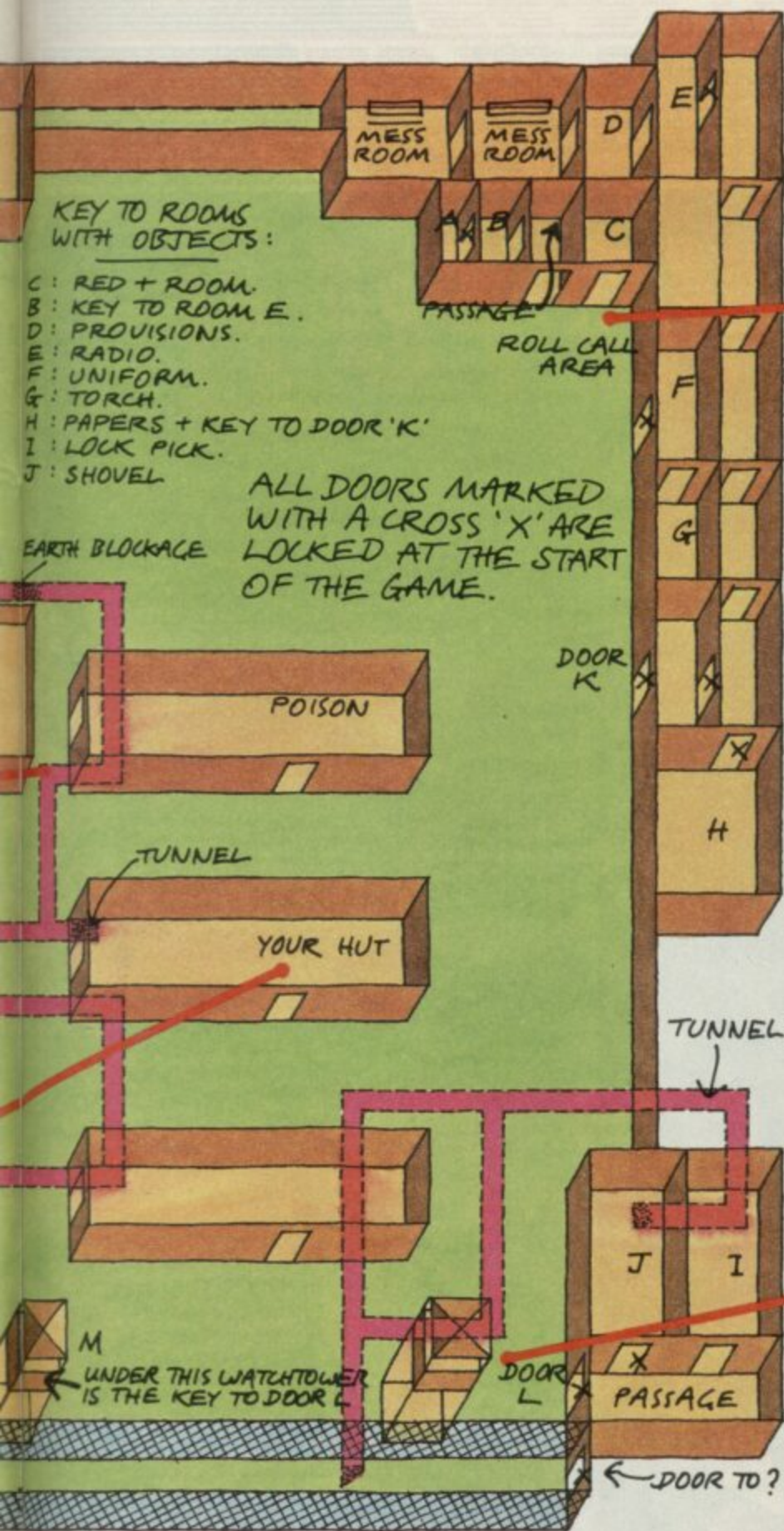

Here's another morsel to wrap your teeth around. Here's how to complete

## Great Escape

▲ for any of you who should wish to, old bean. Charlie Morgan has sent loads of tips and a map - printed here in glowing technicolour. To start off with let's see what each available item does:

- German Uniform: Very, very useful. Pick up what looks like a pile of old blank-

ets and use them. You will be transformed into a German guard. This disguise will allow you access to parts other uniforms cannot reach. Watch out for the Commander though, he'll recognise you even in the garb. Note, when you appear from the tunnels, you'll need to wear the uniform again.

- Provisions, Radio: Nothing but red herrings. You can't even listen to the Pubslinger on Radio One

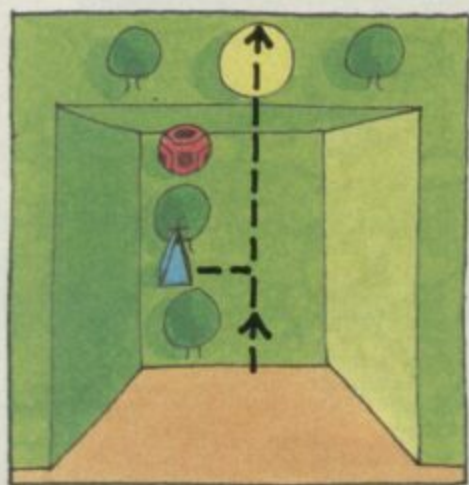
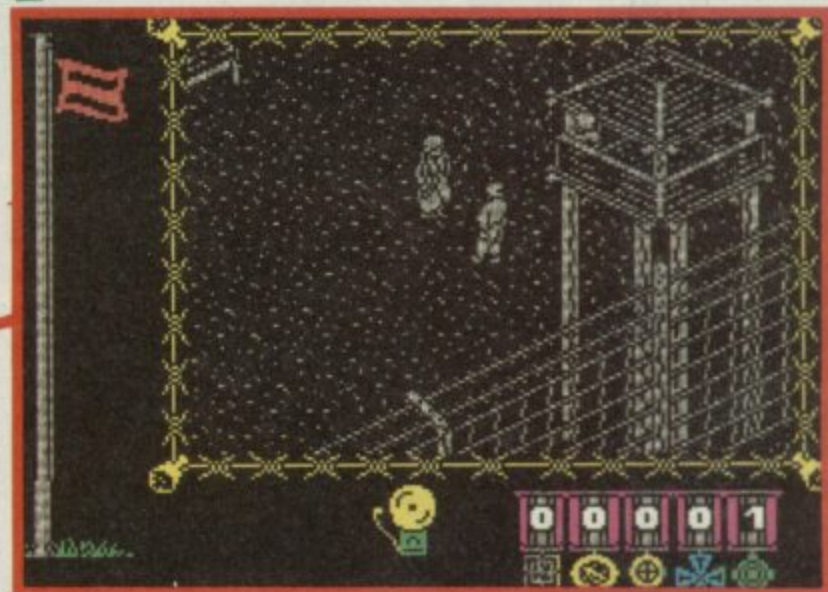

REACTOR 7.

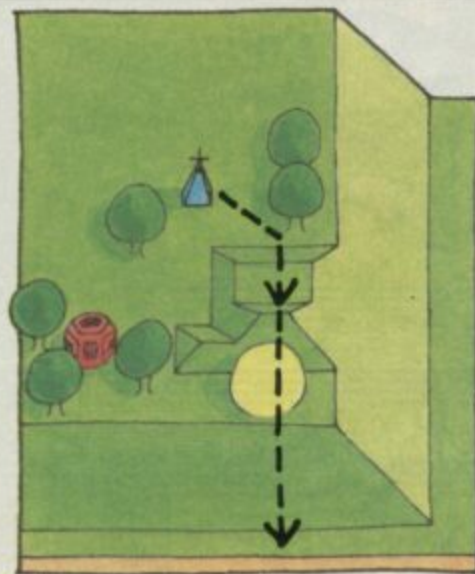

REACTOR 8

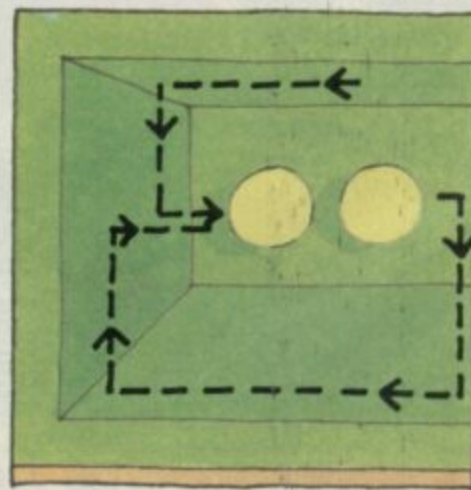

REACTORS 9 + 10

AMSTRAD 18-95

ZX SPECTRUM 17-95

COMMODORE 64 18-95

# Yie Ar KUNG FU II



*...the name  
of the game*

The officially endorsed game by

**Konami**®

**Sequel to the hugely successful Kung Fu simulation.**

Eight more deadly opponents to combat as you develop your karate skills and advance to become a black-belt master.

Authentic fighting moves with 4 different locations create an outstanding and realistic atmosphere.



# FESTIVE QUIZ!

**T**hink you know about computers? Then this isn't the Quiz for you. The Sinclair User Christmas Quiz has been especially designed for those who wouldn't know a bus if it ran them over and those who think chips were always better wrapped in newspaper. Could you make it in the computer world? Find out below:



## IF YOU WERE A PROGRAMMER...

- 1) Sir Clive Sinclair approaches you at a party with a job offer working on a serious computer based on latest transputer technology - it will have a keyboard made of sticky-back plastic. Do you:
- Look impressed and say "tell me more".
  - Laugh hysterically
  - Offer financial backing
  - Pretend to be unwell and run to the loo.



## YOU ARE AN ORDINARY PERSON...

- 2) You are thinking of buying a computer in a well known electrical chain store. You would like some information. Where do you find it?
- From a colour advertisement in the *Sunday Times*

- b) From Norman Bates (you can read the little plastic label on his nasty junior management

- type suit) who works in the computer department of the store.
- From a man next to you in the shop who says he had just had to return his sixth computer because it does not work properly.
  - From Sinclair User magazine (Price £1.00 monthly)

## YOU ARE A SOFTWARE HOUSE...

- 3) You are the owner of a software house called Firework software (They're Explosive! is the imaginative ad copy.) You decide to launch a budget range. What do you call it?
- Sparklers
  - Squibs
  - Squirts
  - Bangers
- 4) You are about to launch a Christmas title. Which best describes it?
- A mammoth multi-part graphic adventure that's taken five years to finish and pushes the Spectrum to its limits.



- A serious but extremely useful business utility
- Based on *Sky Angels* a recent Hollywood blockbuster starring Tom Voyage, released on twelve formats, awful on every one.
- Probably not actually going to be out by Christmas as such except possibly on the ST.
- Firework Software is about to launch a mammoth five cassette adventure. It comes with an enormous map and a 300 page booklet. This begins "Long ago in the time beyond time in the dark land of. . ." What would be a suitable name for the dark land?
  - Belgravia
  - Rhyll
  - Tharg
  - Nooky Vale
- The mystic orb which features prominently in the game (stolen from the elves by the Prince of Elron) is known as the orb of. . . ?
  - Tharg
  - Ajax
  - Vim
  - Zircon
- The hero's name?
  - Ron
  - Brenda
  - Tharg
  - Tel
- The adventure is complete and is, quite honestly, appalling. How are you going to get a good review?
  - Introduce the editors of the magazines to Muggor Marty your new public relations man who says "I am an ex-paratrooper and member of the SAS and don't like to see bad fings written about Firework products."
  - Offer it to one magazine only, telling it the game is an exclusive, bring it over in a suitcase with two armed guards to emphasise the effect.
  - Take several pages of advertising space
  - Send over Brian Blunter, a company minion, to the magazines to ask discreetly "Eh how much does it cost for a good review?"

**HOW DID YOU DO?**

Add up your total number of points and check your industry rating below:

0-5 Oh dear, I'm afraid you have an awful lot to learn. You are so naive you probably still believe that one day people will learn to live together in perfect peace and harmony.

51-150 You're beginning to wise up about things but you have a long way to go. Reality is even worse than you are beginning to suspect.

151-300 You've been around, probably bought a few dull tapes, had your computer blow up a few times and been told a complete pack of lies in high street shops. Somehow though it all you stick with computers because, what the hell, they're a lot of fun aren't they?

14 a 10 Points. Yep, this is naff enough (c.f. *Sunday Times*).

b 10 Points. Also good. As colour supplements take such a long time to be organised you often find defunct computers are on offer as prizes.

c 10 Points. Semi-defunct software too.

d 0 Points. No, you don't give away anything anybody might want.

15 a 10 Points. Yep, this will do. Trite, dull, banal and with the exclamation mark at the end.

b 0 Points. This is similar to a line used by Amstrad. This will almost certainly involve some of the most expensive lawyers you've ever seen. . .

c 5 Points. Bit naff, and lacks that vital exclamation mark.

d 0 Points. Ho hum.

16 a 0 Points. No, aside from having extensive hair this man is clearly a mason. Sir Clive is a bald member of Mensa.

b 0 Points. No, you get something for nothing from Santa Claus. This man won't even give you a sensible joystick port.

c 20 Points. Yes it's honest Al himself having a merry Christmas time and wishing you all a very merry Xmas time.

d 0 Points. No, an easy mistake to make but actually David Bowie has slightly high cheekbones and one pupil smaller than the other.

d 0 Points. What are you trying to do, reflect the viewership.

e as above.

b as above.

to educate after all.

13 a 10 Points. Absolutely old chap, a 'serious' machine. One is trying

d 0 Points. What are you, a complete dingbat?

c 10 Points. Well, you'll save yourself a lot of time and worry and it probably won't make much difference.

this as a sign of weakness.

b 0 Points. No, magazines never help one another and they will just take

seeming to have one. This should do it.

12 a 20 Points. Actually having an Exclusive is far less important than

d 0 Points. Only very boring mags have titles like this.

c 15 Points. As above for references - except it's a song - but too long.

old pop duo.

b 20 Points. Has to be a winner, irrelevant, irrelevant and mentions an

11 a 5 Points. Right idea but too enthusiastic.

b 10 Points. That's right.

one first).

(256K, dedicated graphics chip, 32-bit processor) or an ST (they make this

10 a 0 Points. The screen shot is almost always either from a coin-op

about that free launch?

c 5 Points. Not good. It might be good but, more to the point, what

PR man in your office all afternoon.

d 10 Points. Sounds wise but you may have to put up with an irritating

lunch. A winner.

c 20 Points. This is it, you don't have to agree to anything and you get

b 10 Points. You've obviously been in the business a while. . .

9 a 0 Points. No, Mega games are never called Lunar Blast.

devices and food are, however, another matter.

d 5 Points. Never works, journalists never take money for good reviews.

Free weekend in Paris, digital alarm clocks, small plastic promotional





## YOU RUN A COMPUTER MAGAZINE . . .

9) A PR man rings you up and says "Listen, I wouldn't lie to you and you know you can trust me, Lunar Blast is going to be bigger than Elite." Do You:

- a) Feel interested and offer him major coverage.
- b) Think he's lying and resolve not to trust him an inch.
- c) Suggest he arranges a lunch at Maxims for you both to discuss it further.
- d) Ask to see the game without committing yourself
- e) Laugh hysterically

10) On the back of the cassette box is a brilliant screen shot which makes Lunar Blast look astonishing. Just below it in very, very small type it says "screen shot may be of a different version of game". Is it, in fact, a picture of the Spectrum version?

- a) Yes
- b) No

11) You are stuck with a boring feature on Icons that has to go in the mag. What headline do you give it?

- a) Icon do that!
- b) Icon Tina Turner
- c) Icon see clearly now the rain has gone
- d) Icon front end interfaces

12) You feature a three page colour special on a brand new mega game which you believe you have as an exclusive. Unfortunately you

discover that your magazine's closest rival has, suffering from the same delusion, done the same thing. It comes out a day before you do. The PR people are laughing all the way to the bank. There is still some time. What do you do?

- a) Relax and just make sure the word EXCLUSIVE is even bigger on your front cover.
- b) Ring the other magazine and propose that since both of you have been deluded, both magazines drop the game.
- c) Do nothing
- d) Take out all reference to the word EXCLUSIVE in the piece.



## THE MEDIA . . .

13) You are producing a TV program for micro owners what do you feature?

- a) "an ordinary everyday BBC Micro"
- b) "an ordinary micro - like this BBC for instance"
- c) "your own micro - something like this BBC perhaps. ."
- d) The Spectrum

14) The feature pages of a colour supplement run (it being seasonal) a feature on computers. If there was a competition as well what would be the prize?

- a) A Vic20 complete with datacorder and software (Rat Maze 3K)
- b) A Dragon 32

- c) Ten copies of The Hobbit
  - d) Ten copies of StarGlider
- 15) You are an advertising copy writer (you thought up 'They're Explosive!' for Firework software) your current job is to prepare an ad for a game called Monster Mayhem. What does it say?
- a) It's a monster!
  - b) Monster value
  - c) A game that bites
  - d) Quite a good not too expensive value-for-money game

## PROFILE PERSONALITY

16) Study the picture: Who is the cheerful Christmas character?

- a) Sir Clive Sinclair
- b) Santa Claus
- c) Alan Sugar
- d) David Bowie



Who is this man?

0 Points. Don't be silly, the 'people doing serious things with their computer are about 1/2 a % of the market. They're often doing fine things but spend about £12.57

c 20 Points. Yep, this is the one. Take a look around the most successful software houses. . . we want licensing deals. . .

d 5 Points. Well, you are a realist anyway. . .

5 a 5 Points. Well, names ending in 'a always sound foreign. c.f. Transylvania but on this occasion. . .

b 0 Points. A dark land, all right, but lands in adventure games must have more than six letters.

c 10 Points. Always a good standby.

d 0 Points. Lacks a bit of threat don't you think?

6 a 10 Points. Always a good standby.

b 10 Points. Yes, household cleaning materials often provide good names for the incredibly unimaginative people who write adventure games. c 5 Points. As above except that names of mystic orbs in adventure games have to have at least four letters.

d ? Points. Nah, sounds cheap and shoddy instead of mystically powerful.

7 a 0 Points. The writer would quite like to see an adventure hero with this name, but can't advise that you take a chance.

b 0 Points. The people who play adventures avidly are youths between 10 and 20 and they don't want to be a woman (mostly).

c 10 Points. Always a good standby.

d 15 Points. OK if your hero is a bit dodgy and from the East End but for powerful adventurers wielding mighty battle swords in long forgotten magical lands, forget it.

8 a 0 Points. Surprisingly this seldom works, usually the editor will cringe a bit and then write all about it when you've gone away.

b 20 Points. Never fails. And don't forget, you don't have to be telling the truth.

c 10 Points. Varies, sometimes successful if the mag desperately needs some ads. Can backfire as some magazines take pride in attacking the products of people who are contributing substantially to their incomes.

aren't on TV or film, and you will never recoup your money and effort. The younger kids won't buy it because they don't grasp concepts that will get great reviews and the program will get to the bottom of the charts. 4 a 0 Points. No. Sorry, but listen carefully, this is a big mistake - you could even have a logo of an exploding sausage. Nifty eh?

d 20 Points. Good stuff. If you want to be particularly inventive you c 0 Points. Sounds like a medical condition

5 a 0 Points. No, imagine the advertising copy "they go off with a hffffrrrrpppp".

b 0 Points. Just wait for the little white letter.

3 a 0 Points. Yep, we'll tell you straight, except, of course, that since we only cover Sinclair material. . .

d 20 Points. Not a bad option, except that you probably won't end up buying anything at all. . .

c 5 Points. Not a bad option, except that you probably won't end up Spectrum and watch 'em squirm.

wrong. Try asking how to connect the cheapo printer the store sells to the not only biased in favour of the product they stock but are usually just plain b 10 Points. No, No, No. The people who work in the chain stores are believe the ads.

computer, the QL beat the IBM on spec etc etc. The first step is never to 2 a 0 Points. Oh come on, the Oric was described as a powerful d 10 Points. Nearly as good as b but more cowardly.

something?

c 0 Points. Hahahaha, what are you a government department or person.

b 20 Points. This has to be the only rational response of a sensible you were a programmer forget it. . .

only be appropriate if you were a journalist out to extract information. If 1 a 0 Points. You obviously have a lot to learn, this response would Bet it was easier than you thought for you to start thinking like a computer industry person. Here are the results with explanations:

## THE ANSWERS

**BUDGET**

£1.99  
£2.99

**REVIEW**

**K**ing Harold, my father, is heartless. Being cruel he terrorises his people into submission. Being completely nice, I'm incarcerated by my father in his keep.

This is obviously a budget game.

**King's Keep** could have been just another inferior **Spellbound** rip off. It has lots of rooms,

# KINGS' KEEP

objects to pick up, little menus that come down giving options and you jump around a lot. First impressions – very average graphics of the usual graphic adventure objects – were not favourable.

But then I tried to play it.

I haven't found a game quite as difficult to play as **King's Keep** in many, many moons.

The whole point of the game turns out to be not so much collect the objects and find out what to do with them as 'how on earth do I manage to jump,

change direction in mid-air and successful land on a suspended platform without overshooting'.

The first screen nearly had me weeping – my hands ached from gripping the joystick, I couldn't see how you could get out but, in the tradition of such things there was just one way – it involves simultaneously jumping and then a fraction later completely changing direction...

**King's Keep** will test your jump technique to the limit but it's also a menu-driven 'use the

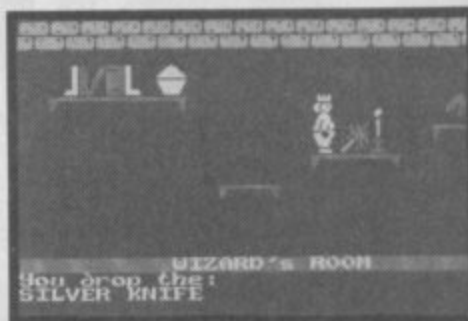

objects' game.

If you make it past the first two screens you'll start to find objects and meet curious people. Using the **Talk** option on the menu will make the character reveal some sort of information – an object they'd like or whatever. Some key areas are marked **F** for forbidden and crossing their threshold means instant death – unless you have the right object in your possession. All the backgrounds are plain – bricks or craggy bits mostly, objects are simple looking though there

# BLACK HAWK

**W**ould it frighten you to know that the world's most advanced airborne killer is a set of user defined graphic Us?

The UDGs pop up at the beginning of the game as **Black Hawk** is supposed to near the enemy coast line. Seconds later, as the first enemy helicopters appear from the top

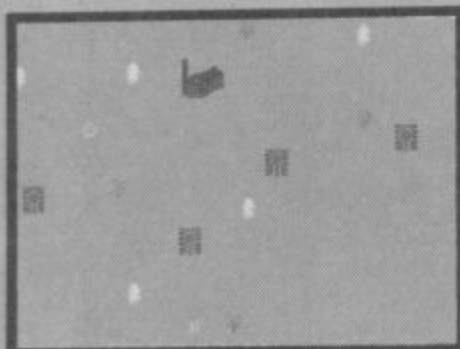

of the jerkily scrolling screen, the UDGs transform into the aircraft.

Once you're set up to play – all parts of the screen functioning as they should – you drift inland and destroy as many enemy guns, tanks and installations as you can using bullets and bombs.

The bullets are hardly visible, being white against blue or green backgrounds and the bombs have a mind of their own.

You get a percentage score for the number of direct hits you've made on ground-based installations and a points score for aircraft you knock out.

Many of the missions I found are almost unplayable because of the fire power of your opponents. Helicopters, gun implacements and tanks can fire diagonally at you while

## FACTS BOX

*This used to be a full price game! It was so hopeless then that even now it's out on budget it still can't cut it*

**BLACK HAWK**

Label: Sparklers

Price: £1.99

Memory: 48K/128K

Joystick: various

Reviewer:

*John Galt*



your puny gun in the nose of **Black Hawk**, can only fire forward.

The glossy cover promises a lot and fails to deliver

# PHANTOMAS

If I have to bounce my way around any more mansions looking for treasure and dodging obstacles I may go mad.

**Phantomas**, one of the first releases from Codemasters, a whole new software label, has finally sent me over the edge...

Screen after screen of funny (ie not funny) shaped objects hopping backwards and forwards, objects you need to collect that flash, things that must be jumped over. It goes on...

I can't stand many more cute characters either. This one like an orange with feet and a beret leaps around unpredictably, the way the jump button is pressed seemingly having little relationship to the height of the jump.

I tired too of backgrounds constructed of featureless bricks and steps that don't have any function because you can



jump over them.

There is, I suppose, something to be said for the sheer volume of material in the game, there are screens and screens of it. Three sections: one is a sort of junkyard of odd vehicles and rockets, the next is the palace and then there's the underground world.

Eighty different rooms it says on the front of the box, proudly. Well, different is stretching a point a bit. It's more a case that the silly sprites all come in various guises...

In an attempt to be generous this is a budget offering and it could be a good buy for Mr A J Twagget of 34 Elsmore Gardens, Rhyll (Mad Celt country) who has never heard of **Manic Miner**. Other computer owners are unlikely to need it

## FACTS BOX

*Another sub-Manic Miner budget bounce 'em up. No real original thought has been put into it but it's huge.*

**PHANTOMAS**

Label: Code Masters

Author: Enrigue Cervera

Price: £1.99

Memory: 48K/128K

Joysticks: various

Reviewer:

*Graham Taylor*

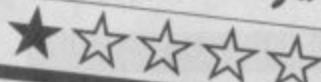

# ALIEN



**A**lien is in no way to be confused with **Aliens**, the new game from Electric Dreams. **Alien** first emerged from the depths of Argus Press way back in 1984. Based on the exploits of the crew of the ill-fated **Nostromo** spacecraft, the game, though was panned by some reviewers was generally quite well-liked.

It's now been re-released as a budget game. Obviously, Argus (pretending to be Bug-Byte) has in no way engineered the release date to co-incide with movie/game promotions of **Aliens**, but I dare say it's possible to conceive the odd sale being picked up this way.

The game is much happier as a budget title. At full price, the product promised too much. No matter how hard you try, it's very, very difficult to promote a computer game as being genuinely scary. The harder Argus tried, the more ridiculous things got: "Warning: Do not play this in the dark."

In fact, despite some ropery abbreviations allowing words to fit on the screen (Incineratr) and some iffy graphics, it isn't too bad. You take the role of a member of the crew, Lambert,

are some nice plants here and there. . . No prizes for graphics though.

If you regard **King's Keep** as the ultimate jumping challenge you'll love it.

One of the best budget titles from Firebird for a long time but definitely not for novices ■

### FACTS BOX

*Visually unexciting but fiendishly difficult mixture of Manic Miner and Spellbound. Really dev-i-ous - a real challenge*

#### KING'S KEEP

Label: Firebird  
Author: Ian Wright  
Price: £1.99  
Memory: 48K/128K  
Joysticks: Kempston

Reviewer: *Graham Taylor*



# TERRA COGNITA

**N**ow this is what I like. Terra Cognita is the perfect budget game - a simple idea nicely presented.

Mind you it's not suprising this is a very slick looking game - it's by NonTerraqueous programmer Stephen Curtis.

What it is, if it must be compared to anything, is a two-colour version of Lightforce mixed with elements of Uridium - not quite as good, maybe, but at £1.99.

Do you need a plot for this sort of thing? OK, then you are trying to pilot your ship over 100 smoothly scrolling screens to meet up with a mothership. Getting over those 100 screens will take a long time.

There are, of course, vast numbers of alien spaceships which come wizzing across the screen. At first they are easy to polish off but gradually things start to get tricky. That's the Lightforce bit - that and the style of the graphics.

The Uridium part comes with the fact that there are vast areas of block - like buildings on the planet's surface which you have to steer your way around. Gradually that becomes more and more difficult - sometimes it's almost (but not quite) impossible to get from one side of the screen to the other in time. . .

There are other features too, refuel squares, extra squares and, perhaps worst of all the

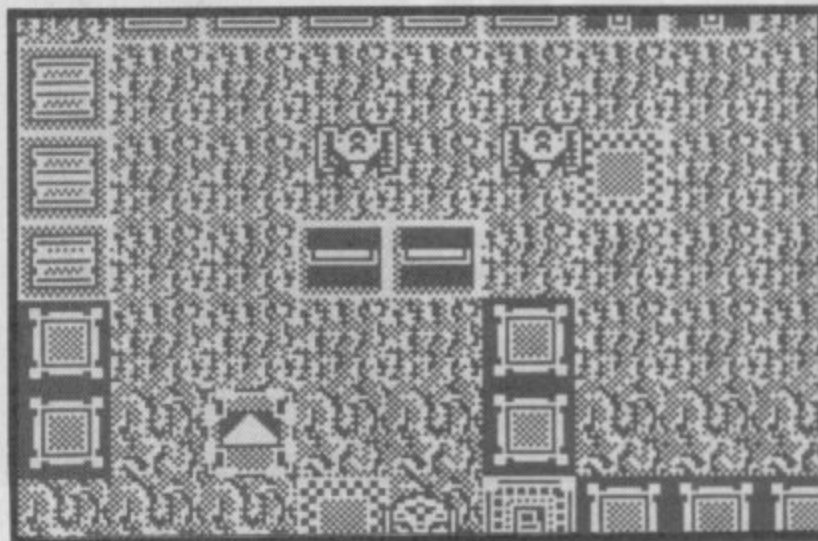

### FACTS BOX

*Superb arcade game with near Lightforce quality graphics and a lot of good ideas. A real test of your joystick control*

#### TERRA COGNITA

Label: Code Masters  
Author: Stephen Curtis  
Price: £1.99  
Memory: 48K/128K  
Joysticks: various

Reviewer: *Graham Taylor*



time warp squares which send you right back to the beginning of the game. There are squares to slow you, squares which speed you up and you need to work out when to use both to get through some sections of the game.

The mix of extremely fast arcade action with the strong element of thought and planning make for a stunning game.

Terra Cognita is more entertaining and better programmed than most games at full price, yet it's a budget offering.

And it's by far the best of the new Spectrum releases from Code Masters ■

Kane, Ash, Dallas, Parker, Ripley or Brett, in a desperate bid to rescue your spaceship from the altogether beastly alien.

As the game goes on, messages will pop up on the screen, telling you that something exciting has just happened elsewhere (Ripley sees Jones the cat).

The basic idea is to track the alien through the ducts, and blow it away by whatever means are most efficient. Blowing up the ship is quite a safe bet, but everyone gets killed, and since you die you lose a few points on the competence rating.

Alien is claimed to feature a unique personality control system. What this means is, in fact, that other characters will get a bit stropky if you leave them to defend themselves. The more upset they get, the less likely they are to agree to one of your more lame-brained ideas ■

### FACTS BOX

*Alien is a reasonable game, a good budget bet, and is more suspense-orientated - like the first film*

#### ALIEN

Label: Bug-Byte  
Author: Paul Clansy  
Price: £2.99  
Memory: 48K/128K  
Joystick: various

Reviewer: *Jim Douglas*



# HERCULES

**H**ercules looks absolutely awful. It isn't. Quite. I wouldn't go as far as some other magazines and say that Hercules is a great game that just looks like a terrible one but certainly it has some unusual features.

It looks like a platforms and ladders game, the plot is based on the twelve labours of Hercules as divided over fifty screens. For those who don't know about the twelve labours all reduced to running and jumping around and dodging funny objects. But that's not all.

What makes Hercules something a little more than a runny jumpy game with terrible graphics is the overall structure of each screen. It isn't merely a matter of jumping this, dodging that, taking this route or whatever, you find that over time things happen - previously



safe platforms turn into fire - other platforms look safe but turn to fire the moment you step on them, sometimes you don't even know where the platforms are. . . This adds a different dimension to the game and gets it a few brownie points (a star's worth I guess).

I would still say that a) the graphics on Hercules are unspeakably bad b) some of the 'will it burst into flames?' element' is simply unfair at least first time around - no amount of skill, dexterity or

### FACTS BOX

*Not quite a boring platform and ladders game with terrible graphics. Some neat twists earn it a few extra points*

#### HERCULES

Label: Alpha Omega  
Author: In house  
Price: £1.99  
Memory: 48K/128K  
Joystick: various

Reviewer: *Graham Taylor*



judgement will help you solve it and it's just luck.

I wouldn't go so far as to recommend this one even at a budget price but if you are an addict of the platforms and ladders genre and fancy something a bit unusual this could be of interest ■

ARCADE



REVIEW

Well, I dunno. What has Mikro Gen been doing other than redesigning its logo?

Frostbite is part of the answer but it's hardly a mammoth (snow joke, geddit?) offering.

I don't know how many games this reminds me of, Manic Miner for one, Starstrike for another, Underwulde (I could go on). It's getting through the caverns time again, judging the timing to get you past endless obstacles that drip, bounce or otherwise travel into you. You can fire at some of

# FROSTBITE



them, others need specific weapons scattered around. There is a lot of jumping in this game, both unassisted and with

the aid of various bounce platforms strategically placed around the caverns.

You are a curious object that



looks and moves just like a slinky (remember them?) – a sort of spring that tumbles over and over and thereby moves. The way you move is unusual and consequently some of the strategies involved in the game are a little different. The combination of jumping and moving, for example, takes a while to work out.

The object is to get out, simple, really. Useful objects include various coloured sweets that control things like jump height and speed and what look like air-to-air missiles. I'm all for high tech violence personally.

Where does that title come from? Not a clue. Although clearly the caverns are supposed to look icy there is no other arctic, polar, or otherwise nippy feature in the game. Oh well.

The sprites are big. That's good but, though some care has been taken with attributes, Mikro-Gen remains true to its Wally traditions and objects change colour with gleeful abandon.

As a game it looks OK. There are some impressive monsters in some of the caves (although mostly the big ones don't do anything at all) and the problems (timing the jumps) are difficult but not quite impossible which I guess is about right.

Nothing special. There isn't any astounding programming or stunningly original ideas to be found – but fun to play anyway.

## HIGHLANDER

There can be only one' says the cassette inlay but the game of

Highlander, sadly just ain't it.

It's all been loosely based around the patchy movie in which Conner MacCleod has to kill all his brother immortals to win a mysterious prize – which in the film turns out to be fertility. And the mode of execution? Nothing less than blood-squirting decapitation.

In the three-part game you train as an expert Samuri swords player before you can despatch your opponent and take your just rewards. There are three game Loads the difference being a new background is loaded as a Screens and a new opponent.

Only the top third of the backdrop contains an illustration and the rest of the screen is kept black to avoid colour clash with the main figures which one big (about half-Dark Sceptre size) and well

animated.

Your first opponent is Ramirez. He's a Spanish gay blade and, as your teacher, he knows he's unlikely to survive.

### FACTS BOX

No prizes here. Ocean probably paid big bucks for the license and has ended up with a golden turkey

### HIGHLANDER

Label: Ocean  
Author: Canvas  
Price: £7.95  
Memory: 48K/128K  
Joystick: various

Reviewer: John Galt



You get a sword-play hint sheet but it turns out to be next to useless once you start to play. The basic move is duck, joystick down, and perhaps advance, joystick left.

Highlander is all about energy and, in the film, when you win a fight you take on the life force of the vanquished. It's not a fact which has been assimilated by the programmers. If you kill your quarry his blood – and little else – spurts all over you after his head's toll off – screen with a unique splatter sound effect which can only be found on the Spectrum.

You can tell you're losing when MacCleod sits down on the job and refuses to get up. Shortly after your energy slips into the red sector – not good.

Kill Ramirez with a dazzling display of attack, timing and position and your move on to the next background, in modern day New York. He's a shady character called Fizir. Here the game and film part company. MacCleod does battle a Saracen at the beginning of the film but his name's Fasil, not Fizir.

Yet more attacking play and you're through to the final conflict between you and the evilsome Kurgen.

It was here I was defeated. The third battle is very difficult to win, and you'd think the challenge would make a good game. You'd be wrong. The three parts to the game are virtually identical and I was losing interest long before I got to the third part.

And there's almost no technique or finesse required in the fighting. Relentlessly slam the joystick and keep on till you win. Let up for a second and you're dead. So's the game ■



### FACTS BOX

Moderately entertaining 'negotiate the caverns' game with some original features. Old ideas, but neatly done

### FROSTBITE

Label: Mikro Gen  
Author: in-house  
Price: £9.95  
Memory: 48K/128K  
Joystick: various

Reviewer: Graham Taylor



NOW AVAILABLE – the official Spectrum Upgrade!

# Turn your Spectrum into a Spectrum + for just £23

Makes a great Christmas present

ORDER NOW!



- Professional full-size keyboard – includes 17 extra keys.
- Responsive typewriter-style action.
- Accepts all current Spectrum software and peripherals.

+ £1.50 p + p

ACCESS WELCOME

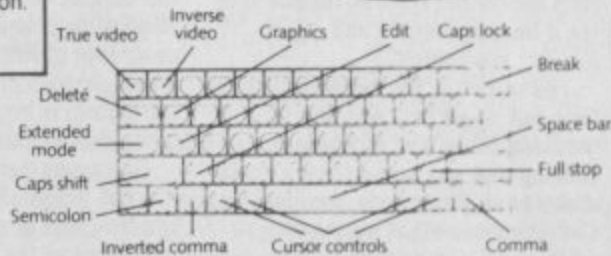

**The official Spectrum Upgrade.** Naturally your upgraded computer will accept all the peripherals in your Sinclair system - Interface 1, Microdrives and so on - as well as all Spectrum software. Just as important, new Spectrum software and peripherals will be designed with the Spectrum + in mind. So the Sinclair upgrade adds **stylish looks, new capabilities** ... and new potential for the future.

**Here's some exciting news for Spectrum owners ...**

the official Spectrum Upgrade Kit. The Upgrade has everything you need to turn your Spectrum into the stylish new Spectrum +. You don't even need an understanding of electronics, just the ability to solder a few wires together! The leaflet in the kit gives clear, step by step instructions. If you're not sure about doing it yourself, don't worry. Simply return your 48K Spectrum to us and for **£29.95 + £1.50 p + p** we'll upgrade it for you.

**The bigger, better Spectrum keyboard**

The Spectrum + measures 12 1/2" x 6". It has a large typewriter-style keyboard, with hard, moulded keys. You'll find the new keyboard has a smooth, positive action - ideal for touch-typing, word processing, simulation programs, and extended programming sessions. Two retractable legs give a **perfect typing position**. There are 58 keys in all, including 17 new keys. Programmers will be pleased to see dedicated punctuation keys, a space bar, and separate shift keys for graphics and extended modes. And a reset button allows you to clear a program from your computer's memory without disconnecting the power supply.

**HOW TO ORDER BY MAIL**

1. If you require us to do the upgrade for you please send **£29.95 + £1.50 p + p**. Total **£31.45**.
2. Should you require the do-it-yourself kit just send **£23.00 + £1.50 p + p**. Total **£24.50**.
3. If you require your Spectrum to be repaired and upgraded to a Spectrum Plus we have a special offer price of just **£50.00** complete.

Orders can be placed by using your Access Card on the numbers below.

**VideoVault** Ltd.

Upgrade Dept. 140 High Street West, Glossop, Derbyshire SK13 8HJ  
Tel: (04574) 66555/67761 & Manchester 061-236 0376

© Copyright Videovault Ltd No 689032

## ROMANTIC ROBOT present

**NO.1 MULTIPURPOSE INTERFACE FOR 48K & 128K SPECTRUM**

**Multiface ONE** <sup>TM</sup> **Version 48**

*New again!* **NEW ENHANCED VERSION AT THE OLD PRICE OF £39.95!**  
WITH MORE HARDWARE & SOFTWARE THAN EVER BEFORE AND  
WITH MORE FEATURES THAN YOU FIND ON ANY OTHER INTERFACE

- \* Internal 8K ROM & 8K RAM enable FULLY AUTOMATIC saving of anything, anytime onto MICRODRIVES, WAFADRIVES, BETA, OPUS, KEMPSTON and TAPE with extra 8K at user's disposal and with an extensive MULTI TOOLKIT to study/modify/develop/programs.
- \* Plus a joystick interface (IN31, i.e. Kempston compatible) and a switch to make MULTIFACE ONE INVISIBLE.
- \* MULTIFACE ONE does not take any part of Spectrum RAM and does not need any additional software. Just push a button to freeze a program, save it and restart from the same point next time.
- \* MULTI TOOLKIT facilities allow to PEEK/POKE the entire 56K, show blocks of RAM with on-screen editing and decimal hex or ASCII display, enable programmable jumps to anywhere within 56K, etc.
- \* Menu-driven with prompts and one-touch commands: 1) Push button 2) Select function: exit/return/save/tool/copy/jump 3) Input name 4) Save to: tape/cartridge/wafer/opus/beta/kempston (If using Kempston please specify when ordering)
- \* Extremely powerful and efficient compressing for fast re-loading & using minimal room on cartridges, tapes, wafers, disks.
- \* Option to SAVE a screen only \* COPY screen to printer (for printers interfaces accepting COPY command)
- \* Through extension bus for connecting other peripherals \* User-friendly, fully error-trapped, guaranteed, *simply magic*.
- \* Programs saved with MULTIFACE can RUN independently \* 128K Spectrum usable in 48K mode only on Version 48

Expand your Spectrum to 56K and stretch its capabilities even further with

**Multiface ONE ESSENTIAL SPECTRUM COMPANION**

**SELENE plus ANACHRONISM**

A fantastic twin bumper pack of sci-fi adventures for travellers in time - both very intriguing and exciting, complex and detailed, funny and witty. Travel in time backwards and forwards as you never did before - certainly not in any adventure yet...

**STEEPLEJACK**

A ghost town stands in the way of motorway M07 and only STEEPLJACK can demolish it with his drill and oversized pair of lead boots in this highly fresh, original, and stylish arcade game. STEEPLJACK must be very fast, crafty, alert and strong - there is a whole army of creatures and features one can only find in a ghost town, so much to do, so little time left...

**NEVER MIND THE NASTIES**

NMTH contains the same unique humour and addictivity as its older brother, the hit game WRIGGLER. The action takes place in a weird and bizzare world full of mutants and monsters, dungeons and sewers, conveyor belts and express elevators, deserts and pyramids, trampolines and space stations, a world that must be explored and fought through to prevent a total annihilation of human race.

**MUSIC TYPEWRITER**

Complete Spectrum music system for writing, editing, playing, printing & storing music with real notation graphics.

**TRANS-EXPRESS**

The software way of transferring Spectrum software. 4 utilities for m-drive, 2 for wafadrive, 2 for Opus Discovery.

**TOP SOFTWARE AT BOTTOM PRICE**

I enclose a cheque/PO for £..... (UK & Europe please add £1 overseas £2) Please send

or debit my No  SELENE & ANACHRONISM £ 9.95  STEEPLJACK £ 4.95

Name..... Card expiry..... NEVER MIND... Amstrad £ 9.95  or disk version £ 14.95

Address..... MUSIC TYPEWRITER £ 7.95  WRIGGLER Spectrum £ 2.95

TRANS-EXPRESS cartridge  disk  wafer  £ 11.95

MULTIFACE ONE £39.95

## AIR TRAFFIC CONTROL

Take over control of two of the world's major airports; London Heathrow and Schiphol Amsterdam. The screen display may look docile but you're in the hot seat from which the landing instructions for a host of jumbos and light aircraft are issued.

You're not in the pilots seat this time but make just one slip in stacking those aircraft before landing and you could have a major disaster on your hands. Fortunately, the game has eight play options which help you to train in your new job.

The most simple options include



## TT RACER

Here's a real meaty motorbike simulation for addicts, which has more features than the budget Full Throttle but is more difficult to play.

Again, you ride a Grand Prix bike but there are 12 international circuits and 15 other riders with whom you must compete. Your machine has throttle, clutch, gear and brake features all of which need constant attention as you wheel around the bends of circuits such as Silverstone, Hockenheim and Anderstorp. Just as the bike performs to life-like standards the straights and bends of each course have been accurately plotted by the author.



You have a pit stop on each course where your crew can fiddle with your bikes hardware and power. The gear ratios, steering speed and tyre-type are among the bike features which you can change.

The opposition can be controlled by the computer or by your friends, if they own a Spectrum and Interface One. The program will use the network facility of interface one to allow you to control each bike on the circuit through several Spectrums.

TT Racer is by far the best of the bike racing games.

Label: *Digital Integration* Price: £9.95 Memory: 48K/128K Joystick: Various

Basic Vectoring where you must guide a selection of aircraft onto your strip, while the most difficult include emergency landings and stacking. If none of those seem easy the author, who also wrote Nightflite II and is an air traffic controller at Heathrow, has included a demonstration which shows how the screen is layed out and the types of command you need to know.

Like many computer simulations it's not graphically impressive but it's the most powerful and authentic simulator of the lot.

Label: *Hewson* Price: £9.95 Memory: 48K/128K

## Fighter Pilot

Regarded by many as the ultimate Spectrum flight simulator and, indeed, it has a host of impressive features.

The aircraft is modelled on the US Airforce's F15 fighter bomber which you must take through an air to air battle simulation. Graphics are wireframe - like those of StarGlider - but the lack of detail on enemy aircraft and geographic features is made up for in a corresponding smoothness and speed in the graphic movement.

It's not all battle, however. The cassette inlay gives instructions for performing aerobatics. Diagrams show how your F15 should react when you move the controls in a certain way.

Fighter Pilot scores for speed over Hewson's Nightflite II and just beats Psion's Flight Simulator for entertainment value. It was written by Dave Marshall who has designed software for large scale flight simulators used by companies such as British Aerospace and Britannia Airway's for their training programmes.

Label: *Digital Integration* Price: £7.95 Memory: 48K/128K Joystick: Various

## TOMAHAWK

The most complex and satisfying helicopter simulation on the Spectrum. You take control of a US Airforce Apache helicopter. It's a modern model, designed to fly low through a 3D landscape of trees, mountains, high buildings and electricity pylons.

The complex console display has been copied straight from the real McCoy so, you'll need to do all the

## CAN THIS BE REAL?

Fly an aircraft, race around the world's most dangerous Grand Prix circuits or take a steam locomotive from London to Brighton. Just as your Spectrum can take you into the depths of space to zap aliens so it can simulate most audio visual real-life events you can mention. This month **SU** straps itself into the world of Spectrum simulators. Here's our choices:

## STRIKE FORCE HARRIER

The Hawker Harrier jump jet was brought into action during the Falklands war and it is on this island with its extremes of landscape and treacherous climate that Strike Force Harrier is set.

Your objective is to destroy the enemy base, situated 250 miles over land. First you've got to get there and flying a Harrier is no easy job. You'll need to take the aircraft up many times before you get the hang of the instrument panels and the controls which were designed for contortionist but can be user-defined.

Once you've got the hang of your Harrier you can take off over the mountainous terrain, some of which is snow covered. The multi-purpose

window at the bottom left of the screen will tell you if you're in mechanical trouble or you're about to crash, the FOFTRAC will track enemy aircraft but you're on your own when it comes to finding the enemy base. There's no full blown map for you to swat up so, like a real pilot, you'll have to rely on your flying skills.

The excellent flight manual takes you through the hardware details of your Harrier, how to get it up in the air, how it performs once it's up there and how to perform the various defensive and attacking manoeuvres to best effect. There's even a guide to the evasion of SAM and AAM missile attacks.

Harrier is simply the best war zone simulation I have seen.

Label: *Mirrorsoft* Price: £9.95 Memory: 48K/128K Joystick: Various



swatting up required of a trainee pilot. You are, of course, at war but have a complex weapons' system at your disposal to destroy the tanks and missiles which attempt to knock you from the skies.

The Spectrum version of the helicopter has eight Hellfire missiles, two rocket pods and a cannon, compared to the real Apache's 16 rockets 19-round pods and cannon. However, a helipad will always be at hand for you to stock up with more. Rockets can be aimed manually or targetted by the computers and you've also got infra-

red camera equipment to help track targets during night.

The aim is to take out as many of the enemy's positions as possible but just flying the copter is a fascinating experience.

Label: *Digital Integration* Price: £9.95 Memory: 48K/128K Joystick: Various

**SIMULATIONS  
SURVEY**

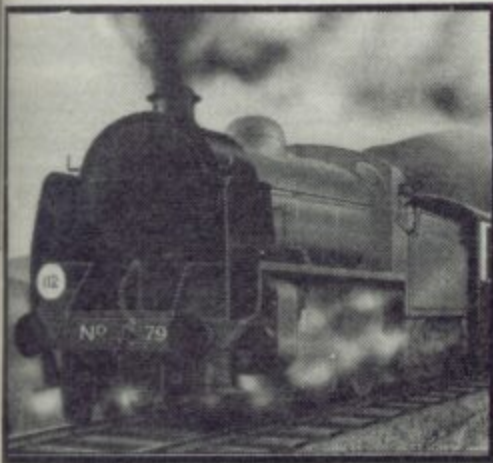

**SOUTHERN BELLE**

The Victoria to Brighton line has always been a firm favourite with steam railway enthusiasts and, at the beginning of '86, Hewson capitalised on a large minority's infatuation with trains with the launch of Southern Belle

You take the dual roles of Driver and fireman on the train through the 50 mile run and six levels of legitimate play.

Pressing the *Enter* key gives you that famous high speed run through an authentically depicted track layout. All the major features and atmosphere of the country side and small village stations are depicted. The bridges are actually drawn and even the sharp turns are realistic.

Each of the six main levels has a different schedule. Easy schedules include speed limits with stops at some stations - making it difficult to keep to your time table - while the higher level schedules stop the train at every stop and pose built-in problems such as making a record-breaking run.

Your trips to Brighton are



evaluated by the computer and a score totted up at the end of the journey which takes account time keeping at stations, speed and whether you've kept the steam in good nick. You can do all the usual things, like blowing the whistle, stoking the fire and slamming on the brakes but you should watch out for the error messages such as Unsafe Reversing or Train Derailed. Think of the passengers.

Okay, so you're not exactly in a joystick controlled driving seat for this one, but this stoking and shunting simulation will take you back to the good old days.

Label: Hewson Price: £7.95 Memory: 48K/128K

★ **COMPETITION** ★

**Win Ocean's Top Gun and a chance to fly into the Danger Zone**

**W**in an all expenses paid visit to one of Britain's biggest flight simulator complexes, in Hertfordshire. It's normally closed to the public but British Aerospace will let one lucky

**SU** reader into the simulator cockpit. You'll believe a computer can fly.

Fifty second prize winners will receive a copy of Ocean's Top Gun combat simulator together with a colour film poster from Paramount, while 25 third prize winners will get a copy of the film's chart topping sound track.

Have you got what it takes to be a Top Gun? With 70+ prizes you've gotta be in with a chance.

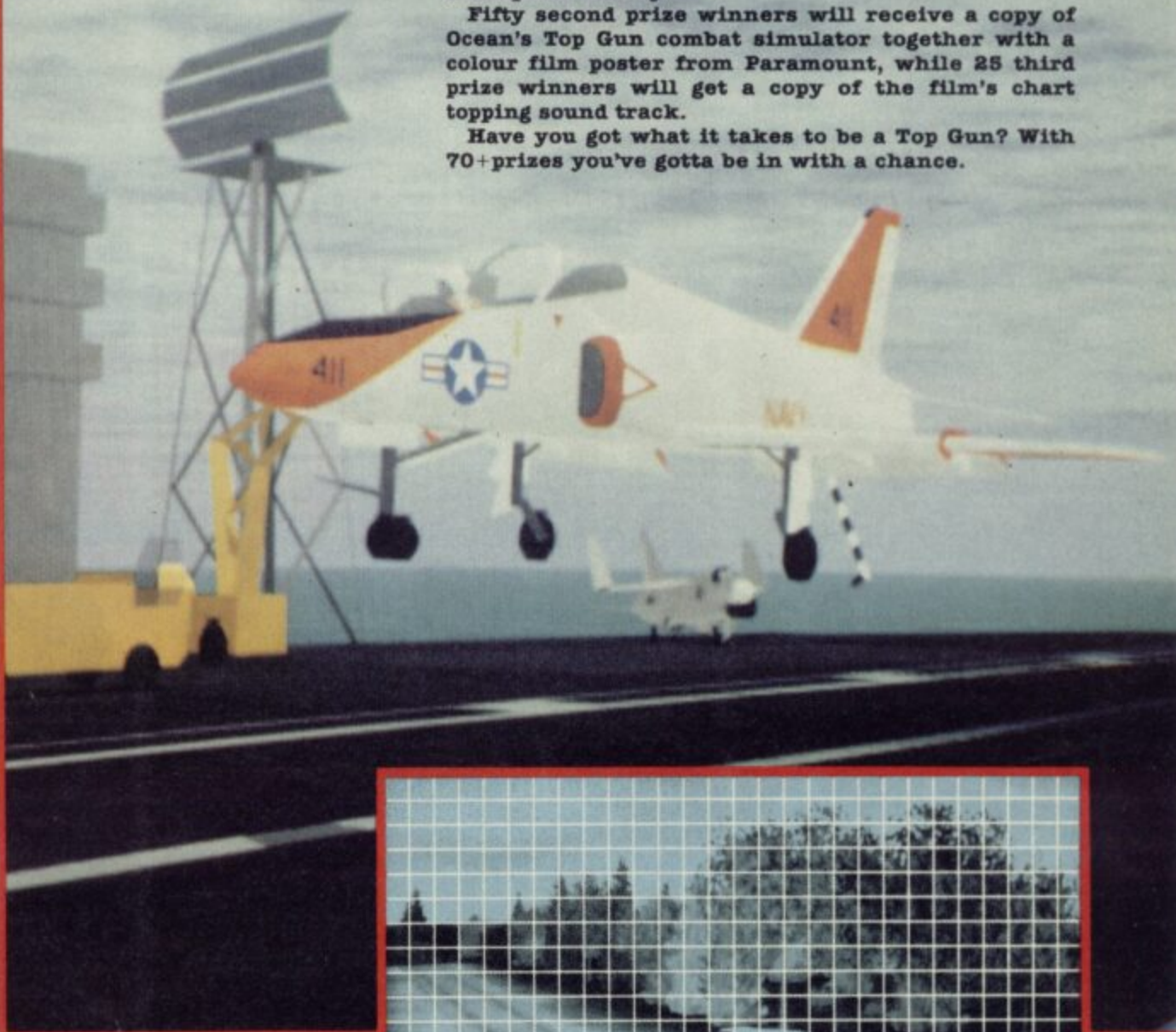

**Competition**

So here's what you have to do:

Remember those spot the ball competitions in the newspapers where you had to guess from the faces of the players where the ball was? This is like that. Take a look at this action shot carefully retouched so that something is missing i.e. the fighter that's about to land. Where's it gone? Put a tick in the grid square where you think the enemy ought to be. If you get it right you go into the large brown sack from which the winners will be drawn

Cut out this coupon, complete with the picture above with your tick on it and send it to: Top Gun Compo, Sinclair User, 30-32 Farringdon Lane, London, EC1R 3AU. Closing date for the competition is February 9 1987. High flyers from EMAP, British Aerospace or Ocean need not apply.

Name .....  
Address .....  
.....  
.....

# DURELL BIG 4

4 Smash hit games in one pack – Only £9.95  
available on Spectrum, Commodore 64 & Amstrad

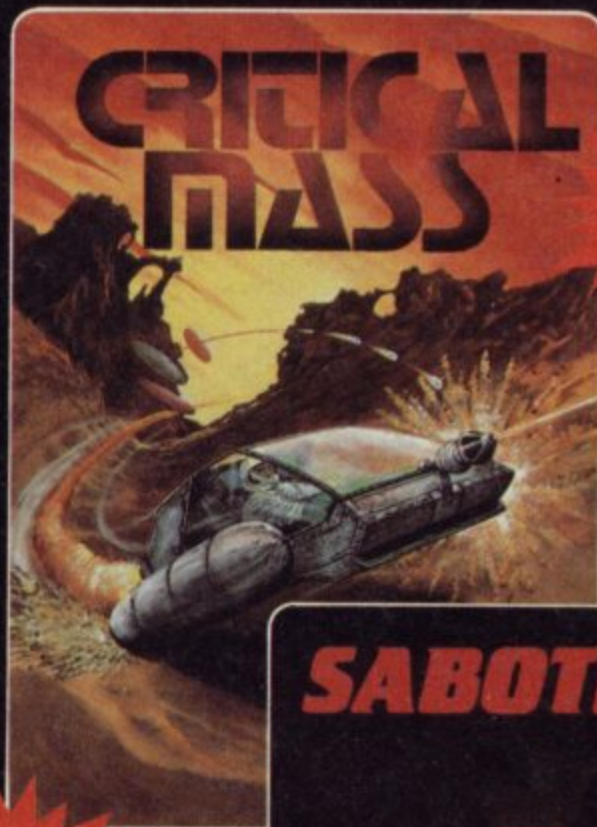
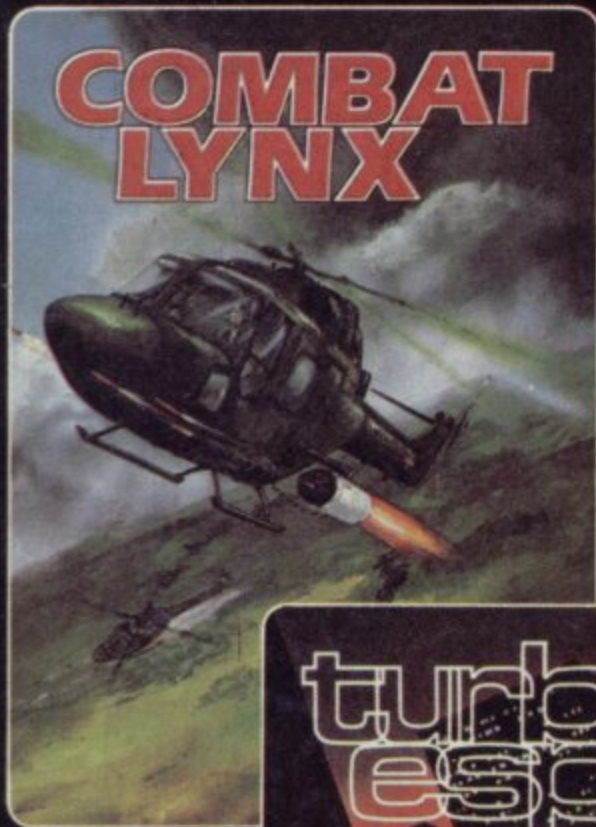

NEW ON  
AMSTRAD

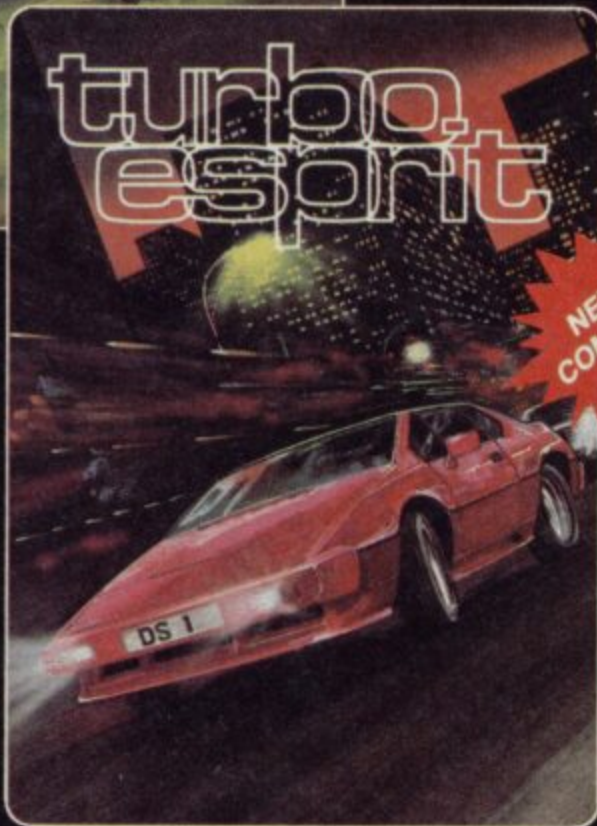

NEW ON  
COMMODORE

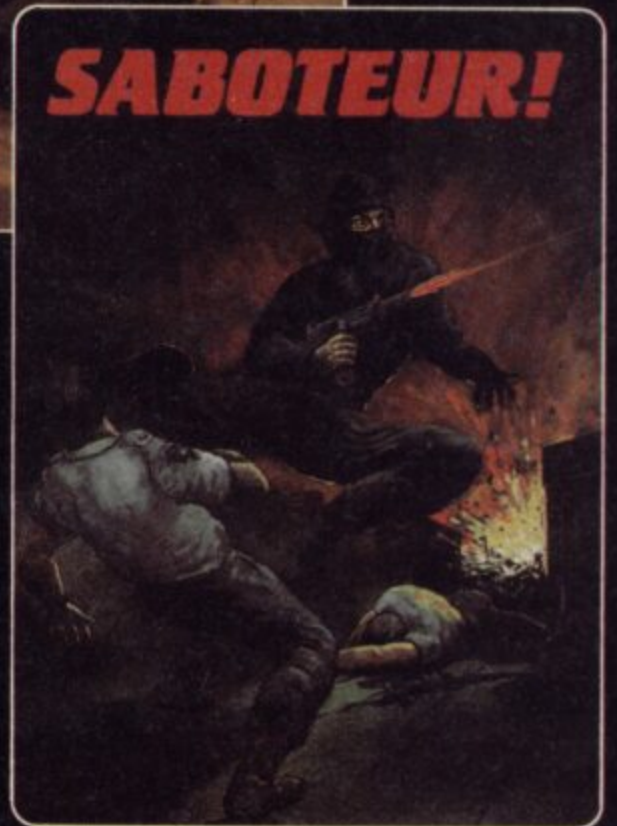

DURELL sales dept.,  
Castle Lodge, Castle Green, Taunton, Somerset, TA1 4AB, England  
Telephone (0823) 54489 & 54029

**software getting harder . . . .**



# THANATOS

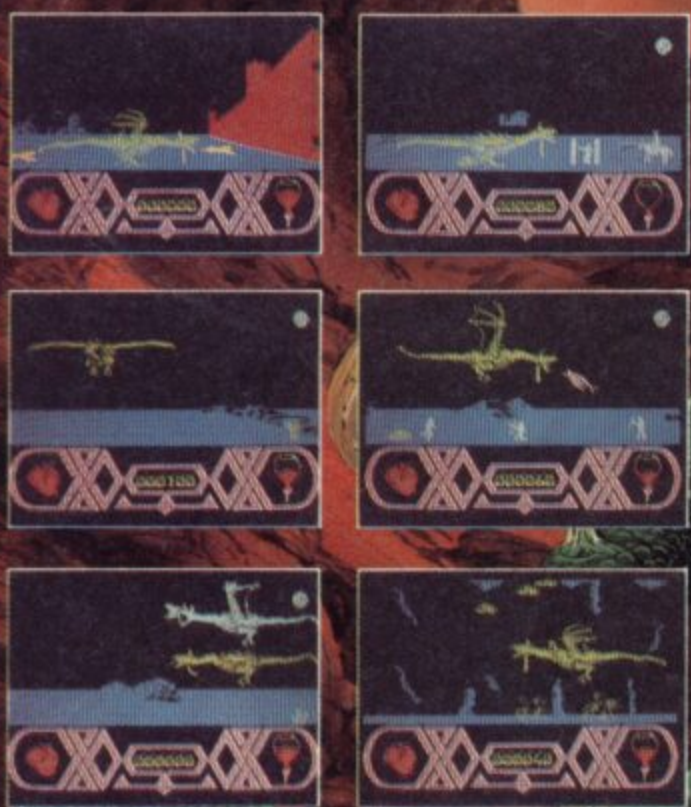

Spectrum in October, Amstrad in November, Commodore 64 in December.

All £9.95

## DURELL

*software getting harder . . .*

Sales dept.,  
Castle Lodge, Castle Green,  
Taunton, Somerset TA1 4AB  
England Telephone (0823) 54489 & 54029

# DONKEY KONG™

from Nintendo™

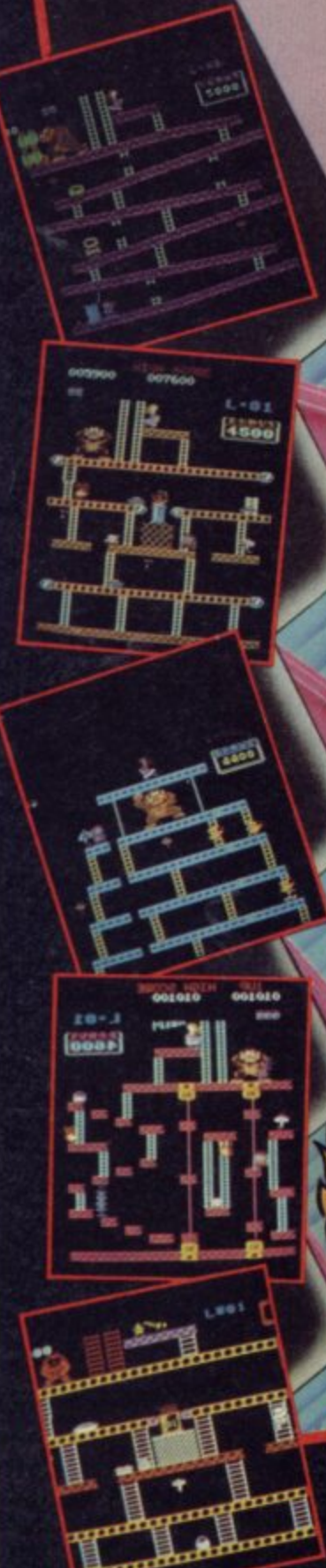
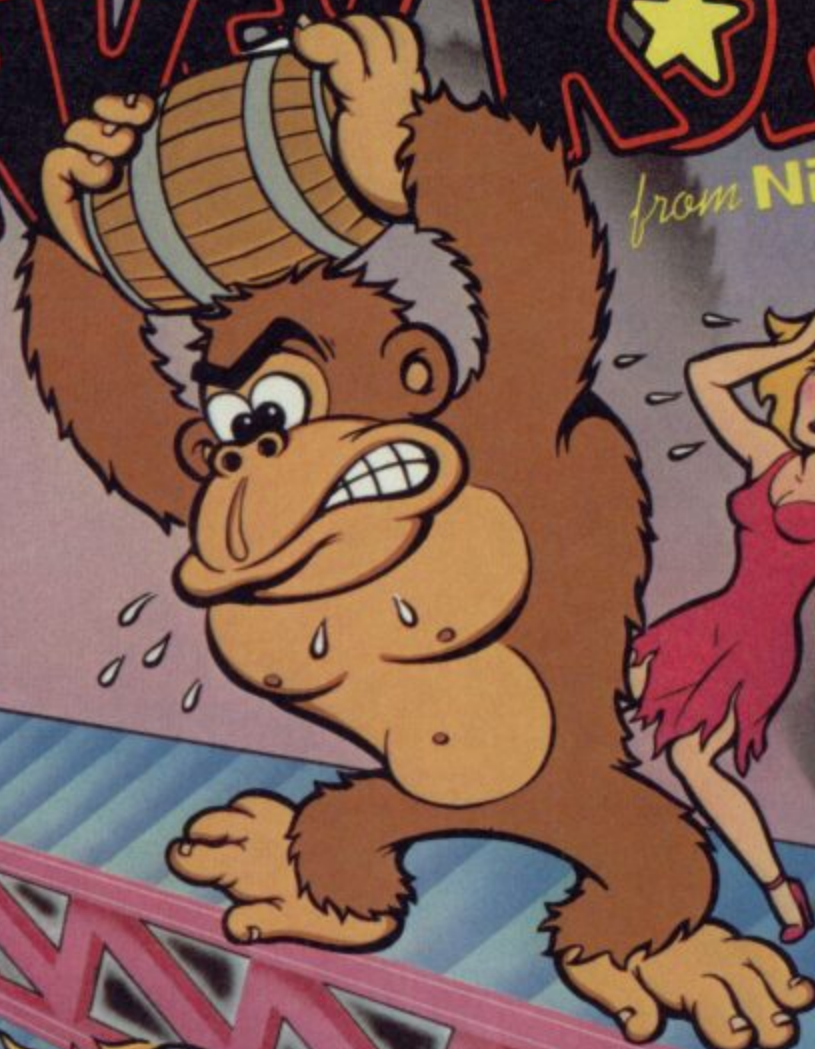

*Cabanga*

**Classic arcade action with this all time coin-op favourite.**

Outwit the giant gorilla and save the girl in this historic rescue. Mario is armed with only his wits and his trusty hammer as he climbs the girders in down town New York. Multiple screens and fast moving action, dodge boards, fireballs and much much more. In the final screen remove the rivets in the structure to finally bring the beast crashing down. Screen shots taken from various computer formats.

**SPECTRUM COMMODORE**  
**7.95 8.95**  
**EACH EACH**  
**SPECTRUM AMSTRAD**



Ocean Software Limited 6 Central Street Manchester M2 5NS.  
 Telephone: 061 832 6633 Telex: 669977

© 1981 Nintendo. TM indicates Trademark of Nintendo, licensed by Ocean Software Limited, authorised user. All Rights Reserved.

# THEY STOLE A MILLION

ARCADE



set in a square in the road. That's your first team member. Using the system's icons, at the bottom of the screen, move Number 1 through his paces. Then do the same for No 2, No3 and so on. The general plan of action is the same for most of the robberys: get into the premises without tripping alarms, smash the cases, bust into the safe, grab the loot and scarpers. Every action is timed and the computer calculates the amount of time your plan would take. You can't slow down this digital clock but you can add seconds to it so your team pauses, thinks, and doesn't make any mistakes in a rush. The clock timing makes your plan more difficult because each team member must perform their tasks without getting in each other's ways. Take a note of when Detonator D'Arcy does his stuff or Skeleton Joe could get written off if he's in the wrong place at the wrong time.

Yet, a little more attention to on-screen detail and some tightening of the gameplay and **They Stole a Million** could have switched from interesting-but-unsatisfying to brilliant. A big pity.

## FACTS BOX

*Highly original idea spoilt. Monotony at the planning stage turns into tedium at the denouement. A pity*

## THEY STOLE A MILLION

Label: Ariolasoft  
Price: £8.95  
Memory: 48K/128K

Reviewer: *John Galbot*



on the front door – you'll need the locksmith – whole inside the safe and three display cases are wired. So, you'll need at least a three – strong team.

There's quite a choice of petty crooks on offer for your team. There are safe breakers, people who have turned their legit electrical training to more lucrative ends, and wheelmen who are hooked in the fast lane. OK. To make your plan work you'll need a balanced team made up of three or four villains.

Once you've picked your target and team, now's the chance to develop your time plan. Load in the second part of the program and the exterior of the target premises is shown. It's a simple map just a few lines describing buildings and pavement and a number one,

Ever wondered how they'd turn a caper movie into a game? **They Stole a Million** from Ariolasoft is how.

**They Stole a Million**, on the face of it, is a highly original strategy game in two parts: Part 1 is all about planning, Part 2 is the perps (perpetrators) in action against your clock.

So far so good. The snag is, despite its obvious originality, the game lacks pace. In fact it's a bit boring. Selecting icons from the menu and setting the timings for each move of each of your team is difficult, sure. But after a while it's also tediously repetitive.

And Part 2 isn't really any

more satisfactory. It cried out for really good graphics and fast action as the heist is carried out, but it has none of these things. I fear **They Stole a Million** will have all but the most committed strategy game player yawning after only a few heists.

You're a small scale thief, despite your ambitions to be a big Boss, so you should pick your target carefully. There are banks to rob and jewellery stores to smash but, when you're a beginner, go for easy pickings such as the coin shop. Each target also has a different security system. For instance, the coin shop has a sturdy lock

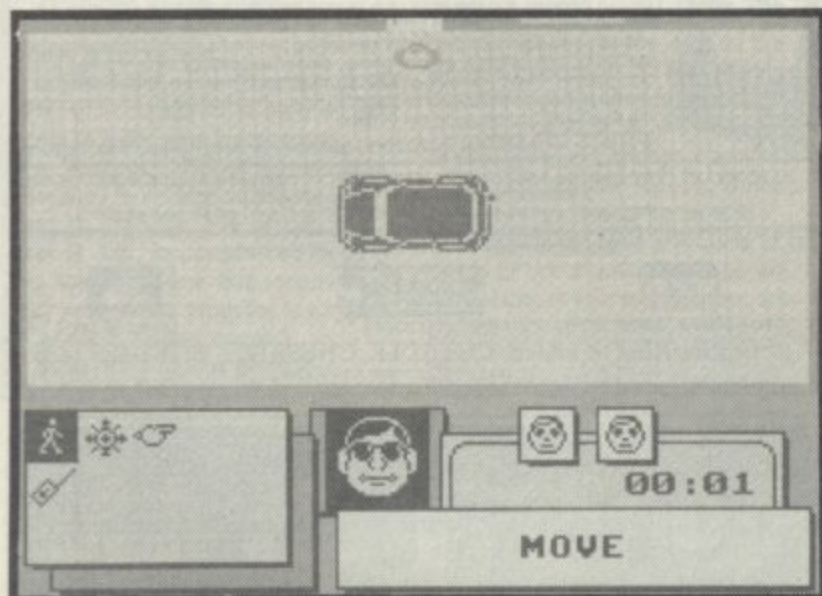

**"Well crucial, man"** is how Durell Software describes **Fat Worm Blows a Sparky**.

You, as the worm in the title travel the inside of a Spectrum, collecting spindles and avoiding creepers, sputniks and sparkies.

## FACTS BOX

*An original looking game, with a dubious storyline and an inflated price. Could have made a good budget title*

## FAT WORM BLOWS A SPARKY

Label: Durell  
Price: £9.95  
Joystick: Various  
Memory: 48K/128K

Reviewer: *Jim Douglas*



# FAT WORM BLOWS A SPARKY

The screen has a 'status' display in the lower portion, giving you an indication of how much energy you have left, score, hi-score etc. The remainder of your screen shows the world in which Wormie can travel. It's a plan view, pretending to be three-dimensional.

You're looking for a disc drive, but as you do so bugs swarm around and do unfriendly things to you. In an attempt to de-bug (ha, ha, ha) the system, you can shoot the various aliens. Like Durell says, it's well crucial man.

Screen movement is

reasonably pleasant but the real disappointment is the worm itself. It looks uncomfortably similar to a couple of triangles, stuck together by a black line. The Spindles rotate better.

The gameplay is pacey – things keep strolling along in their own time and Wormie can almost be described as achieving a decent lick in some places.

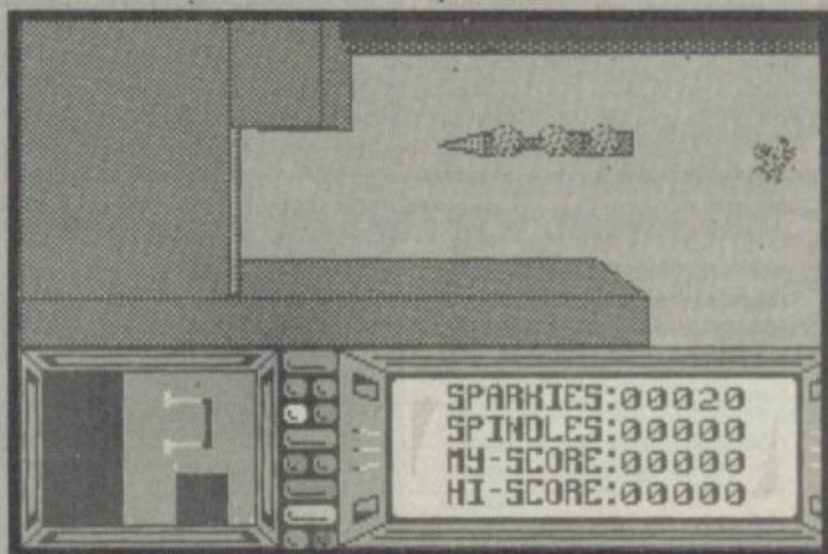

# SHEKHANA COMPUTER SERVICES

ORDER BY CREDIT CARD HOTLINE 01-809 4843 (24 HRS)

OUR PRICE	OUR PRICE	OUR PRICE	OUR PRICE
Gauntles.....6.95	Exploding Fist II.....6.95	Dandy.....5.95	Aliens.....7.50
Paper Boy.....5.95	Lightforce.....5.95	Cobra.....5.95	Cyruus II Chess.....9.95
Sky Runner.....7.95	Astrixs.....6.75	Academy.....7.50	Mailstorm.....5.95
Dan Dare.....7.50	Napoleon at War.....7.50	Marble Madness Kit.....6.95	Avenger-Tiger II.....7.50
City Slicker.....6.96	Tempest.....7.50	Dracula.....7.50	Konamis Coin Hits.....7.95
Scared Antirad.....6.95	Gallipoli.....7.50	Artist II.....12.95	Dodgy Geezers.....6.75
Theatre Europe.....7.95	Shao Lins Road.....5.95	Swords of Bain.....7.95	Vulcan.....7.95
Quazatron.....6.75	Cop Out.....6.95	Tobruk.....7.50	Master of Universe.....6.95
Strike Force Cobra.....7.50	Infiltrator.....7.50	Temple of Terror.....6.75	Breakthru.....6.95
Fat Worm Blows.....7.50	Galvan.....5.95	Super Cycle.....6.95	Cystal Castle.....7.50
Ace.....7.95	Commando 86.....5.95	Labarynth.....7.50	Xevious.....6.95
1942.....5.95	PS15-Trading.....6.75	Mag Max.....5.95	Super Soccer.....5.95
Pub Games.....7.50	Strike F.Harrier.....7.95	Yie Ar Kung Fu II.....5.95	Double Take.....5.95
Uridium.....6.75	Ghost and Goblins.....5.95	Bomb Jack II.....5.95	Glider Rider.....6.95
Konamis Golf.....5.95	Druid.....5.95	Ikari Warrior.....6.95	Now Games 3.....7.95
Zeno.....6.95	Durell Big 4.....6.95	Frost Byte.....6.75	Jail Break.....5.95
Elite.....12.95	Hardball.....6.95	Parallax.....5.95	Future Knight.....5.95
Firelord.....6.95	Annals of Rome.....10.95	Top Gun.....5.95	Traiblazer.....5.95
Scoboy Doo.....5.95	Stole a Million.....7.50	Sword of Samurai.....6.95	Colour of Magick.....7.50
Cyborg.....6.95	Desert Rats.....7.50	Now Games 3.....7.95	Space Harrier.....5.95
Its A.K.O.....5.95	Winter Games.....5.95	Jail Break.....5.95	Acrojet.....7.95
Tomahawk.....7.50	Leader Board.....6.95	Super Soccer.....5.95	Express Raider.....6.95
World Games.....6.95	Head Coach.....6.95	Yie Ar Kung Fu II.....5.95	Saracen.....6.95
Judge Dredd.....7.50	Battlefield Germany.....10.95	Double Take.....5.95	Saigon.....6.95
The Great Escape.....5.95	Terra Cresta.....5.95	Glider Rider.....6.95	5 Star Hits.....7.95
Thantos.....7.50	Monopoly.....7.95	Bomb Jack II.....5.95	Return to Oz.....6.50
Scalextric.....7.95	Silent Service.....7.95	Ikari Warrior.....6.95	Ice Temple.....6.50
Barooka Bill.....6.95	Footballer of Year.....5.95	Top Gun.....5.95	Tenth Frame.....6.95
Fairlight II.....7.50	Graphic Creator.....19.95	Sword of Samurai.....6.95	Saigon.....6.95
TT Racer.....7.50	Shockway Raider.....5.95	Now Games 3.....7.95	Shadow Skimmer.....5.95
The Goonies.....6.95	Star Raider II.....7.95	Jail Break.....5.95	Winter Wonderland.....5.95
Battle of Britain.....7.95	Explorer.....5.99	Future Knight.....5.95	Dark Sceptre.....7.50
Camelot Warrior.....6.95	Sold a Million 3.....7.50	Traiblazer.....5.95	Nexus.....7.95
Rogue Trooper.....7.50	Kayleth.....6.75	Colour of Magick.....7.50	Jewels of Darkness.....12.95
Deactivators.....6.95	PSI Chess.....7.50	Space Harrier.....5.95	
Tarzan.....6.75	Centurians.....6.95	Acrojet.....7.95	
Animator 1.....7.95	Deep Strike.....7.50	Express Raider.....6.95	
Swords of Bain.....6.95	Starglider.....12.95	Saracen.....6.95	
Uchi-Mata.....6.95	Tempest.....7.50	Saigon.....6.95	
	Trivial Pursuit.....12.95	5 Star Hits.....7.95	
	T.P Young Players.....12.95	Return to Oz.....6.50	
	T.P Question Pack.....7.95	Ice Temple.....6.50	
	**SPECTRUM 128K**	Tenth Frame.....6.95	
	Cyruus II Chess.....9.95	Saigon.....6.95	
	Ghostbusters.....7.95	Shadow Skimmer.....5.95	
	Fairlight.....7.95	Winter Wonderland.....5.95	
	Inter Match Day.....7.95	Dark Sceptre.....7.50	
	Call Me Trooper.....7.95	Nexus.....7.95	
	Winter Games.....7.95	Jewels of Darkness.....12.95	
	Master of Universe.....7.95		
	Austerlitz.....7.95		
	Tau Ceti.....7.95		
	Artist II.....14.95		

All prices include P&P in UK. Europe add £1 per tape. Elsewhere at cost.  
Cheque/PO payable to: S.C.S (Sinc) PO Box 394, London N15 6JL.  
Telephone 01-800 3156

If you would like to pick up your discount software from our shop, please produce your copy of this advert for above discounts. To SCS, 221, Tottenham Court Road, London W1R 9AF.

(Near Goudge St Station - Open 6 days a week 10.00am to 18.00pm.  
Barclaycard and Access hotline ☎ 01-809 4843 ☎ 01-631 4627.  
Credit Card orders dispatched same day - subject to availability.

\* New Releases subject to availability from Software House. Please ring for availability.

# POOLSWINNER

THE ULTIMATE POOLS PREDICTION PROGRAM

- **MASSIVE DATABASE** Poolswinner is a sophisticated Pools prediction aid. It comes complete with the largest database available - 22000 matches over 10 years. The database updates automatically as results come in.
- **PREDICTS** Not just SCOREDRAWS, but ALWAYS, HOMES and NO SCORES.
- **SUCCESSFUL** SELEC guarantee that Poolswinner performs significantly better than chance.
- **ADAPTABLE** Probabilities are given on every fixture - choose as many selections as you need for your bet. The precise prediction formula can be set by the user - you can develop and test your own unique method.
- **SIMPLE DATA ENTRY** All team names are in the program. Simply type in the reference numbers from the screen. Or use FIXGEN to produce fixture list automatically (see below).
- **DISC/MICRODRIVE COMPATIBLE** Tapes supplied with conversion instructions.
- **PRINTER SUPPORT** Full hard copy printout of data if you have a printer.



Boxed, with detailed instruction booklet

PRICE £15.00 (all inclusive)



FIXGEN 86/7

AT LAST! No more struggling for hours to get the fixture list into the computer. FIXGEN has been programmed with all English and Scottish fixtures for 1986/7. Simply type in the date, and the full fixture list is generated in seconds. Fully compatible with Poolswinner. Yearly updates available.

POOLSWINNER with FIXGEN £16.50 (for both)

## COURSEWINNER V3

THE PUNTERS COMPUTER PROGRAM

NOT JUST A TIPSTER PROGRAM, Coursewinner V3 can be used by experts and occasional punters alike.

You can develop and test your own unique winning system by adjusting the analysis formula, or use the program in simple mode. Coursewinner V3 uses statistical analysis of major factors including past form, speed ratings, course statistics, prize money, weight, going, trainer and jockey form etc. It outputs most likely winners, good long odds bets, forecasts, tricast etc. The database includes vital course statistics for all British courses. You can update the database - never goes out of date.

PRICE £15.00 (all inclusive) includes Flat AND National Hunt versions.

ALL PROGRAMS AVAILABLE FOR: AMSTRAD CPCs, AMSTRAD PCWs (ADD £3.00), All BBCs, All SPECTRUMs, COMMODORE 64/128, ATARI (486+), SINCLAIR QL.  
Supplied on tape (simple conversion to disc) - except PCW (on 3" disc) and QL (on microdrive)

Send Cheques/POs for return of post service to ...



phone 24 hrs



phone 24 hrs

37 COUNCILLOR LANE, CHEADLE, CHESHIRE. ☎ 061-428 7425

(Send for full list of our software)

# HIRE SPECTRUM SOFTWARE

- \* OVER 500 different titles available for hire including ARCADE, ADVENTURE, BUSINESS, EDUCATIONAL, etc.
- \* OVER 10,000 tapes in stock. All publisher's originals.
- \* **LOWEST HIRE CHARGES** - hire up to 3 tapes at a time, from only 63p (plus P&P and VAT) for 2 weeks hire.
- \* **FREE** printed CATALOGUE.
- \* **FREE** newsletter with hints, tips, reviews, etc.
- \* **TAPES** for sale at **DISCOUNT** prices, (eg **MANIC MINER** £2.00).
- \* **FAST, FAST SERVICE.** All tapes sent by 1st class postage.
- \* **HALF-PRICE OFFER** - **LIFE** membership **ONLY £3.00** (normally £6.00).
- \* **FREE** first hire tape. (For limited period).
- \* **EUROPEAN MEMBERS WELCOME** (Payment in Sterling).

Have you ever been disappointed with software you've purchased? Now you can hire it first. If you like it, buy it at £1.00 off our already discounted prices. If you don't, send it back and it will only cost you the hire fee.

**NSL** is the best **SPECTRUM** library, with over 8,000 delighted members, the largest range of tapes and controlled by our computer with 22 mb hard disc. **JOIN TODAY**, or, if you don't believe our claims write or 'phone 01-661 9240 for a catalogue, and check our competitors. We're confident you'll join **NSL**.

## NATIONAL SOFTWARE LIBRARY

42 Harefield Avenue, Cheam, Surrey SM2 7NE.

I enclose £3.00 for **LIFE MEMBERSHIP**. Please rush my membership kit to me. If, within 28 days, I'm not delighted with your service you'll refund my membership fee.

Name \_\_\_\_\_

Address \_\_\_\_\_

SU1

# CYRUUS II

## CHESS

£11.95

## THE GRAND MASTER

Available on: Spectrum 48K and 128K MSX Tape  
CBM64/128 Tape and Disk

**SPECIAL OFFER**  
Part exchange your old chess program for **ONLY £6.95**

Send cheques/postal orders for £6.95 and your old program to:

Alligata Software Ltd., 1 Orange Street,  
Sheffield S1 4DW Tel Order tel: (0742) 755796

ALLIGATA BITES BACK

# BACKGROUND NOISE

**B**ackground Noise looks behind the top games of the moment and speaks to the programmers who sweated blood to produce them. Background Noise looks from the author's point of view — at the particular programming problems and the way they were solved

## STARGLIDER

Team leader Paul Hibbard

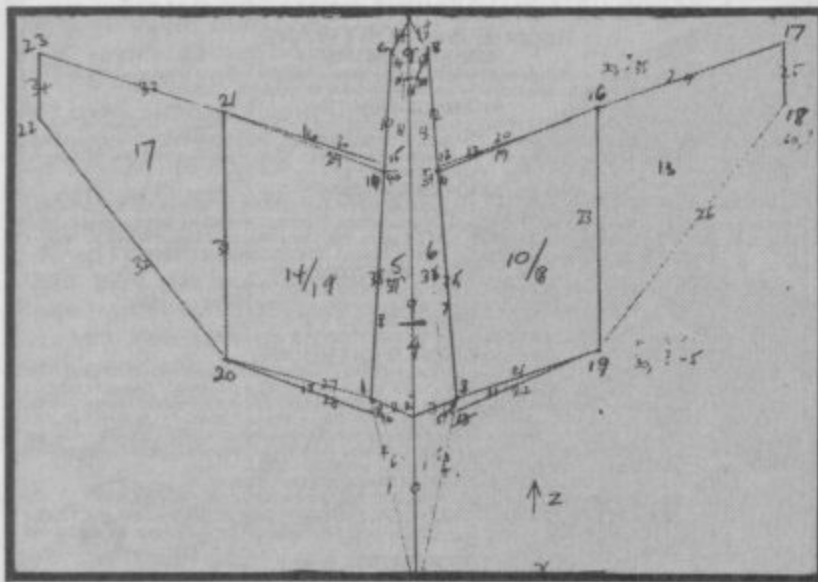

▲ One of the most complex designs at the original design stage.

**A**s Development Manager it was my task to ensure that the Spectrum version of *StarGlider* retained the feel of the Atari ST original.

*StarGlider* was designed to use the power and memory of the Atari ST. To convert the program to the Spectrum presented many problems which I had feared might be insurmountable but which, in the event, were solved.

In itself the move from the power of a 16 bit computer to an 8 bit may seem to have only tremendous disadvantages. The Spectrum does, however, have some advantages over an Atari ST. The screen of the Atari is 32K, in comparison to 8K of the Spectrum, and this means that less work in the program is required to address screen memory.

As in most recent programs *StarGlider* uses a dummy screen area on which all the work is done before being transferred to the real screen. On the ST this can be done by telling the hardware to point to a new area of memory for the screen. The Spectrum does not have the luxury of 'screen flipping' and must rely on a piece of machine code to dump the dummy area to screen memory.

Another constraint in the Spectrum was the memory size. The ST version was only restricted by

disc space, which was about 400K compared to the Spectrums meagre 48K. The memory problem was overcome by taking out some aspects that the Spectrum could not cover such as digitised music (80K), digitised speech (32K), and a reappearance of the loading screen (32K). As I have already mentioned the difference in the size of the screen memory is an important feature and this means that it was possible to save at least 24K in the Spectrum when storing the control panel and missile screen. Other memory was saved by careful changes in the data structure of the maps of the *StarGlider* world which was reduced in a manner that would

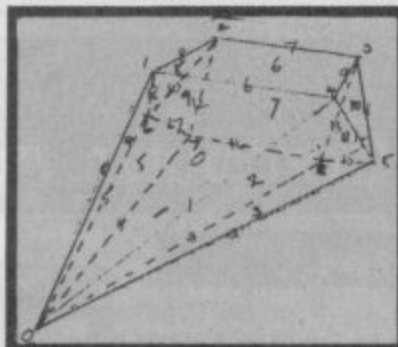

▲ Sometimes seemingly simple shapes proved complex to define

▼ The Silo launcher which rotates and seems to 'launch' missiles

not be obvious to anyone except a mapping freak.

It was necessary to remove certain elements from the Spectrum 48K, version although I was pleased that some of these were retained in the 128K version. The 128K does include the same digitised speech as the ST but using a slightly different sample rate. The speech was in fact originally sampled on an Amiga and this was used in both the versions. It took a long time to record the speech to get clear samples and everyone in the office had a go to see whose voice sounded best. In the end Clare Edgeley had to suffer the embarrassment of repeatedly saying earth shaking phrases such as 'docking complete' and 'missile launched'. Clare had to repeat these phrases so many times that she became brainwashed and now still says them in the middle of ordinary conversation.

It was not possible to use the original digitised music but Dave Lowe, programmed three part music for the 128K.

One of the most significant features of *StarGlider* is the animated vector graphics. To get the animation it was necessary to design the basic object with its coordinates for each point and then work out new coordinates for any moving points for each frame of animation. A new drawing for each frame was required so that each point could, be calculated in relation to the centre of the object. The *StarGlider* itself had 23 points

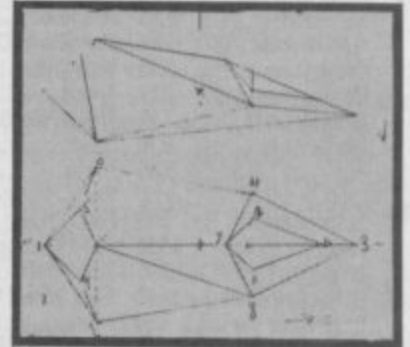

▲ Geometric shapes at the heart of tighter design

and required 22 frames of animation which gives an indication of the amount of work that was required.

When designing the objects it was very important to give consideration to the number of points used as they all require calculation by the program each time the object is redrawn on every new frame of the screen. It is, however, surprising that some of the more complicated looking objects can have fewer points simply by using a sneaky design.

Another significant consideration vital to 3D games is how something appears to the eye rather than what may be considered to be mathematically correct. Various tricks are used in *StarGlider* to give the impression of depth. Possibly the most obvious (well it will be now) is the control panel. There had been so many games with spaceship panels looking flat I decided to use a false perspective to give a feeling of depth. After filling my waste bin with various designs I finished up with the one now used in all versions. I was especially pleased with the way it gives the impression that the scanner slopes into the screen.

A constant feature of the programming was devising tricks to minimise use of memory space. Swapping bits of graphics not required on screen into a buffer, with careful planning, can condense the memory requirements. At other times the same buffer can be used to expand compressed data.

Another technique was to use self modifying code. This is useful if you have a long piece of code that with small changes would serve as another routine. A short piece of code is written to poke the routine to change how it operates. I hasten to add that this method of programming is not for the novice or nervous and is totally against standard teachings. We did it anyway.

Paul Hibbard

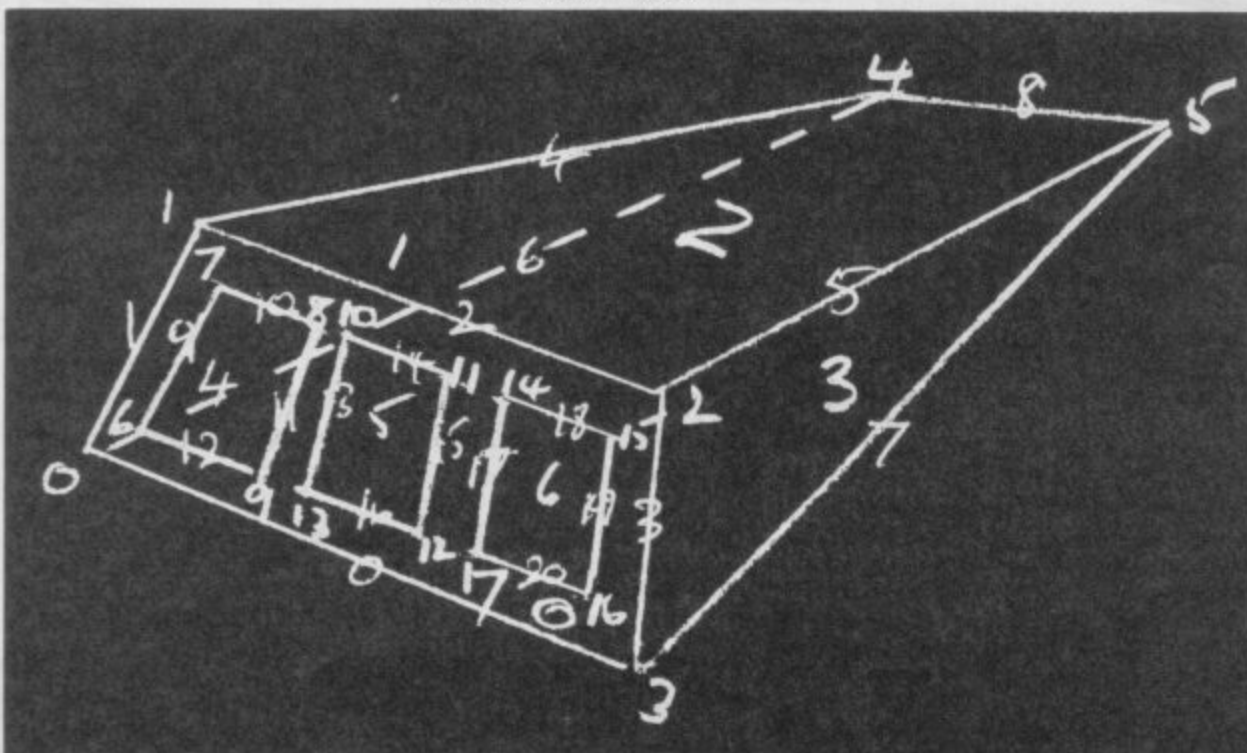

## MEGASAVE FANTASTIC SAVINGS

Yie Ar Kung Fu II.....	5.95	Jail Break.....	5.95	Great Escape.....	5.95
Rambo II (Cobra).....	5.95	Jack the Nipper.....	5.95	Astrix.....	6.75
Thai Boxing.....	5.95	SAS Strike Force.....	6.75	Fire Lord.....	6.75
Ace.....	8.00	Tarzan.....	5.95	Hilander.....	5.95
Grph Adv Creator.....	19.50	Dan Dare.....	7.50	Double Take.....	5.95
Inheritance.....	7.50	PSI Chess.....	7.50	Mag Max.....	5.95
Stole a Million.....	7.50	Super Cycle.....	5.95	Konami's Golf.....	5.95
Crystal Castles.....	7.50	Uchi Mata.....	6.75	Super Soccer.....	5.95
Fairlight II.....	7.50	Galvan.....	5.95	Terra Cresta.....	5.95
Top Gun.....	5.95	TT Racer.....	7.50	Konami's Arcade Hits.....	5.95
Dynamite Dan II.....	5.95	Rogue Trooper.....	6.75	Shock Way Rider.....	5.95
Elite.....	11.25	Revolution.....	7.50	1942.....	5.95
Pub Games.....	7.50	Explorers.....	5.95	Street Hawk.....	5.95
Ace of Aces.....	6.75	Glider Rider.....	6.75	Hit Pack Elite.....	7.50
Trail Blazer.....	5.95	Headcoach.....	6.75	After Shock.....	7.50
IKARI Warriors.....	5.95	Strike Force Cobra.....	7.50	Bazoooka Bill.....	6.75
Xevious.....	5.95	Vera Cruz.....	6.75	Legions of Death.....	7.50
Silent service.....	7.50	Animator 1.....	7.50	Gauntlet.....	7.50
Sold A Million III.....	7.50	Trivial Pursuit.....	12.50	Future Knight.....	5.95
World Games.....	6.75	Droid.....	5.95	Scooby Doo.....	5.95
Paper Boy.....	5.95	Aliens.....	7.50	Exon.....	6.75
Graham Gooch.....	7.50	Shao-lin's Road.....	6.75	Orbix Terriball.....	5.95
Spitting Images.....	5.95	Leaderboard.....	5.95	Cak Trap.....	6.75
Cholo.....	12.50	PSI-5 Trading.....	5.95	Masters of the Universe.....	6.75
Breakthru.....	6.75	Tau Ceti II.....	7.50	Academy.....	6.75
Botham's Cricket.....	5.95	Footballer of Year.....	5.95	The Press.....	6.00
Strike Force Harrier.....	7.50	Avenger.....	7.50	Judge Dredd.....	6.75
Theatre Europe.....	7.50	Now Games III.....	7.50	Sky runner.....	7.50
Dandy.....	7.50	Durell Big Four.....	7.50	P.A.W.....	19.50
Johnny Reb II.....	7.50	Nightmare Rally.....	5.95	Delcon.....	6.75
Spitfire 40.....	7.50	The Archers.....	7.50	East Enders.....	7.50
Temple of Terror.....	7.50	Uridium.....	6.75	Handball Maradona.....	5.95
Trap door.....	6.75	Star Raid II.....	7.50	Marble mad. Con. Set.....	6.75
Colour of magic.....	7.50	Hard Ball.....	6.75	Big Trouble in L.China.....	5.95
Space Harrier.....	5.95	Cyborg.....	6.75	Cop Out.....	6.75
Fist II.....	6.75	Dodgy Geezers.....	5.95	Deep Strike.....	7.50
Art Studio.....	12.50	Light Force.....	5.95	Twice Shy.....	7.50
Ghosts & Goblins.....	5.95	City Sliker.....	6.75	Napolean at War.....	7.50

Postage Included UK. Please state which micro. Fast Service  
Send cheque/PO to: MEGASAVE, Dept. SU1  
49H Sutherland Street, Victoria, London SW1  
Mail Order only

## FOOTBALL MANAGEMENT STRATEGY GAMES

from E & J SOFTWARE

48K SPECTRUMS

3 quality football games for serious enthusiasts. Each game uses the full available memory of your Spectrum or Spectrum+ and is packed with genuine features.

### PREMIER LEAGUE

OUR COMPREHENSIVE AND EXCITING LEAGUE GAME - FEATURES INCLUDE: Training, Team Selection, Substitutes, Half-Time Scores, Full Squad Details, Named Goal Scorers, Team Styles, Save Game, Financial Problems, 5 Skill Levels, Transfer Market, Injuries, Continuing Seasons, Printer Option, PLUS MANY MORE!

### EUROPEAN TROPHY

A SUPERB EUROPEAN COMPETITION STYLE GAME WITH THESE FEATURES: Home & Away Legs, Away Goals Count Double, 2 Substitutes Allowed, Extra Time, Penalty Shoot-Outs (with sudden death), Match Injuries, Injury Time, Match Penalties, 5 Skill Levels, Pre-Match Reports, Team Selection, Named Goal Scorers, Save Game, Printer Options, PLUS MANY MORE!

### SPECIAL FEATURE

Transfer your PREMIER LEAGUE winning side into EUROPEAN TROPHY  
Both these games can be played separately or as COMPANION GAMES.

\*\*\* Games £5.25 each \*\*\*

SPECIAL TWIN PRESENTATION PACK OF BOTH GAMES AVAILABLE AT ONLY £9.95

### and now! WORLD CHAMPIONS

An exciting World Cup Football Management simulation taking you from the first warm-up friendlies through the qualifying stages, Four Matches and onto the finals. LOOK AT THESE FEATURES! Select Team from Squad of 25, Pre-Match Team News, Disciplinary Table, Full Results List, Match Suspensions, Change Player or Team Name, League Tables, 7 Skill Levels, Save Game, Printer Option, PLUS MANY MORE! WORLD CHAMPIONS features a superb comprehensive text match simulation including the following: Match Timer, Named Goal Scorers, Goal Times, Corners, Free Kicks, Injuries, Bookings, Penalties, Sending Off, Injury Time, Penalty Shoot-Out.



\*\*\* ALL THIS AT THE UNBEATABLE VALUE OF £6.95 \*\*\*

All games now in stock for immediate despatch - order your copies now!

FANTASTIC VALUE - ORDER ALL THREE GAMES FOR ONLY £15.95

All prices include postage and packing (add £1.00 outside UK) Available by mail order only.

E & J SOFTWARE, Room 1,  
37 Westmoor Road, Enfield, Middx, EN3 7LE



## MATHEMATICS

TRANSFORMATIONS  
SETS  
STATISTICS

Spectrum	BBC
✓	✓
✓	✓
Dec 86	Jan 87

These modules are a powerful learning and revision aid for GCSE & GCE O' Level students. Each module comprises a SOFTWARE TOOLKIT which solves any mathematical problem and a comprehensive MANUAL (spiral bound, 40-50 pages) containing a wide range of examples and problems to work through with the computer.

£8.95 for 48K Spectrum (cassette) £9.95 for 32K BBC (disk)

P & P 60p per module. Cheques to 'Alphaplus Educational Software'.

For free information  
write to

ALPHAPLUS EDUCATIONAL SOFTWARE  
1 Leigh Road, Highfield,  
SOUTHAMPTON, SO2 1EF.

# TRANSFORM LTD.

## Computer Accessories



- Fully Interlocking
- Hold 20 cartridges

### MICRODRIVE STORAGE BOX

Box + 10 cartridges ..... £22.45p  
Box + 20 cartridges ..... £39.95p

- Microdrive storage box is available from W.H. Smith, John Menzies and Spectrum.

### MICRODRIVE CARTRIDGES

10 Microdrive cartridges ..... £17.50p

### DUST COVERS

QL Dust Covers ..... £5.00p  
Spectrum + ..... £4.00p  
Amstrad Keyboard ..... £4.00p  
Amstrad Monitor ..... £4.00p

### DISKS

3 1/2" S/S S/D ..... £2.70p  
3 1/2" D/S D/D ..... £3.00p  
5 1/4" S/S S/D ..... £1.50p  
5 1/4" D/S D/D ..... £1.70p

### DURADATA PRINTOUT BINDERS

5511 6 1/4" - 9 7/8" x 12" ..... £2.82p  
5513 11 1/4" - 14 1/2" x 12" ..... £3.44p  
5514 13 1/4" - 15 15/16" x 12" ..... £3.80p

Available in black, blue, green, red & yellow.

### DISK STORAGE BOXES

3" Box (holds 20 disks) ..... £13.25p  
3" Box (holds 40 disks) ..... £17.00p  
3 1/2" Box (holds 40 disks) ..... £13.25p  
3 1/2" Box (holds 80 disks) ..... £17.00p  
5 1/4" Box (holds 40 disks) ..... £15.75p  
5 1/2" Box (holds 80 disks) ..... £19.00p



- LOCKABLE
- BROWN TINTED REMOVABLE LID
- DIVISIONS & INDEX TABS

### SPECTRUM RGB INTERFACE

RGD Interface (TV/MONITOR) ..... £45

- Please add £1.00 postage and packing.



TRANSFORM LTD. (Dept. SU1) 089 283 4783  
Mail order only. Lucks Lane, Paddock Wood, Kent TN12 6QL.



You might think that I review games because I get paid for it, but it's not true (well, almost). Really I do it for love – waiting for a game like Samurai to appear. Something like this just makes it all worth while.

Need some background? Right, here it is in a nutshell. You control a force of Japanese warriors. You have to attack a temple and kill all the warrior monks who are defending it.

# SAMURAI

And that's basically it – simple, clean and fast.

To begin with, you have to pick your forces. Depending on the difficulty level, you have from 200 to 400 points to spend. Mounted Samurai cost 40 points, Ninja (assassins) cost 25 points, a unit of Ashigaru (second rank foot soldiers) 18 points, and a Samurai 12 points. You are free to choose whatever mix you like, so long as you don't exceed the points you are allowed.

Your opponent, the computer, has a force of monks, trained in martial arts and wielding two-handed swords: Samurai monks, apparently regarded as the top warriors of Imperial Japan, and young Samurai monks still in training.

You choose your forces by selecting from a range of icons. Move the joystick until the icon you want flashes, hit fire and a unit with that icon on appears in the playing area window which takes up about a third of the screen.

When you're satisfied with the make-up of your forces, then you can start the game. As far as I can work out, there is only one map – but what a map! It's one of the best pieces of static graphics I have ever seen on the Spectrum – in fact,



to be honest, on just about any computer including the Atari ST and Amiga.

You see, in the map window, an aerial view of a Japanese temple and the land immediately surrounding it. Everything is perfect – grass, paving stones, chairs, statues, water, wooden planking: someone has taken an immense amount of effort on this.

Dotted about the map are the various warriors under your command, and centred on the temple – which is in the middle of the map – are the enemy forces. Warriors appear as square counters with the icon showing what they are on them. Yours are orange, the enemy's are blue.

The computer automatically cycles through your units. When it centres on one, you have to move the joystick until the icon you want is flashing, then hit fire. So if you choose the icon that looks like a pair of feet, that represents movement: you then move the flashing on-screen cursor to where you want your man to go. To the right of the map window is a status screen, which indicates how many movement points he has left, and how strong he is. Strength starts at about 30, and when a soldier reaches one he is dead and removed from the map.

To attack, you move a unit

▲ Foot fighters and mounted troops do battle

next to an enemy force. Then, when you've moved everybody you want to, combat takes place. Everybody adjacent to an enemy attacks and is attacked by that enemy.

The only exception to this rule is the Ninja, who can engage in ranged combat. Choose the icon representing a Bhuriken, or throwing star, and

▼ Outside the city walls, with much fighting on the battlements

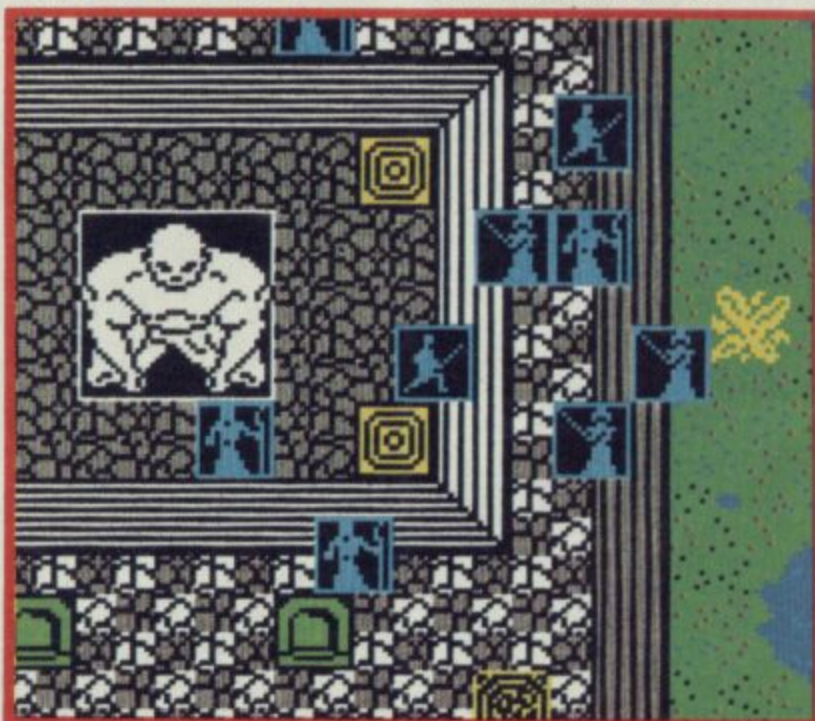

## STRATEGY SIMULATION



## REVIEW

press fire; to the right of the map window you see a circle with a white line. Use the joystick or cursor controls to move the line until it's pointing in the direction you want to throw your star, then hit fire again. If you are close enough, then you have a good chance of hitting. Once a Ninja has thrown his star for that turn, he still has some movement points left – so you can throw and engage the target you have already damaged, or throw and run away.

While historically this is somewhat inaccurate, as Samurai were excellent bowmen, in game terms it works very well. You can also call up a second, smaller, map which allows you to scout out the temple. I didn't realise this, and spent the entire game (actually all four I managed to play) in the dark. I got slaughtered – but I probably would have done anyway, as Samurai isn't the easiest of games.

Samurai is not one of the most complex of games, but that works in its favour. It plays fast and it's addictive. Every time you get wiped off the map you keep coming back for more. And the graphics are so good that it's a joy to play. I haven't seen a game this good in a long time.

The only thing that worries me is that it could be a bit limited: but the design-your-own-side mechanics should allow for varied games ■

### FACTS BOX

*Samurai is absolutely brilliant, superb, and wonderful. I can't wait to see a follow up. A classic strategy game*

★	SAMURAI
★	Label: CRL
★	Author: In-house
★	Price: £9.95
★	Memory: 48K/128K
★	Joystick: Various
★	Reviewer: <i>Games Look</i>

# INSTANT CURE ADD



Another classic Atari coin-op hits the 64! ZZAP 64

**XEVIOUS**  
XEVIOUS

## XEVIOUS

Many eons ago, an advanced technologically orientated civilization was forced to evaluate the Earth prior to the Ice Age. Now, these Xevious people are returning to reclaim their heritage through conquest. From the controls of your Solvalu super spacecraft, you must defend the Earth from takeover by the Xevious invaders!

CBM 64/128 <sup>Ⓣ</sup> <sup>Ⓛ</sup>  
AMSTRAD £9.99 £14.99

SPECTRUM 48K £7.99 <sup>Ⓣ</sup>

100x 10p

No more pushing, no more shoving. Long agitated queues in noise filled emporium of glitter and shine. And then when you get to your ultimate challenge, the test you've eagerly longed for..... it's over..... money gone, gobbled up by insatiable drones in a matter of seconds. Will you ever attain superhero status? Don't wonder any longer, U.S. Gold bring you four outstanding classics with all the excitement and realism of their arcade originals in the comfort and warmth of your own home.

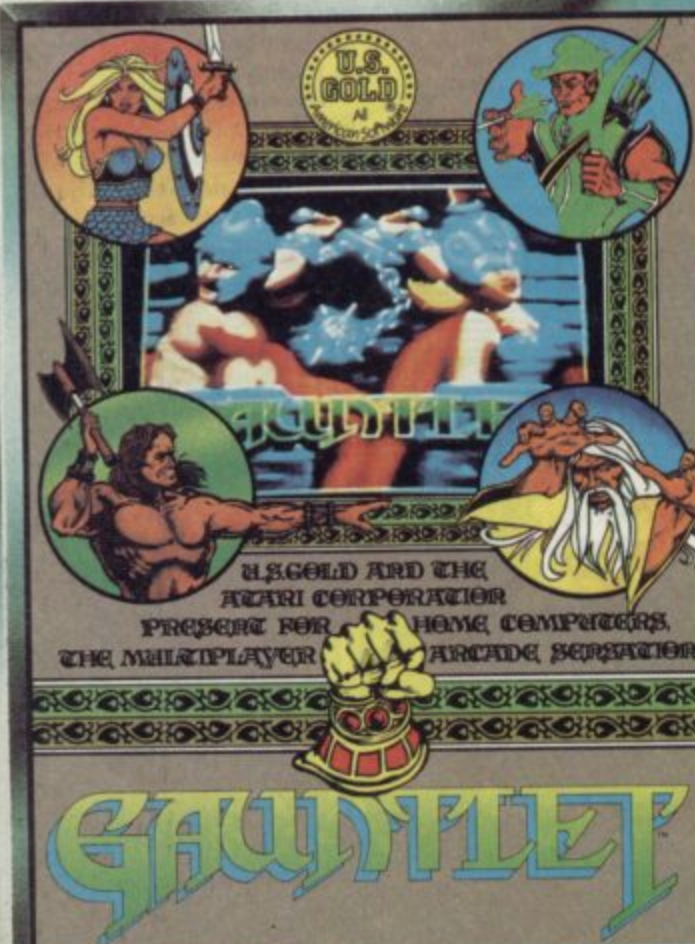

U.S. GOLD AND THE ATARI CORPORATION  
PRESENT FOR HOME COMPUTERS  
THE MULTIPLAYER ARCADE SENSATION

**GAUNTLET**

## GAUNTLET

Enter the world of monsters and mazes. Travel the path of mystery and combat in search of the food that replenishes your 'health'. Your way is barred by an array of monsters and legions of enemy beings but they are not your only foe in the quest for food, treasure and magic potions - your fellow players compete in search of the same good bounty.

CBM 64/128 <sup>Ⓣ</sup> <sup>Ⓛ</sup>  
AMSTRAD £9.99 £14.99  
ATARI (no disk)  
MSX

SPECTRUM 48K £8.99 <sup>Ⓣ</sup>

AMIGA/  
ATARI ST <sup>Ⓛ</sup>  
IBM £24.99

100x 10p



U.S. Gold Ltd.,  
Units 2/3, Holford Way,  
Holford, Birmingham B6 7AX.  
Tel: 021 356 3388



# E FOR ARCADE ICTS



## BREAKTHRU

Your mission - retrieve PK430 your country's revolutionary fighter... location - 400 miles behind enemy lines... possible enemy armaments - flame throwers, helicopters, tanks, jeeps, landmines... your equipment - the world's most sophisticated armed vehicle... mission status - vital... mission consequences - world peace... mission objectives - you must...

CBM 64/128 <sup>Ⓣ</sup> <sup>Ⓜ</sup>  
AMSTRAD £9.99 £14.99

SPECTRUM 48K £8.99 <sup>Ⓣ</sup>



100x **10p**



## CRYSTAL CASTLES

Crystal Castles is a once in a lifetime opportunity to experience a true software legend. A legend that will continue because it is to be produced as a Limited Edition. Now that you've heard of it you must buy it otherwise you'll have missed a true software experience.

CBM 64/128 <sup>Ⓣ</sup> <sup>Ⓜ</sup>  
AMSTRAD £9.99 £14.99  
BBC

SPECTRUM 48K £8.99 <sup>Ⓣ</sup>  
ELECTRON



100x **10p**

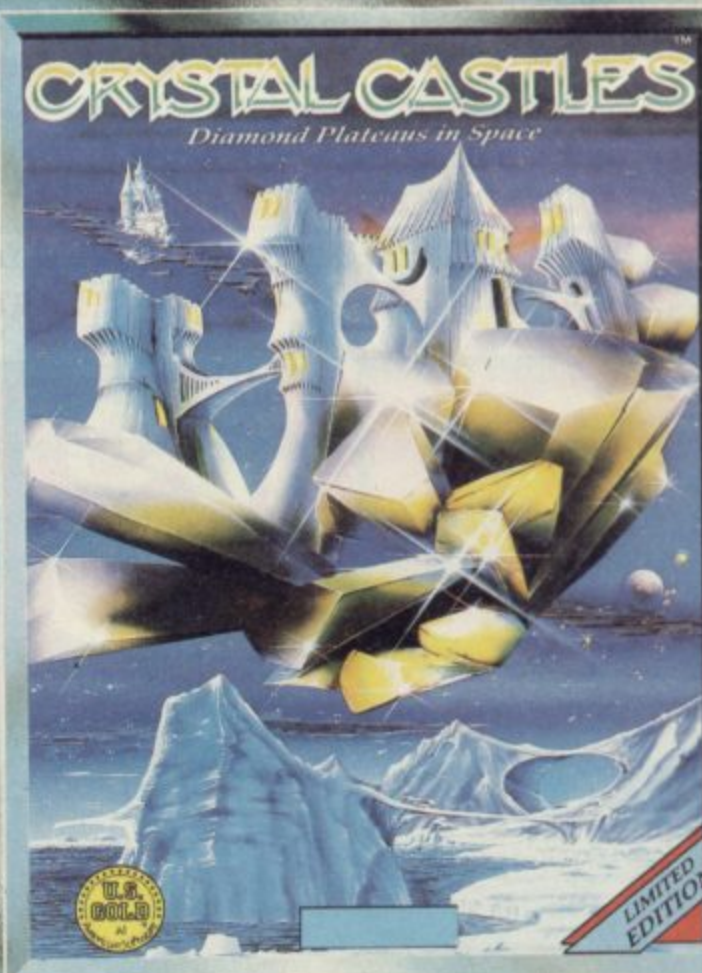

SU's amazing competition: The only one IN THE WORLD where YOU are guaranteed to win a prize!!

I T S



250 copies of ACADEMY, from CRL ● ARGUS PRESS are giving us 20 GLIDER RIDER tapes ● US GOLD 40 assorted POSTERS from ARIOLASOFT ● CASCADE have 30 copies of LIFE OF HARRY ● JOYTOIC DIGITAL INTEGRATION have got 30 copies of FIGHTER PILOT ● PALACE SOFTWARE are giving away OF ANTIRIAD ● TASMAN have 10 copies of the 64 column-print utility, TASWIDE ● GARGOYLE has got PIRANHA! We've got 12 copies of each of its games; POPEYE, TRAPDOOR, STRIKE FORCE COBRA, TROOPER ● PYRACURSE tapes number 20, and they're from HEWSON, along with 20 posters of the SHIRTS AND BADGES ● FIREBIRD offers you 50 assorted games! ● Up from down under are FIST IN MELBOURNE HOUSE ● OCEAN has come up with 100 copies of its amazing ROLAND RAT! ● There are Whoosh! 200 copies of ROCKY HORROR have just arrived from CRL! ● XENO is great, and there is a BADGES from ARIOLASOFT ● We've got 30 SKY RUNNER POSTERS from the splendid CASCADE crew and it comes from DIGITAL INTEGRATION ● There are 20 MASTERTRONIC T SHIRTS up for grabs, too, just waiting to be snapped up! ● GARGOYLE gave us 50 copies of AD ASTRA to hand out ● EEEK! Help! ● There are 20 copies of the wonderful QUAZATRON POSTER from HEWSON ● 25 STRIKE FORCE ZYTHUMs come from MIRRORSOFT ● Want to dress like DREDD? There are 5 JD T SHIRTS from magically appeared from RAINBIRD SOFTWARE ● CRL have given us a whacking 200 copies of their wargamers. We've got about 20, from ARGUS PRESS ● Then there are 5 assorted T SHIRTS from ARIOLASOFT ● 30 ACE POSTERS! ● There are 50 of MASTERTRONIC's best games awaiting collection, too! ● GARGOYLE has 50 copies of TIR NA NOG ● A fantastic 24 PIRANHA T SHIRTS will keep you warm in the coming months from the HEWSON people ● Become BIGGLES, with 25 copies of his game from MIRRORSOFT ● MELBOURNE has 50 copies of BAZOOKA BILL SUNGLASSES ● And we have 3 copies of the stunning STARGLIDER in the form of 20 MARSPORTS, and 15 copies of HEAVY ON THE MAGIK ● There are 200 copies of JUGGERNAUT signed by the ENTIRE ENGLAND TEAM from ARGUS ● VIRGIN GAMES have given us 300 STRANGELOOPS II ● 10 NOW GAMES ● 10 copies of STRANGELOOP ● And 10 DAN DAREs ● 1 sparkling brand new

I S N' S T





**S GOLD** have come up with 50 copies of **BREAKTHRU** ●  
**BOYSTICKS** arrive from **MASTERTRONIC**. We've got 5 ●  
 ing away copies of the Classic game, **SACRED ARMOUR**  
**E** has got 20 copies of **DUN DARACH** ● Lots of stuff from  
**OBRA**, **COLOUR OF MAGIC**, **NOSFERATU** and **ROGUE**  
 of the game ● **MIRRORSOFT** are giving 10 **BIGGLES T-**  
**FIST II POSTERS**, and 20 **JUDGE DREDD BADGES** from  
 There are 50 **STARGLIDER POSTERS** from **RAINBIRD** ●  
 re is a whole sackful from **ARGUS PRESS** ● There are 20  
**DE crew** ● **NIGHT GUNNER** will keep 30 winners happy,  
 rabs, too ● We've got 500 **ANTIRIAD** posters from **Palace**,  
 eek! 12 fluffy **PIRANHAS** have appeared from nowhere.  
**FORCE HARRIER** posters, 25 **DYNAMITE DANs** and 25  
**S** from **MELBOURNE HOUSE** here ● **PAWN POSTERS**  
 of their game **FORMULA 1** ● **JOHNNY REB II** will satisfy  
**ARIOLASOFT** ● **CASCADE** came up with an astounding  
**GARGOYLE** are giving away 10 **T SHIRTS** (5 med/5 small)  
 ming months ● There are 20 copies of **QUAZATRON** from  
**MELBOURNE HOUSE** have given us 20 copies of assorted  
**ARGLIDER** from **RAINBIRD** ● More from **Gargoyle** in the  
**JUGGERNAUT** from **CRL** too ● We've got a **FOOTBALL**  
**LANGLOOP POSTERS** ● 50 copies of **SPECIAL PATROL**  
 nd new 128K+2 machine from **Amstrad** ● And so on . . .

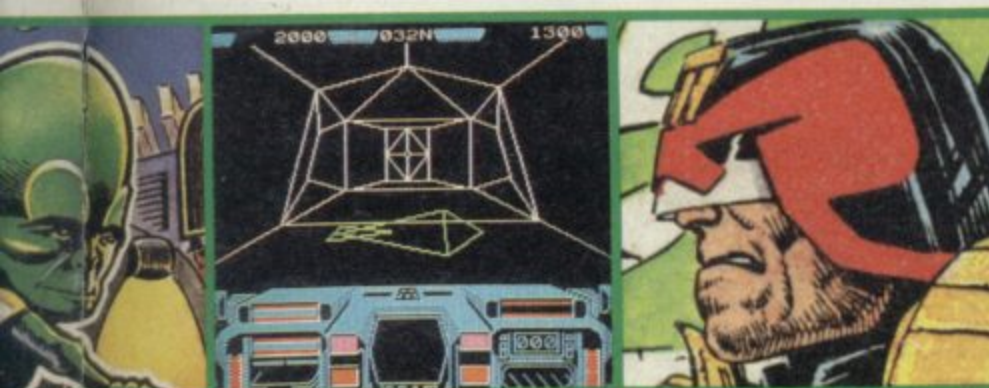

# EVERYONE'S A WINNER



The competition that you have all been waiting for. If we were to tell you that this competition was the most fantastically, stupendously **HUGE** competition in the history of computing, then you would have some idea of the proportions of this bumper Christmas event.

In a fit of unparalleled generosity, we at **SU** have decided to give **EVERY READER** who enters the compo **A PRIZE!**

Most software houses worth their salt are here, with their hottest products up for grabs. Don't forget, everyone's a winner. All you have to do is fill in the coupon below, answer our Reader's Poll over the next page and pull out this page and the Readers' Poll, send it to us at the address below and wait your prize.



**AND** even if we run out of prizes before we get to your entry, we're gonna print **Cassette Labels**, emblazoned with the **SU** logo, and you can have at least one pair of labels.

All you have to do is fill in the Readers Poll coupon overleaf together with the coupon below, and sent it along with a SAE to . . . Sinclair User "Fantastically and Absurdly Generous Competition", Priory Court, 30-32 Farringdon Lane, London EC1R 3AU.

Name: .....  
 Address: .....  
 .....  
 .....

Do you want a prize? Please tick appropriate box.  
 Yes.  Not really.

Note! Entries will be disqualified unless accompanied by a complete Reader's Poll!



**NOW TURN OVER FOR THE READER'S POLL COUPON**





**We** at **SU** know that our readers are just dying to talk about themselves. And why not? We already know that they have by far the best tastes in reading material. Simply by filling in the questions below, you will qualify for the fabulous **SU** Mega Competition, in which every entrant wins a prize. In this in-depth survey, we ask probing questions, so you can tell the software (and hardware) houses where they're going right - or wrong! Tell them what **YOU** think. If the questions get a little tough at times, stick at it. We know you can do it!

## The Questions

Best overall program of 1986

Peripheral of the year

Most exciting software house

Programmer of the year

Worst product of 1986

Best soundtrack of a game

Best graphics in a game

Best adventure game

Best toolkit program

Best Arcade game

Best/Worst Film/

a).....  
b).....

Best/Worst LP/

a).....  
b).....

Best strategy/wargame

What colour should the +2 have been?

Best piece of QL software

Rip-off of the year

Most horrific licencing deal

Best licencing deal

Most attractive programmer

Div of the year

Most unforgivable marketing concept of 1986

Computer character who you most enjoy watching die

Least impressive new software house

Best Dressed Industry Figure

Adventure with the smallest vocabulary

Dullest arcade game

Most ridiculous event of 1986

**NOW, TO ENTER THE MEGA COMP FOLLOW THE INSTRUCTIONS ON PAGE 67. AND DON'T FORGET TO ENCLOSE A STAMPED ADDRESS ENVELOPE.**





# HiSoft BASIC Compiler

Quite simply the fastest, most compact, most complete, most easy-to-use ZX BASIC compiler available for the Spectrum, Spectrum +, Spectrum 128 & Spectrum Plus 2

HiSoft BASIC for the Spectrum is a brand new floating point compiler packed full of professional features, yet so easy to use with simple one character commands. The compiler is only 11K long & compiles up to 30K of BASIC without tape or microdrive. This is the compiler that everybody else has been trying to produce.

'If you ever write anything in Basic or machine code this programme is a must - it works like magic. Buy it' *Sinclair User*

**£24.95**

## HiSoft Pascal & C

HiSoft Pascal is an almost complete implementation of Pascal; it runs super fast and comes with Turtle Graphics. The only Pascal on the Spectrum and the best **£25**

HiSoft C is an integer Kernighan & Ritchie compiler with graphics & sound support. New version 1.3 contains lots more features **£25**

## HiSoft Devpac

HiSoft Devpac is the original and definitive assembler/debugger for the Spectrum. Macros, conditional assembly, large assemblies, single step, breakpoints, small in size for maximum flexibility, simply the standard development pack **£14**

Other products include Ultrakit & Colt, a super fast integer compiler with sprites. Please write or phone for full details of all our products. Order by phone using Access or Visa or by post with a cheque / postal order.

## QL Products

DevpacQL is a fast, integrated assembler/editor and debugger package. New, low price **£29.95**

MonQL, debugger/disassembler out of DevpacQL is available on µdrive & ROM at **£14.95/£29.95**

SuperBEE contains more than 70 SuperBASIC extensions on ROM. Now reduced to only **£19.95**

**HiSoft** The Old School, Greenfield, Bedford, MK45 5DE (0525) 718181

**THE FIRST EVER SUPER SPARKLER**

## THE SAS: OPERATION THUNDERFLASH!

The first ever Super Sparkler! Only **£2.99** for a super 3-D graphic game. Your task as leader of the SAS squad is to spearhead an offensive against the terrorists who have occupied a foreign embassy. Can you stay the pace?

**SPECTRUM 48K**



**SPIKE'S No1 HIT**



## Spike Sparkler's pick of the Christmas hits at only £1.99 each

### BARGAIN BASEMENT

**SPECTRUM 48K**

Get in training for Christmas with this insane spending spree. Join Money on his race through the bargain basement as he goes shopping with his EXCESS CARD. The action takes place in Harrod's the world famous department store. **SPARKLE RATING \*\*\*\*\***

### SMUDGE AND THE MOONEES

**SPECTRUM 48K**

Smudge, the French chimney sweep with the dash of gallic charm embarks on a clean 'sweep' of the Paris roof-tops. Watch out for the Moonees however, who seek to thwart his progress. Highly playable! **SPARKLE RATING \*\*\*\*\***

### JAVA JIM

**C64 & ATARI**

Idaho Jim sets off on an epic archaeological expedition. He has to stop pretty smartly to avoid molten lava, swing across crumbling pits and dodge man-eating spiders. You're bound to dig this! **SPARKLE RATING \*\*\*\*\***

### SLURPY

**C64**

Deep in the caverns of the planet Gluton lives our famished friend Slurpy. Suffering from an acute bout of appetite fever he gobbles up everything in sight - but look out there's danger lurking in them thar caverns! **SPARKLE RATING \*\*\*\*\***

### SPECIAL DELIVERY

**ATARI**

Poor old Santa! He's overslept again and now has only 5 hours to deliver all his Christmas goodies. Help him sort out this chaos by collecting and dropping the gifts down the right chimneys. **ALSO ON SPECTRUM 48K SPARKLE RATING \*\*\*\*\***

### ORC ATTACK

**C64**

Defend the castle against the hordes. As Eric the Brave you have to fight off waves of murderous Orcs, outwit and slay the evil Sorcerer, and defeat the gigantic Demon Troll. Six play levels. **ALSO ON SPECTRUM 48K SPARKLE RATING \*\*\*\*\***

### RIVER RESCUE

**ATARI**

This race against time depends entirely on your skills as a navigator and pilot. But you are not without help. As the owner of the fastest power boat in the region you can rely on it to steer you to the rescue of the trapped scientists. But look out for crocs, rocks and mine-dropping rivals. **ALSO ON SPECTRUM 48K SPARKLE RATING \*\*\*\*\***

THE LATEST FROM SPARKLERS ALSO INCLUDES:

MONKEY MAGIC ON C64

TANK COMMANDER ON ATARI

COMPUTER WAR ON ATARI

AVAILABLE FROM ALL GOOD SOFTWARE STORES

Unit B11, Armstrong Mall, Summit Centre, Southwood, Farnborough, Hants. GU14 0NP. Tel: 0252 522200.

*Sparklers*



### Favourite ten things in the Universe

- 1 Single: Warriors of the Wasteland by Frankie Goes to Hollywood.
- 2 Album: Arena, by Duran Duran. It's live and I can forgive Simon Le Bon's David Bowie impression.
- 3 Video of Wild Boys by Duran Duran.
- 4 Film: Gremlins - the film. The best liquidiser gag in the biz
- 5 Director: Stephen Spielberg. I loved ET - but not as much as Gremlins which he only produced
- 6 TV: Lives and Loves of a She Devil. Fay Wheldon is brilliant!
- 7 Book: 'Salem's Lot by Stephen King. I've read it four times
- 8 Pub. The Metropolitan Cellar Bar. They do great beef burger
- 9 Disco. Flicks, Dartford. If you've been there you'll know why!
- 10 Food. Duck Pate - on lightly browned bread. Feeding it to the ducks is the best part

### Top 5 games of 1986

- 1 Dandy.

### Favourite 10 things in the universe

- 1 Movie of '86: Aliens
- 2 Video release: Repro Man or Birdy The lead actor in Repro Man is just so angry, and Harry Dean Stanton is about as cool as anyone over 30 could possibly be
- 3 LP: Talking Heads' "Stop Making Sense" "Burning Down the House" must be the best record ever
- 4 Tie: It's quite dark, with little black squares, and green and red bits and the occasional gold dot
- 5 Colour: Blue
- 6 Smell: creasote, check this spelling, David. (Looks wrong - Ed)
- 7 Place in London: Davies St/Berkeley Sq
- 8 Length of music tape: C90
- 9 Station: Baker Street tube
- 10 Car park: Kingston upon Thames NCP. You can get right up the top and the view is great.

# 1986. That's it?

About this time of year, what with the old year passing and a New Year just beginning we journalists like to reflect on what's gone before. It also gives each member of the crack **SU** team a chance for glory and fame quite out of keeping with their actual status in the world.

So we bring you, at great expense(s) the Sinclair personality Top Ten Best Things in the universe and more. . .

Not only that, you get a chance to vote for YOUR most favourite games, other things, real dodos etc in our 1986 Readers Poll - just turn back to page 68 . . .

- 2 Uridium.
- 3 Movie.
- 4 Heavy on The Magic.
- 5 Winter Games 128.

### Five of the worst things ever invented

- 1 The 8.14 from Albany Park to Cannon Street. Doncha just luv playing those operating difficulties. Game plans can be purchased at the ticket office - it's the window with the long queue in front of it
- 2 Bores. Especially telephone bores
- 3 Balloons. Sudden noises turn me homicidal
- 4 Sleep. I never get it so I don't miss it
- 5 Time Tables. You just know they're always going to be wrong but you look at them just the same.

John Gilbert



### Top 5 of 1986

- 1 Uridium
- 2 Lightforce
- 3 Thantos
- 4 Split Personalities
- 5 Firelord

### Five of the worst things ever invented

- 1 Crowds
- 2 The 'popular' press. No comment.
- 3 The £50 limit on cheques
- 4 Answerphones
- 5 Football

Jim Douglas

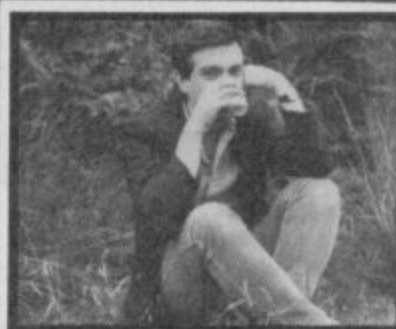

### Favourite 10 things in the Universe

- 1 Jeffery Archer's resignation.
- 2 Getting a walkman that worked properly.
- 3 Starglider. A game I would go out and buy. . .
- 4 Everything by Phillip Glass.

### Favourite ten things in the universe

- 1 Late night movies. Front row, wide screen, preferably SF - Bladerunner would do
- 2 Coffee.
- 3 Right now it's either The Walker Brothers or The Beastie Boys. Ella's OK too
- 4 Music videos - all of them. I wish they chained them end-to-end on all night TV.
- 5 Turning the sound right up.
- 6 Westerns. Especially the one's where the plot is really a metaphor etc etc yeah yeah. . .
- 7 Portable manual typewriters
- 8 Marston's Pedegree. I've spotted I'm the only one who's included any kind of booze in their ten. What does this mean - they're all liars
- 9 The Fiat whateveritis Spyder.
- 10 '30s style. Not a lot of progress since then really

### Top 5 games of '86

- 1 Glider Rider
- 2 Uridium
- 3 Head Coach
- 4 Ghosts 'n' Goblins
- 5 Anything by Delta 4

5 This really cheap Italian suit I found in a shop in Southend. You should see it it's really neat

6 Amstrad taking over Sinclair. Yeah I know, some people will disagree.

7 The Sinclair 128K+2 - if you can a) get one b) get one without a dodgy tape alignment or odd modulator. It's excellent

8 Playing with my CZ101 synth, now Midied to the CT6000.

9 "A large Souvlaki in pitta with a portion of chips and lot a chilli playse!"

10 Academy. See 3

### Top 5 games of 1986

- 1 Starglider.
- 2 Academy.
- 3 Lightforce.
- 4 Trapdoor.
- 5 Dandy.

### Five of the worst things ever invented

- 1 Any game with the word 'whacky' in it
- 2 Any adventure game with a magic orb in it
- 3 Car stickers.
- 4 Religious loonies with carrier bags
- 5 That advert with the total pillock who says "how's your ego?"

Graham Taylor

### Five of the worst things ever invented

- 1 Dealing with shops when things you buy go wrong. Comet has just lost my camera. . .
- 2 There's this stuff called Irn Bru which someone I know drinks. It's horrible
- 3 Those iron railings to stop you trying to cross the road where THEY don't want you to. Painfully spikey rocks set into the ground to stop you walking down the central reservation get my vote too
- 4 Sunshine. I'm convinced it's bad for you. Also health foods, sugar substitutes and exercise
- 5 And then there's war, violent crime, rape, political repression and human rights abuses. . .



David Kelly



# Putting your games software onto the streets

## Andrew Hewson explains how to begin your own mini games company

Anthony and John Poval of St Neots are putting me on the spot and for that I am sending them a copy of *Pyracurse* for this month's star letter. They write: We are writing a graphic adventure using Incentive's Graphic Adventure Creator. It is not exactly Level Nine stuff but we are hoping to sell it to one of the budget games companies. Can you give us some advice on selling the game, any precautions we should take, and idea of how much it would be worth and so forth?

Oooh! This is a difficult one for me. Far be it from me to



discourage people from writing software for sale but surely the first question that you must answer, Anthony and John, is

'Is your program worth anything at all? Would you spend your hard-earned cash on a program which the authors

themselves admit is written with a program creator and is 'not exactly Level Nine stuff'. Unless your honest answer is 'Yes you would spend your money to buy your own program' then you have no chance of convincing the rest of the world to part with their money for your program.

OK, you two, I'm convinced. You honestly believe that your program is worth spending money on. Now how are you going to sell it? For a start you have to realise that you are not the only people in the entire world who are beaver away with Incentive's **Graphic Adventure Creator** or its equivalents. You've decided to approach a budget software company. Realistically you have to realise that a large number of other people will be following the same path. How are you going to ensure that your game is the one that gets accepted for publication so that you get paid?

My advice is to make it as easy as possible for your target publisher to get to know your game. There are lots of little things you can do to help:

- Record your program several times on the cassette that you send off for evaluation - you don't want to fail because the publisher cannot load the game.
- Write a concise, business-like

## Astounding assembly

Kulwinder Singh of Isleworth writes to say lots of flattering things

Table 2. A Spectrum program to *Print* the characters with code in the range 32 to 255 inclusive. Note that when the a register contains 255, the effect of the *inc A* instruction is the same as subtracting 255, ie A subsequently contains zero

Decimal	Assembly Code	Comment
62 32	ld a,32	Load the A register with 32
245	Again push af	Save A on the stack
215	rst 16	Print the character
241	pop af	Retrieve A from the stack
60	inc a	Increment the A register
32 250	jr nz, Again	Jump to Print next character
201	ret	Return when A reaches zero

about Uridium which I won't repeat here. I'm glad you like it. One of my problems is tearing my programmers away from it - somehow they are always 'just testing' it, or 'checking that it works with the new Sproddoggy Wizzo joystick'. If they're really stuck for an excuse then it suddenly seems to be their lunch hour.

Kulwinder also says: I want to write a game which is just as good and I am starting to learn machine code but I have difficulty in printing on the screen. I know you can use *Call 3545* to set the X and Y coordinates and *Rst 16* to print but it doesn't work.

Doesn't work! Don't be daft, of course it works! That's how stuff gets *Printed* on the screen? There's no magic involved - just repeated use of *Rst 16*.

The procedure is simple once you get to know what's going on. First of all call the routine at

Table 1. A routine to print the letter "A" at the top left-hand corner of the Spectrum screen

Decimal	Assembly Code	Comment
62 2	ld a,2	Select the screen output stream
205 1 22	call 1601h	And call the routine to do it
6 24	ld b,18h	Select the top row
14 33	ld c,21h	Select the left-hand column
205 217 13	call Odd9h	And call the routine to do it
62 65	ld a,41h	Load A with the code for "A"
215	rst 10h	and call the routine to print it
201	ret	Bye-bye

5633 (1601 in hex) with register A set to the stream number of the output device that you wish to use. Normally you won't need to do this when writing to the screen because the Spectrum will already be set to write to the screen (as opposed to Microdrive or printer or whatever) but it is as well to do so just in case. The stream number for the screen is 2.

Next you can use the routine at 3545 (ODD9 in hex) to set the screen row and column positions at which printing is to occur. To do this load the B register with the screen row counting from the bottom (so that the top row is number 24) and the C register with the screen column starting with

Column 2 being at the extreme right (so that the extreme left column is number 33). Yes, I know it would make more sense to start at the top left-hand corner and label it Row 0, Column 0 but I didn't write the Spectrum Rom routines so don't blame me. If this sort of thing really upsets you why not write a little routine as a 'front end' which alters the B and C registers from what makes sense to what is required and then calls the Rom routine.

Having established that you want to write to the screen and set the area you want to write to you are now ready to print a character. Put the code of the required character into the A register and call *Rst 16* (10 in hex). Easy isn't it? The routine in Table 1 prints the letter "A" at the top left of the screen. The routine in Table 2 prints all the characters with codes lying between 32 and 255. Both of these routines can be loaded into the Spectrum printer buffer using the simple loader in Table 3.

Table 3. A simple decimal loader for *Pokeing* decimal numbers into the Spectrum printer buffer. To halt the program enter *Stop* (Symbol Shift A)

10	FOR I = 23296 TO 23551
20	INPUT J
30	POKE I, J
40	PRINT I, J
50	NEXT I

## A good clear-out

Thank you for the stamp, Stanley Gee of Leeds. Unfortunately I shan't be using it because I'm replying to you through the medium of this column. This means that the Post Office are going to be 13p better off than they would otherwise have been. Not much chance of getting your money back from the person at the till I suppose. However I digress. Stanley asks: **What is the difference between *Clear 30000* which sets RamTop to 30000 and *Poke 23730,48: Poke 23731,117* which changes the RamTop system variable directly? Also I note from time to time the command *Clear 65535* followed by a machine-code routine placed below this address. What purpose does this serve?**

The *Clear* command does a lot of other bits and pieces besides changing the RamTop system variable. First of all it throws away all current Basic variables so that if you have just *Run* a Basic program to store your mother's birthday in a variable called *Mum\$* you will



# HEWSON HELPLINE

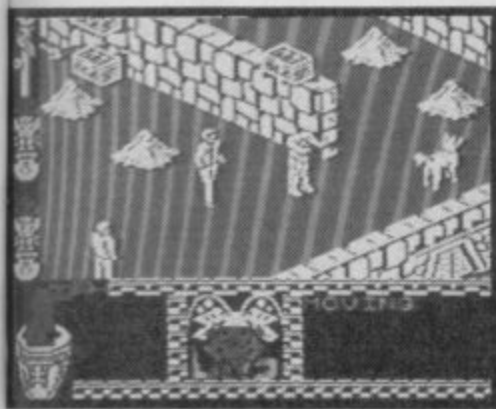

letter. Make sure your name, address and phone number are on the letter. Include a *brief* description of your game in the letter and explain which machines it runs on.

- Include a detailed explanation of the game in a separate document. Don't leave out the best bits with the idea that the publisher should be forced to play the game for hours to get a feel for it. Include a map and a list of cheats.
- If you are good at drawing, include a few sketches of the main visual parts of the game.
- If you have had other material published make sure you refer to it clearly in your letter and if your material has been reviewed include relevant photocopies.

find that after a *Clear* command the instruction *Print Mum\$* will no longer work. It also clears the screen display (like *Cls*) resetting the *Print* position to the top left-hand corner and the *Plot* position to the bottom left-hand corner. It rewinds all the *Data* and *Read* pointers in the manner of a *Restore* command and finally it changes *RamTop* and moves the *Gosub* stack so that it lies immediately below the new *RamTop* value.

*Clear* is quite a busy little command. Changing *RamTop* by *Poking* the system variable is a bit like moving into the house next door without telling the postman, the milkman or the newspaper boy. You may get away with it but the chances are you're going to create a bit of a muddle!

*Clear 65535* has the effect of giving you the maximum amount of room possible for your Basic programs. Why anyone should want to put a machine-code routine below *RamTop* is not immediately clear to me. All I can say is that it is a bit risky although you can get away with it provided you know what you are doing. In particular you must be careful where you put the machine stack.

● Above all, sell yourself! You say you feel the need to take precautions – presumably against your target publisher releasing the program without your knowledge and then refusing to pay you your dues. The first thing you need to be able to do if a dispute ever arises is to prove that you wrote the software in question. To do this you require an independent witness so why not deposit a copy of the program on cassette (or preferably several copies in case of accident) with a reputable independent organisation like your bank or solicitor.

If you don't have easy access to a bank or solicitor then simply post a copy of the program by registered post to yourself in a sealed envelope. The Post Office will automatically date stamp the envelope for you and providing you *don't open the envelope* when it arrives you will be able if necessary at some time in the future to open it in front of witnesses and prove that you possessed the program by a given date. Since you wrote the program and you have wisely not yet given anyone else access to it no-one will be able to prove that they had the program at an earlier date – which goes a good way towards proving that the program is yours.

A second simple precaution is only to approach a reputable publisher. You will be treated fairly if sometimes firmly (remember even if you and all your friends, relatives, neighbours, teachers, school mates and the local vicar all agree that your program is wonderful in all respects your target publisher is at liberty to disagree!

Finally, how much is your program worth? That is an impossible question to answer because it depends how good it is. Don't be misled by the stories of people making a fortune from writing software. With persistence and a healthy amount of commonsense you can earn a comfortable living along with the several tens of thousands other people in the country who all want to do the same thing. As a guide a first class computer program for the Spectrum written by an established team is probably worth about as much in advance as an ordinary family car but the budget program you are aiming at, Anthony and John, is probably worth much less – say as much as a five-year saloon with 60,000 miles on the clock! Good luck.

## Excuses!

Regular readers will remember the competition a month or two ago in which you were invited to send a photocopy of the very first *Helpline*. The winner has been and gone long since but Ian King of Chalfont St Giles takes the wooden spoon for the phoniest excuse for not getting his entry in on time. He claims to have been on holiday when **SU** was published !!! Frankly, Ian, this is simply not good enough. Write out one thousand times 'I must buy my copy of **SU** on time and read *Helpline* straight away.

Entries for the machine-code clock routine competition are still falling through the letterbox so I have had to defer publication of the winning program. Watch out for the result next month.



## Scrambled scrolling

Can you record a message scrolling across the Spectrum TV display on video tape? asks Terry Braverman of Cambridge. This seems to my imaginative but erstwhile sensible mind not to be possible. Also, if I do plug the aerial lead from my Spectrum into the video's aerial socket will the picture quality improve on my domestic TV? Common sense suggests that it won't.

Yes, you can record the Spectrum output on video tape. No, the picture quality is not improved – it is generally considerably worse.

As you will remember from your reading of the Spectrum manual, the Spectrum 'transmits' its UHF signal on channel 36 and so to 'receive' the transmission on your TV you must tune it to this channel number. True transmission and reception never occurs of course because you wire the Spectrum and TV together directly but there is no reason in principle why you should not put a transmission aerial on the end of your Spectrum aerial lead and broadcast to a neighbouring TV tuned to channel 36 – no reason except it's illegal of course!

Channel 36 is also used by most domestic video recorders to 'transmit' a recorded program to the TV. In order to record the Spectrum display choose a spare channel on your video recorder, plug the Spectrum aerial lead into the video input socket, connect the

video output socket to the TV input and tune the video input on the channel selected to Channel 36. It's as easy as that.

In the course of our work we occasionally record games in this fashion when we want to work out how a given game is driving the TV display. Our video recorder has a 'freeze frame' facility which allows you to step through a recorded video frame by frame. Using the facility we can work out interesting things like whether the software is synchronised to the TV display (these days the answer is usually that it is), how often the screen is updated (every frame, every other frame, every fifth frame etc), how many positions are used to make up each sprite, how efficient the collision detection is and how far in terms of pixels up and down, and left and right the main sprites are moved each time they are up-dated.

The picture quality is not as good as the original because it has to go through the transmission-reception rigmarole twice instead of once and in the middle it is recorded on to video tape and then played back. Each step leads to a loss of picture quality. In normal operation the picture is mixed with the Ultra High Frequency (UHF) carrier inside the Spectrum and then unmixed inside the TV. With a video in between the unmixing occurs in the video when recording takes place and then on playback the picture is remixed for 'transmission' to the TV.



## REVIEW

# GRAPHICS TOOLKIT

Pyramide's already launched a graphics program, hasn't it? Why the need for another one, and why do you need to design your pictures first before you can use the package?

Simple, *Graphic Toolkit* is not just another creaky old design package. It can store several screens at a time from which it can take or combine and manipulate images to produce some startling graphics effects.

The bulk of the package consists of 70 SuperBasic extensions which are loaded into the machine on boot-up.

You can set up windows, design pointer cursors which can be controlled using the keyboard, joystick or mouse, create and *Fill* shapes, draw on the screen using a width-

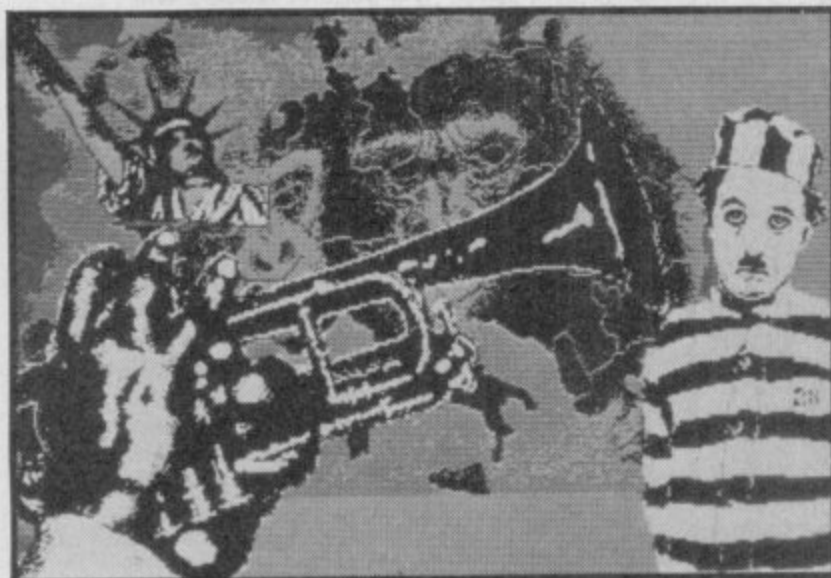

selectable airbrush and switch between the different display modes and the two character fonts with which all QLs are

born. You can also create your own character sets.

Three programs are included to show what the **Toolkit** routines can do. The first, *Transfer\_X* allows you to cut out and copy images from screen to screen.

You can also cut around images. Images can be stacked one on top of another and when

### FACTS BOX

A fabulous image-making aid, but you'll need a graphics package in order to create the images

#### GRAPHICS TOOLKIT

Label: Pyramide

Price: £14.95

Memory: 128K/256K

Joystick: any, also mouse compatible

Reviewer: *John Galbot*



you rub part of the top picture out the image beneath it reappears.

The second demo program, *Zoom Bas*, is written in SuperBasic and shows how to magnify a pixel block 28x20 by 16 times. *Definer\_Bas*, the third program, also written in SuperBasic, is a simple character generator which can produce two character fonts for each screen channel.

**Graphics Toolkit** is almost useless to someone who doesn't have the means to generate images but it is incredibly powerful for anyone with any graphics package and the know-how to produce good art.

# BETTER BASIC

subroutine which does the same task but uses different code.

If your program contains dramatic errors even **Better Basic** will not be able to cope. For instance you may have included too many *For* statements and not enough *Nexts*. **Better Basic** would run through the whole program, note the mistakes and give you a list of them at the end of the scan.

SuperBasic is a complex language and if you intend to take full advantage of it, and avoid the bugs, you'll either need to spend hours pouring over your programs or buy **Better Basic**.

SuperBasic is a fantastic high level language but even the most adept Basic programmer may find the structure could be improved. A *Renumber* here, a tweak there...

**Better Basic** does the tweaking automatically and is unique to the QL. It will not only renumber your program but will also improve its structure and, if necessary, create new lines to deal with certain functions in a more stylish or efficient manner.

The system operates in a similar way to a compiler. You create your Basic source program, load **Better Basic**, and feed it with the source which is then changed. Once the changes have been made the source is re-stored as a new file.

The **Better Basic** operating system can change the structure of your program within pre-defined limits. For instance, it may split up a long line of statements into separate lines to make them easier to read or, more drastically, exchange a long line into a

### FACTS BOX

*It's no panacea, but Better Basic will point out the bugs in both the code and structure of your program as such its really useful*

**BETTER BASIC**  
Label: Digital Precision  
Author: Charles Dillon  
Price: £19.95  
Memory: 128K

Reviewer: *John Galbot*



# QLIBERATOR

Liberation Software, a new company, claims to have developed the definitive SuperBasic compiler.

The specification certainly looks impressive on paper but, to be equal to its claim, it will have to beat Digital Precision's new **Turbo Compiler** on speed and facilities.

Accurate timings on **Turbo** are, unfortunately, impossible to get as the program is still going through its testing phase.

However, **Turbo** compiles to full 68000 code while **QLiberator** only uses a form of P-code which is interpreted by the run-time system.

Once you look at features, though, the two packages are fairly evenly balanced.

**QLiberator** will compile all SuperBasic programs, and there's no code limit so you can add memory board and external storage devices - such as discs - with little or no change to the program.

Liberation's program works in a similar way to **Turbo** but is simpler to use. When you boot it up a set of SuperBasic command extensions are loaded into memory. You can then either load and edit the SuperBasic program or invoke the compiler with one command.

The *lvoke* command is

### FACTS BOX

*At last, a compiler which everyone can understand. Compiles all SuperBasic source code, but to P-code*

#### QLIBERATOR

Label: Liberation Software,  
43 Clifton Road, Kingston Upon Thames,  
Surrey

Price: £69.95

Memory: 128K/512K

Reviewer: *John Galbot*



*Liberate Mdv1* followed by the file name of the source. This command will run through the compilation process automatically and store the resulting object code back on the Mdv1 with the suffix *Ob/f/*.

**QLiberator** is a powerful SuperBasic compiler which will handle any correct source code given to it. The compiler is simpler to use than DP's **Turbo** but does not have the latter's complexity. It will be good for intermediate level SuperBasic programmers who want a no fussing way of doubling the speed of their software.

# COP-OUT

**Mikro**  
GEN

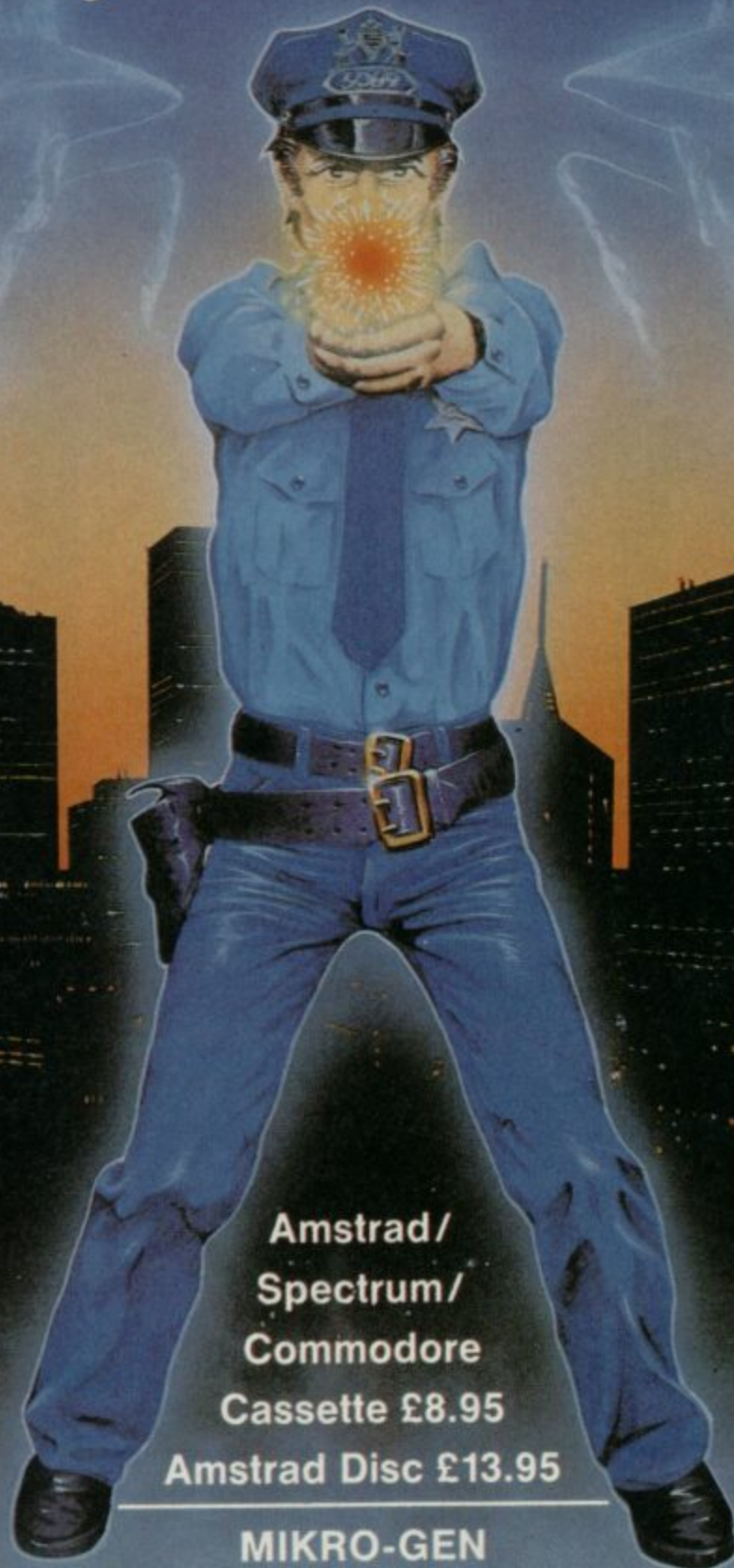

Amstrad/  
Spectrum/  
Commodore  
Cassette £8.95  
Amstrad Disc £13.95

MIKRO-GEN

Unit 15 The Western Centre Western Road Bracknell Berks.

# MASTERS GAMES

- (A) Spectrum 48K
- (B) CBM 64/128
- (C) Amstrad
- (D) C16 plus 4
- (E) Atari
- (F) BBC
- (G) Electron
- (H) MSX

Not For

## Unbelievable Ultimate

Jetpac  
Tranzam (A)

Lunar Jetman  
Pssst

Atic Atac  
Sabre Wolf (A)

Underworld  
Alien 8

Entombed  
Blackwyche (B)

Staff of Karnath  
Imhotep

Sabre Wolf  
Nightshades (C) £7.99

Jetpac  
Nightshades (F)

Knightlore  
Sabre Wolf

Alien 8  
Gunflight (H)

Knightlore  
Nightshades

## Arcade Classics

Pac Man  
Dug Dug (B)

Mr. Do!  
Pole Position

Pac Man  
Dug Dug (E)

Mr. Do!  
Pole Position

## War Game Greats

Tigers in the Snow  
Germany 1985 (B)

Combat Leader  
Knights of the  
Desert

## Big names Bonanza

Fight Night  
Stellar 7 (B)

Forbidden Forest  
Talladega

## Krazy Kids

Kermit  
Donald Duck (B)

Return to Oz  
Congo Bongo

All cassettes **£9.99** (Except Unbelievable Ultimate Amstrad £7.99)

At a time when you're being showered with cut price bargains, amazing value packs or stunning compilations (of games you've never heard of!), then it's hard to work out what is a good buy and what isn't. Cast off the confusion and look no more, for here we present a range of compilations of games that are classics in their own right, or have established pedigrees which guarantee their quality. Here we have compiled a series of products which stand as the master of any of its rivals.

# Ir-quality compilations

## Shoot 'Em Ups

Super Zaxxon  
Dropzone  
(B) (E)

Blue Max 2001  
Fort Apocalypse

## Amstrad Academy

Zorro  
Bruce Lee  
(C)

Dambusters  
Bounty Bob

## Spectrum Stingers

Bruce Lee  
Zorro  
(A)

Pole Position  
Cyberun

## Scott Adams Scoops

Voodoo Castle  
Strange Odyssey  
(A) (B) (C) (D)

Buckaroo Bonzai  
Pirate Adventure\*

Voodoo Castle  
Strange Odyssey  
(E) (F) (G) (H)

Buckaroo Bonzai  
Pirate Adventure\*

## Broderbund Blasters

Karateka  
Stealth  
(B)

Choplifter  
Spellunker

## Atari Aces

Zorro  
Up n Down  
(E)

Spy Hunter  
Tapper

## Platform Perfection

Zorro  
Bruce Lee  
(E)

Bounty Bob  
Ghostchaser

Zorro  
Bruce Lee  
(B)

Bounty Bob  
Ghostchaser

\* (Previously unreleased)

**Crime is a disease. He's the cure.**



**STALLONE**  
**COBRA**

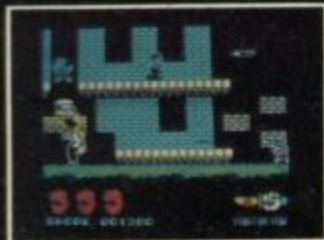

**ocean**

SPECTRUM  
**£7.95**

COMMODORE 64  
**£8.95**  
AMSTRAD

© 1986 Warner Bros. Inc.  
All rights reserved.

6 Central Street • Manchester M2 5NS  
Tel: 061 834 3939 • Telex: 669977

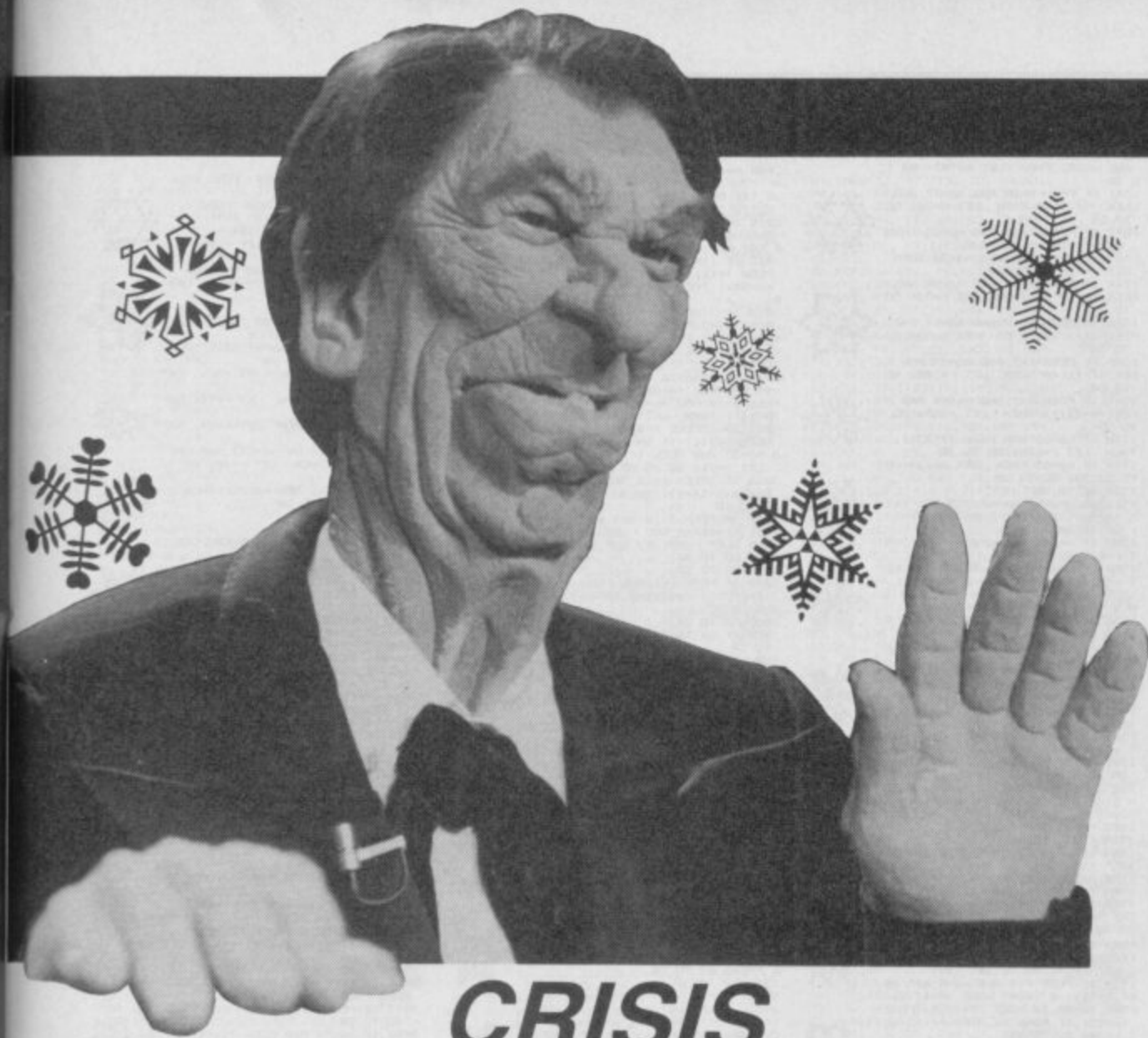

# CRISIS AT CHRISTMAS

TOM FROST

**A**ll is quiet in the peaceful land of Milton Keynes. In the black of night (9.30) the snow falls gently on to the elevated walkways. A red balloon falls from a neatly pruned birch tree on to the crisp, short, frost grass.

It's Christmas Eve, and everyone is asleep except you.

Crisis at Christmas – a yuletide adventure of mammoth proportions – lets you take the role of either Ron or Nancy – the ultimate Miltonions – in attempting to secure another idyllic and calm Christmas for your children.

Having received a call from your better half, informing you they won't be back from the white house (they're all white – it is snowing) to finish the present-wrapping, it is your responsibility to locate, wrap and position two remaining gifts.

Explore the locations in the adventure, following standard command routines (N for north, S for south etc).

## Typing in the game

You will need two cassettes.

- Type in Listing 1 and save using *Goto* 100 (put it at the start of Tape A)
- Type in Listing 2 and save using *Goto* 9990 (put this on Tape A, after Listing 1)
- Re-set computer
- Type in Listing 3 and enter the data from Listing 4, one number at a time. Follow the on-screen instructions to save this on Tape A after the Basic listing.
- *Goto* 9902 will now start the program but for safety, *Save* the whole lot on to Tape B using *Goto* 9990

### Listing 1

```
10 CLEAR 53484
20 BORDER 0: PAPER 0: INK 0: B
RIGHT 1: CLS
30 PRINT "PAPER 7: INK 2:AT 0,
5:" CHRISTMAS ADVENTURE "
40 PRINT INK 5:AT 13,4:"With
Seasonal Greetings
from Tom Frost."
50 LOAD ""
100 SAVE "loader" LINE 10
```

### Listing 2

```
5 REM listing 3
10 CLEAR 53484
15 BORDER 7: PAPER 7: INK 0: B
RIGHT 0: CLS
16 PRINT AT 0,4:"Press a key t
o start"
17 PAUSE 0
18 CLS
20 FOR s=53485 TO 65192
30 IF s=64062 THEN LET s=6442
0
40 POKE 23692,255
50 LET z=0
60 FOR y=1 TO 7
70 PRINT s:"1":....."
80 INPUT d
90 LET z=z+d
100 POKE s,d
110 PRINT d
120 LET s=s+1
130 NEXT y
140 INPUT c
150 IF c<>" THEN GO TO 200
155 LET s=s+1
160 NEXT s
170 CLS
180 PRINT AT 0,1:"Now SAVE afte
r
BASIC listing."
190 SAVE "SYSTEM CODE 53485,117
00
195 STOP
200 FOR b=1 TO 20: BEEP .05,b:
NEXT b: BEEP .5,20
210 PRINT "ERROR in previous s
input:.....Please enter the s
ain."
220 LET s=s-7
230 GO TO 20
240 SAVE "input" LINE 10
```

### Listing 3

```
10 POKE 23500,r: RANDOM
IZE USR PRM5: RETURN
20 LET r=15
30 POKE 23500,r: RANDOMIZE USR
PRM5
32 IF PEEK (f+12)=1 THEN PAUS
E 100: POKE (f+12),0: GO TO 100
35 GO TO 195
40 PRINT INK 5:AT 13,4:"With
Seasonal Greetings
from Tom Frost."
50 LOAD ""
100 BORDER 0: PAPER 0: INK 0: B
RIGHT 1: CLS
101 IF res=1 THEN GO SUB 0000:
LET res=0
102 GO SUB 7000+PEEK f+10
103 LET zz=f+PEEK f+40
105 IF (PEEK f+2 OR PEEK f+11)
THEN GO TO 195
110 RANDOMIZE USR PRM5
195 BEEP .1,20: RANDOMIZE USR 0
VS
202 LET vb=PEEK 64114
204 LET no=PEEK 64115
205 IF no=0 AND PEEK (f+29)=1 T
HEN LET no=21
220 IF vb=200 OR no=201 THEN 0
0 TO 20
230 IF (PEEK f+2 OR PEEK f+11)
AND 1+vb<0 AND vb<20 AND vb<70:
AND vb<16 AND vb<15 AND vb<36
) THEN LET r=26: GO TO 30
235 GO TO 1000+vb+100
1000 LET no=no+vb: POKE 64115,n
o
1002 IF PEEK f+14 THEN GO TO 10
00
1004 IF PEEK (f+24)=1 AND PEEK (
f+21)=0 AND no=5 THEN LET r=75:
GO TO 30
1005 IF (PEEK (f+24)+PEEK (f+21)
<2) AND no=5 THEN LET r=75: GO
TO 30
1006 IF no=6 AND PEEK (f+24)=1 T
HEN POKE (f+24),0: POKE (f+12),
1: LET r=80: GO TO 30
1008 POKE (f+24),0
1009 IF (PEEK f+15 AND no=3) OR
(PEEK f+16 AND no=4) AND PEEK
(f+32)=0 THEN LET r=101: GO TO
30
1090 RANDOMIZE USR 65005
1092 IF PEEK 64115=0 THEN LET r
=13: GO TO 30
1093 POKE f,PEEK 64115
1094 GO TO 100
1100 IF no=29 THEN GO TO 1150
1102 IF PEEK f+1 AND no=54 THEN
LET r=14: GO TO 30
1104 IF PEEK f+12 AND no=55 THEN
LET r=14: GO TO 30
1106 IF PEEK f+5 AND no=38 THEN
LET r=19: GO TO 30
1108 IF PEEK f+19 AND no=43 THEN
LET r=20: GO TO 30
1110 IF PEEK f+18 AND no=52 THEN
LET r=19: GO TO 30
1112 IF PEEK f+17 AND no=40 THEN
LET r=20: GO TO 30
1114 IF PEEK f+3 AND (no=25 OR n
o=34) THEN LET r=20: GO TO 30
1116 IF no=40 THEN LET r=109: 0
0 TO 30
1140 GO TO 20
1150 IF PEEK (a+no)=99 THEN LET
r=17: GO TO 30
1151 IF PEEK f+10 AND no=20 AND
PEEK (f+26)=0 THEN POKE (f+26),
1: POKE (a+20),10: LET r=23: GO
SUB 10: LET r=57: GO SUB 10
1152 IF PEEK (a+no)<PEEK f THEN
LET r=16: GO TO 30
1153 IF PEEK f+4 AND PEEK (f+24)
=1 AND no=4 THEN LET r=20: GO 5
UB 10: LET r=52: GO TO 30
1154 IF PEEK f+9 AND PEEK (f+24)
=1 THEN LET r=103: GO TO 30
```

1155 IF (no=4 OR no=25) AND PEEK (+4)=0 THEN LET r=14: GO TO 3  
1156 IF (no=4 OR no=25) AND PEEK (+4)=99 THEN LET r=18: GO TO 3  
1158 IF (PEEK (a+4)=99 OR PEEK (a+25)=99) THEN LET r=48: GO TO 3  
1160 IF ((no=22 AND PEEK f=8) OR (no=23 AND PEEK f=6)) THEN LET r=20: GO TO 3  
1180 IF PEEK (+99)=MAX THEN LET r=20: GO TO 3  
1181 IF PEEK f=3 AND PEEK (+29)=0 AND no=8 THEN POK E (+29),1: POK E (a+8),0: POK E (+9),1: LET no=21  
1182 POK E (a+no),99: POK E (+99),1: POK E (+99)+1: POK E 22,PEEK 22-1  
1185 IF r=57 THEN GO TO 195  
1186 LET r=23: GO TO 3  
1200 IF no=68 THEN GO TO 1248  
1201 IF no=28 THEN LET r=20: GO TO 3  
1202 IF PEEK (a+no)<99 THEN LET r=17: GO TO 3  
1204 IF no<27 THEN GO TO 1220  
1205 IF PEEK 22=6 THEN LET r=11: GO TO 3  
1206 POK E (a+27),0: POK E (a+6),P E E K f: POK E (+6),0: POK E (+99),PEEK (+99)-1: POK E 22,PEEK 22-1  
1208 IF PEEK f=1 THEN POK E f,2: POK E (+12),1  
1210 IF PEEK f=12 THEN POK E f,1: 1: POK E (+12),1  
1212 LET r=22: GO TO 3  
1220 IF (no=24 OR no=28) THEN L ET r=20: GO SUB 10: LET r=58: GO TO 3  
1222 IF (no=22 OR no=23) THEN G O TO 4200  
1224 IF PEEK 22=6 THEN LET r=11: GO TO 3  
1230 POK E (a+no),PEEK f: POK E (+99),PEEK (+99)-1: POK E 22,PEEK 22-1: LET r=22: GO TO 3  
1240 IF PEEK (+99)=0 THEN LET r=20: GO SUB 10: LET r=100: GO T O 3  
1241 IF (PEEK f=6 OR PEEK f=8) T HEN LET r=11: GO TO 3  
1242 IF PEEK (a+27)=99 AND (PEEK f=1 OR PEEK f=12) THEN GO TO 1 206  
1246 IF PEEK (a+27)=99 THEN POK E (a+27),0: POK E (+6),0: POK E (+6),99: LET r=22: GO SUB 10  
1248 IF PEEK (a+26)=99 THEN POK E (a+26),0: POK E (a+5),99: POK E (+5),0  
1250 FOR x=1 TO 23: IF (PEEK 22)=6 AND PEEK (a+x)=99 THEN LET r=23: LET r=11: POK E (+12),1: GO TO 3  
1251 IF PEEK (a+x)=99 THEN POK E (a+x),PEEK f: POK E (+99),PEEK (+99)-1: POK E 22,PEEK 22-1  
1256 NEXT x  
1258 LET r=11: GO TO 3  
1300 IF no<29 THEN GO TO 1352  
1302 IF PEEK f=17 AND no=48 AND PEEK (+25)=0 THEN POK E (+25),1: POK E (a+10),17: LET r=56: GO TO 3  
1305 IF PEEK f=17 AND no=48 THEN LET r=48: GO TO 3  
1304 IF PEEK f=5 AND no=49 AND P E E K (+13)=0 AND PEEK (+31)=0 T HEN POK E (+31),1: POK E (a+3),3: POK E 22,PEEK 22-1: LET r=35: G O TO 3  
1305 IF PEEK f=3 AND no=49 AND P E E K (+31)=1 THEN LET r=48: GO T O 3  
1306 IF PEEK f=3 AND no=33 AND P E E K (+20)=0 THEN POK E (+20),1: POK E (a+5),3: POK E 22,PEEK 22-1: LET r=36: GO TO 3  
1307 IF PEEK f=3 AND no=33 THEN LET r=48: GO TO 3  
1308 IF PEEK f=12 AND no=55 AND PEEK (+17)=0 THEN LET r=41: GO TO 3  
1309 IF PEEK f=12 AND no=55 THEN LET r=59: GO TO 3  
1310 IF PEEK f=10 AND (no=56 OR no=32) AND PEEK (+26)=0 THEN L ET r=95: GO TO 3  
1312 IF PEEK f=19 AND no=43 AND PEEK (+27)=0 THEN POK E (+27),1: POK E (a+19),19: LET r=58: GO TO 3  
1313 IF PEEK f=19 AND no=43 THEN LET r=48: GO TO 3  
1314 IF PEEK f=1 AND no=54 AND P E E K (+11)=0 THEN LET r=72: GO T O 3  
1316 IF PEEK f=1 AND no=54 THEN LET r=59: GO TO 3  
1318 IF PEEK f=3 AND no=34 AND P E E K (+13)=0 THEN LET r=68: GO T O 3  
1320 IF PEEK f=3 AND no=34 THEN LET r=34: GO TO 3  
1322 IF PEEK f=16 AND no=46 THEN LET r=61: GO TO 3  
1325 IF PEEK f=10 AND no=51 AND PEEK (+26)=0 THEN LET r=75: GO T O 3  
1324 IF PEEK f=10 AND no=51 AND PEEK (+28)=0 THEN LET r=62: GO T O 3  
1326 IF PEEK f=10 AND no=51 THEN LET r=59: GO TO 3  
1328 IF no=32 AND (PEEK f<16 A ND PEEK f<10) THEN LET r=94: POK E (+12),1: GO TO 3  
1330 IF (no=30 AND (PEEK f=4 OR PEEK f=7)) OR (no=29 AND PEEK f=1) OR (no=29 AND PEEK f=12) T HEN LET r=94: POK E (+12),1: G O TO 3  
1332 IF (no=48 AND PEEK f=13) O R (no=41 AND PEEK f=14) OR no=44 AND PEEK f=19) THEN LET r=94: POK E (+12),1: GO TO 3  
1334 IF (no=58 AND PEEK f=5) OR (no=56 AND PEEK f=10) OR (no=45 AND PEEK f=10) OR (no=47 AND P E E K (+17)) THEN LET r=94: POK E (+12),1: GO TO 3  
1336 IF (PEEK f=6 AND no=36) OR (PEEK f=8 AND no=37) THEN LET r=96: GO TO 3  
1338 IF (PEEK f=15 OR PEEK f=16) AND no=53 AND PEEK (+32)=0 T HEN LET r=101: GO TO 3  
1340 IF (PEEK f=15 OR PEEK f=16)



AND no=53 THEN LET r=102: GO T O 3  
1341 IF PEEK f=10 AND no=52 AND PEEK (+19)=0 THEN LET r=72: GO TO 3  
1342 IF PEEK f=10 AND no=52 THEN LET r=42: GO TO 3  
1343 IF PEEK f=5 AND no=38 THEN LET r=72: GO TO 3  
1344 IF PEEK f=12 AND no=59 AND PEEK (+17)=0 THEN LET r=54: GO TO 3  
1345 IF PEEK f=12 AND no=59 AND PEEK (+17)=1 THEN LET r=54: GO TO 3  
1346 IF PEEK f=1 AND no=59 AND P E E K (+11)=0 THEN LET r=100: G O TO 3  
1347 IF PEEK f=1 AND no=59 AND P E E K (+11)=1 THEN LET r=59: GO TO 3  
1348 IF no=61 AND PEEK (+22)=1 THEN LET r=113: GO TO 3  
1349 IF no=61 THEN LET r=114+PE E K 23290: GO TO 3  
1351 GO TO 20  
1352 IF (PEEK (a+no)<99 AND PEE K (a+no)>PEEK f) THEN LET r=75: 1: GO TO 3  
1353 IF (no=8 OR no=21) THEN L E T r=81: GO TO 3  
1354 IF (no=7 OR no=28) THEN L E T r=93: GO TO 3  
1356 IF no=6 AND PEEK (+10)=0 T HEN LET r=25: GO TO 3  
1358 IF no=17 THEN LET r=105: G O TO 3  
1360 IF no=18 THEN LET r=106: G O TO 3  
1368 LET r=72: GO TO 3  
1400 IF PEEK f=4 AND no=5+POB T HEN LET r=51: GO TO 3  
1402 GO TO 100  
1500 CLS  
1501 IF PEEK (+22)=1 THEN PRIN T AT 4,1: LET r=116: GO SUB 10  
1502 PRINT AT 6,0: RANDOMIZE USR PRCAR  
1503 PRINT PAPER 1: INK 7: FLAS H 1: AT 21,3: Press a key to con tinue  
1504 PAUSE 10: PAUSE 0  
1514 GO TO 100  
1602 LET r=1: RANDOMIZE USR OU IT  
1700 RANDOMIZE USR SA  
1800 RANDOMIZE USR LD  
1900 IF PEEK f=1 AND no=54 AND P E E K (+11)=0 THEN LET r=58: GO T O 3  
1902 IF PEEK f=3 AND no=34 AND P E E K (+13)=0 THEN POK E (+13),1: LET r=24: GO TO 3  
1904 IF PEEK f=3 AND no=4 AND P E E K (+29)=0 THEN POK E (+4),1: POK E (a+8),3: POK E (a+4),0: POK E (a+25),3: POK E 22,PEEK 22-1: L E T r=30: GO TO 3  
1905 IF no=4 AND (PEEK (a+4)=99 OR PEEK (a+4)=PEEK f) THEN LET r=71: GO TO 3  
1906 IF no=25 AND (PEEK (a+25)=9 9 OR PEEK (a+25)=PEEK f) THEN L ET r=59: GO TO 3  
1908 IF PEEK f=5 AND no=38 AND P E E K (+16)=0 THEN POK E (+16),1: POK E (a+11),5: LET r=31: GO TO 3  
1909 IF no=4 AND PEEK (a+4)=PEEK f AND PEEK (+29)=1 THEN POK E (+4),1: POK E (a+4),0: POK E (a+2 5),PEEK f: LET r=23: GO TO 3  
1910 IF PEEK f=10 AND no=52 AND PEEK (+19)=0 THEN POK E (+19),1: POK E (a+18),18: LET r=33: GO TO 3  
1912 IF no=5 AND PEEK (a+5)=99 A ND PEEK (a+5)=0 THEN POK E (+5),1: POK E (a+5),0: POK E (a+26),P E E K f: POK E (a+9),99: POK E 22,PE E K 22-1: LET r=47: GO TO 3  
1914 IF no=5 AND PEEK (a+5)=PEEK f AND PEEK (a+5)=0 THEN POK E (+5),1: POK E (a+5),0: POK E (a+26),PEEK f: POK E (a+9),PEEK f: POK E 22,PEEK 22-1: LET r=29: GO TO 3  
1915 IF PEEK f=10 AND no=51 AND PEEK (+26)=0 THEN LET r=75: GO TO 3  
1916 IF PEEK f=10 AND no=51 AND PEEK (+20)=0 THEN POK E (+20),1: POK E (a+16),16: LET r=63: GO TO 3  
1918 IF PEEK f=10 AND no=51 THEN LET r=59: GO TO 3  
1920 IF PEEK f=4 AND no=58 AND P E E K (+24)=0 THEN LET r=70: GO T O 3  
1922 IF PEEK f=4 AND no=58 AND P E E K (+21)=0 THEN POK E (+21),1: LET r=23: GO SUB 30: LET r=46: G O TO 3  
1924 IF PEEK f=4 AND no=58 THEN LET r=20: GO SUB 10: LET r=59: G O TO 3  
1926 IF PEEK f=12 AND (no=55 OR no=57) AND PEEK (+17)=0 AND PEE K (a+10)=99 THEN LET r=73: GO T O 3  
1928 IF PEEK f=12 AND (no=55 OR no=57) AND PEEK (+17)=1 AND PEE K (a+10)=99 THEN POK E (+17),1: POK E (a+2),12: LET r=74: GO TO 3  
1930 IF PEEK f=12 AND (no=55 OR no=57) THEN LET r=59: GO TO 3  
1932 IF no=19 AND PEEK (a+no)=99 THEN GO TO 3400  
1934 IF (PEEK f=15 OR PEEK f=16) AND no=53 AND PEEK (+32)=0 T HEN LET r=102: GO TO 3  
1936 IF (PEEK f=15 OR PEEK f=16) AND no=53 THEN LET r=20: GO S U B 10: LET r=102: GO TO 3  
1938 IF PEEK f=19 AND no=51 T HEN LET r=85: GO SUB 10: PAUSE 80: LET r=86: GO TO 3  
1998 GO TO 20  
2000 IF no=25 AND PEEK (a+25)=99 THEN POK E (+4),0: POK E (a+25),0: POK E (a+4),99: LET r=23: GO TO 3  
2004 IF no=25 AND PEEK (a+25)=PE E K f THEN POK E (+4),0: POK E (a+25),0: POK E (a+4),PEEK f: LET r=23: GO TO 2000  
2006 IF no=4 AND (PEEK (a+4)=99 OR PEEK (a+4)=PEEK f) THEN LET r=20: GO TO 3  
2008 IF (PEEK f=15 OR PEEK f=16)



AND no=53 AND PEEK (+32)=1 T HEN POK E (+32),0: LET r=23: GO S U B 10: POK E (+12),1: LET r=101: G O TO 3  
2010 IF (PEEK f=15 OR PEEK f=16) AND no=53 THEN LET r=20: GO S U B 10: LET r=101: GO TO 3  
2012 IF ((PEEK f=1 AND no=54 AND PEEK (+11)=1) OR (PEEK f=1 AND no=58)) THEN LET r=71: GO TO 3  
2013 IF ((PEEK f=4 AND no=58 AND PEEK (+21)=1 AND PEEK (+24)=1) OR (PEEK f=3 AND no=34 AND PEE K (+13)=1)) THEN LET r=71: GO TO 3  
2014 IF ((no=26 AND (PEEK (a+no)=99 OR PEEK (a+no)=PEEK f)) OR (PEEK f=10 AND no=51 AND PEEK (+20)=1)) THEN LET r=71: GO TO 3  
2015 IF ((PEEK f=5 AND no=38 AND PEEK (+16)=1) OR (PEEK f=18 AND no=52 AND PEEK (+19)=1)) THEN LET r=71: GO TO 3  
2016 IF (PEEK f=12 AND no=55 AND PEEK (+17)=1) THEN LET r=71: G O TO 3  
2017 IF PEEK f=10 AND no=51 AND PEEK (+26)=1 AND PEEK (+28)=0 THEN LET r=20: GO SUB 10: LET r=60: GO TO 3  
2018 GO TO 20  
2020 IF PEEK f=3 AND PEEK (a+8)=3 AND PEEK (+29)=0 THEN POK E (a+8),0  
2022 GO TO 3  
2100 IF no=28 THEN LET r=20: GO TO 3  
2102 IF ((no=24 OR no=28) OR (no=11 AND PEEK (+22)=1)) THEN L E T r=48: GO TO 3  
2104 IF no=11 AND PEEK (a+11)<9 9 THEN LET r=17: GO TO 3  
2106 IF (no=11 AND PEEK 64107<6 7) THEN LET r=49: GO TO 3  
2108 IF (no<3 AND no<27 AND no< 21 AND no<20) THEN LET r=20: G O TO 3  
2109 IF PEEK (a+no)<99 THEN L E T r=17: GO TO 3  
2110 IF no=3 THEN POK E (+3),1: POK E (a+3),0: POK E (a+24),99: P O K E (+99),PEEK (+99)-1: POK E (+23),PEEK (+23)+1: LET r=27: G O TO 3  
2112 IF no=7 THEN POK E (+7),1: POK E (a+7),0: POK E (a+20),99: P O K E (+99),PEEK (+99)-1: POK E (+23),PEEK (+23)+1: LET r=23: G O TO 3  
2114 IF (no=21 OR no=28) THEN L ET r=85: GO SUB 10: PAUSE 50: L E T r=86: GO TO 3  
2116 GO TO 20  
2400 IF PEEK f=3 AND (no=31 OR n o=32) THEN LET r=87: GO TO 3  
2402 IF ((PEEK f=12 AND no=55) O R (PEEK f=1 AND no=54) OR (PEEK f=19 AND no=43)) THEN LET r=87: G O TO 3  
2404 IF (no=4 OR no=25) AND PEEK (a+no)=PEEK f THEN LET r=87: G O TO 3  
2405 IF PEEK f=10 AND no=20 AND PEEK (+26)=0 THEN POK E (+26),1: POK E (a+20),10: LET r=23: GO S U B 10: LET r=57: GO TO 3  
2406 GO TO 20  
2500 IF (no=4 OR no=25) THEN GO TO 4100  
2501 IF PEEK f=4 AND no=POB+5 A ND PEEK (a+4)=4 AND PEEK (+24)=0 THEN LET r=4: GO TO 4100  
2502 IF (PEEK f<20 AND PEEK f<12) AND no=35 THEN LET r=20: GO TO 3  
2504 IF no=(POB+6) THEN GO TO 1 000  
2506 IF no=95 THEN LET r=98: GO TO 3  
2508 LET no=(POB+5): GO TO 1000  
2600 IF (no<35 AND no<36) THEN GO TO 20  
2602 IF no=35 AND (PEEK f<4 AND PEEK f<10) THEN LET r=20: G O TO 3  
2604 IF PEEK f=4 AND PEEK (+24)=1 AND (no=4 OR no=8) THEN POK E (+24),0: POK E (+12),1: LET r=80: GO TO 3  
2606 LET no=(POB+6): GO TO 1000  
2700 LET no<11 THEN LET r=20: G O TO 3  
2702 IF PEEK (a+11)<99 THEN L E T r=17: GO TO 3  
2704 IF PEEK (+22)=1 THEN LET r=40: GO TO 3  
2706 POK E (+23),PEEK (+23)+1: POK E (+22),1: LET r=89: GO SUB 10: PAUSE 30: LET r=20: GO TO 3  
2800 IF no=28 THEN LET r=20: G O TO 3  
2802 IF PEEK (a+16)<99 THEN L E T r=80: GO TO 3  
2804 IF (no=17 OR no=18) AND PEE K (a+no)=99 THEN LET r=84: GO T O 3  
2806 IF no=21 AND PEEK (a+21)=99 THEN LET r=82+PEEK 23290: GO T O 3  
2808 GO TO 20  
2900 IF no<15 THEN LET r=20: G O TO 3  
2902 IF PEEK (a+15)<99 THEN L E T r=17: GO TO 3  
2904 IF PEEK (a+6)<99 THEN LET r=15: GO TO 3  
2906 POK E (a+15),0: POK E (+10),1: POK E (+99),PEEK (+99)-1: L E T r=23: GO TO 3  
3000 IF no=27 AND PEEK (a+27)=99 THEN LET r=24: GO TO 3  
3001 IF no=6 AND PEEK (a+6)<99 THEN LET r=17: GO TO 3  
3002 IF no=6 AND PEEK (a+10)=0 T HEN LET r=25: GO TO 3  
3003 IF no<6 THEN LET r=20: GO T O 3  
3004 IF no=8 THEN POK E (+6),1: POK E (a+6),0: POK E (a+27),99  
3006 IF PEEK f=2 THEN POK E f,1: GO TO 100  
3008 IF PEEK f=11 THEN POK E f,1 2: GO TO 100  
3010 LET r=21: GO TO 3  
3100 IF no=6 AND PEEK (a+6)=99 T HEN LET r=36: GO TO 3  
3102 IF no=6 THEN LET r=17: GO TO 3  
3104 IF no<27 THEN LET r=20: G O TO 3  
3106 POK E (+6),0: POK E (a+6),99

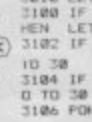

1: POK E (a+27),0  
3108 IF PEEK f=1 THEN POK E f,2: GO TO 100  
3110 IF PEEK f=12 THEN POK E f,1: 1: GO TO 100  
3112 LET r=23: GO TO 3  
3200 IF no=96 THEN LET r=99: GO TO 3  
3202 IF no=28 THEN GO TO 1300  
3204 IF PEEK (a+no)=99 THEN LET r=100: GO TO 3  
3206 GO TO 20  
3300 LET r=85: GO SUB 10: PAUSE 50: LET r=86: GO TO 3  
3400 IF (no<14 AND no<19) THEN LET r=20: GO TO 3  
3402 IF PEEK (a+no)<99 THEN L E T r=17: GO TO 3  
3404 IF no=14 THEN LET r=70: GO TO 3  
3406 IF no=19 THEN LET r=79: GO TO 3  
3500 IF (no=22 OR no=23) AND PEE K (a+no)=99 THEN LET r=48: GO T O 3  
3501 IF (no<1 AND no<2) THEN L E T r=20: GO TO 3  
3502 LET yy=8  
3503 FOR x=16 TO 18  
3504 IF PEEK (a+x)=99 THEN LET yy=yy+1  
3505 NEXT x  
3506 IF yy=3 THEN GO TO 3520  
3507 IF PEEK (a+no)<99 THEN L E T r=17: GO TO 3  
3508 LET r=75: GO SUB 10  
3509 IF yy=0 THEN GO TO 195  
3510 IF PEEK (a+17)<99 THEN L E T r=76: PEEK .5,20: GO SUB 10  
3512 IF PEEK (a+18)<99 THEN L E T r=77: PEEK .5,20: GO SUB 10  
3514 IF PEEK (a+16)<99 THEN L E T r=88: PEEK .5,20: GO SUB 10  
3516 GO TO 195  
3520 IF PEEK (a+no)<99 THEN L E T r=17: GO TO 3  
3524 IF no=1 THEN POK E (a+1),0: POK E (+11),1: POK E (a+22),99: L ET r=89: GO SUB 10: PAUSE 20: L E T r=91: GO TO 3  
3526 IF no=2 THEN POK E (a+2),0: POK E (a+23),99: POK E (+2),1: L ET r=89: GO SUB 10: PAUSE 20: L E T r=92: GO TO 3  
3530 GO TO 20  
3600 IF no<12 THEN LET r=20: G O TO 3  
3602 IF PEEK (a+12)<99 THEN L E T r=17: GO TO 3  
3604 POK E (a+12),0: POK E (a+13),99: POK E (+13),1: LET r=23: G O TO 3  
3800 GO TO 20  
3900 IF PEEK f=12 AND no=55 THEN LET r=54: GO TO 3  
3902 IF PEEK f<3 THEN LET r=53: 1: GO TO 3  
3904 IF no=54 AND PEEK (+11)=0 AND PEEK (a+9)=99 THEN POK E (+11),1: POK E (a+1),1: LET r=32: G O TO 3  
3906 IF no=54 AND PEEK (+11)=0 AND PEEK (a+9)<99 THEN LET r=5 5: GO TO 3  
3908 GO TO 20  
4000 IF (no=11 AND PEEK 64107<6 7) THEN GO TO 20  
4001 IF (no=24 OR no=28) OR (n o=11 OR no=6) AND PEEK (+22)=1 ) THEN LET r=20: GO SUB 10: L E T r=58: GO TO 3  
4002 IF PEEK f=3 AND no=8 THEN POK E (+9),1: POK E (+29),1: POK E (a+8),0: POK E (a+21),3: LET r=117: GO TO 3  
4004 IF (no=3 OR no=7 OR no=11 AND PEEK (+22)=0) THEN LET r= 20: GO TO 3  
4006 GO TO 20  
4100 IF (no=4 OR no=25) AND PEEK (a+no)=99 THEN LET r=65: GO TO 3  
4102 IF (no=4 OR no=25) AND PEEK (a+no)<PEEK f THEN LET r=66: G O TO 3  
4104 IF no=25 THEN LET r=68: GO TO 3  
4106 IF no<4 THEN LET r=15: GO TO 3  
4108 IF PEEK f<4 THEN LET r=67: 1: GO TO 3  
4109 IF PEEK (+24)=0 THEN POK E (+24),1: LET r=69: POK E (+12),1: GO TO 3  
4110 LET r=48: GO SUB 10: LET r= 52: GO TO 3  
4200 IF (no<22 AND no<23) THEN GO TO 1200  
4202 IF PEEK (a+no)<99 THEN L E T r=17: GO TO 3  
4204 IF (no=22 AND PEEK f=6) OR (no=23 AND PEEK f=8) THEN L E T r=20: GO TO 3  
4206 IF PEEK f=6 AND no=23 THEN POK E (+30),PEEK (+30)+1: LET r=89: GO SUB 10  
4208 IF PEEK f=8 AND no=22 THEN POK E (+30),PEEK (+30)+1: L E T r=89: GO SUB 10  
4210 POK E (a+no),PEEK f: POK E (+99),PEEK (+99)-1  
4214 IF PEEK (+30)=2 THEN GO S U B 8200: PAUSE 50: CLS: PRINT A T 8,0: LET r=97: GO SUB 10: PAU S E 50: PRINT: PRINT: GO SUB 80 0: LET r=96: GO SUB 10: PAUSE 50: 1: GO TO 1502  
4216 IF (PEEK f=6 AND PEEK f=8 ) THEN LET r=23: GO TO 3  
4218 GO TO 195  
4500 IF PEEK f=12 AND no=57 OR no=55 THEN GO TO 1926  
4502 IF PEEK f=1 AND (no=57 OR n o=54) AND PEEK (+11)=0 AND PEEK (a+10)=99 THEN LET r=104: GO T O 3  
4504 GO TO 20  
4600 IF PEEK f=4 AND (no=4 OR n o=25) THEN GO TO 4100  
4602 IF no=35 THEN GO TO 2500  
4603 IF no=97 THEN LET no=POB+5: 1: GO TO 2500  
4604 GO TO 20  
4700 IF no=28 THEN LET r=20: G O TO 3  
4702 IF PEEK (a+no)<99 THEN L E T r=17: GO TO 3  
4704 LET r=187: GO TO 3  
4800 IF no=98 AND PEEK f=3 THEN LET r=87: GO TO 3  
4802 IF no<98 THEN GO TO 20  
4804 LET r=112: GO TO 3







# TASWORD 128

# TASWORD THREE

# TASWORD PLUS TWO

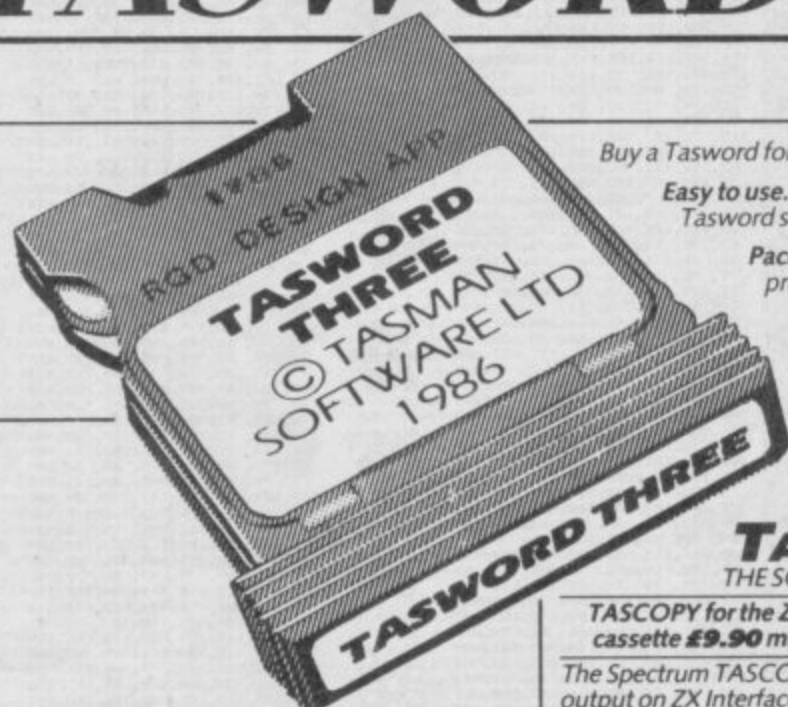

Buy a Tasword for your Spectrum and get a word processing program that is:

**Easy to use.** Just load the program and type in your text. If you do need help then it's there on the Tasword screen.

**Packed full of features.** The new generation of Taswords set a new standard in word processing on the Spectrum computers.

**Designed for YOUR computer.** There is a Tasword for each Spectrum computer. Each Tasword is designed to make the best use of the keyboard and memory on your Spectrum.

## ZX SPECTRUM TASWORD TWO THE WORD PROCESSOR

TASWORD TWO for the ZX 48K Spectrum  
cassette £13.90 microdrive cartridge £15.40

"Without doubt the best utility I have reviewed for the Spectrum"

HOME COMPUTING WEEKLY APRIL 1984

"If you have been looking for a word processor, then look no further"

CRASH JUNE 1984

With 64 characters per line on the screen and a host of useful features TASWORD TWO is the ideal cassette based word processing package for the Spectrum owner.

## TASPRINT THE STYLE WRITER

TASPRINT for the ZX 48K Spectrum  
cassette £9.90 microdrive cartridge £11.40

A must for dot matrix printer owners! Print your program output and listings in a choice of five impressive print styles. TASPRINT utilises the graphics capabilities of dot matrix printers to form, with a double pass of the printhead, output in a range of five fonts varying from the futuristic Data-Run to the hand writing simulation of Palace Script. A TASPRINT gives your output originality and style! The TASPRINT fonts are shown to the right together with a list of compatible printers.

## TASCOPY THE SCREEN COPIER

TASCOPY for the ZX Spectrum with Interface 1  
cassette £9.90 microdrive cartridge £11.40

The Spectrum TASCOPY is for use with the RS232 output on ZX Interface 1. It produces both monochrome (in a choice of two sizes) and large copies in which the different screen colours are printed as different shades. With TASCOPY you can keep a permanent and impressive record of your screen pictures and diagrams. A list of printers supported by TASCOPY is given to the left.

## TAS-DIARY THE ELECTRONIC DIARY

TAS-DIARY for the ZX 48K Spectrum and  
microdrives. Cassette £9.90

Keep an electronic day-to-day diary on microdrive! TAS-DIARY includes a clock, calendar, and a separate screen display for every day of the year. Invaluable for reminders, appointments, and for keeping a record of your day. The data for each month is stored as a separate microdrive file so that your data for a year is only constrained by the microdrive capacity. TAS-DIARY will work for this year, next year, and every year up to 2100! Supplied on cassette for automatic transfer to microdrive.

## TASMAN PRINTER INTERFACE

TASPRINT PRINTER INTERFACE for the  
ZX Spectrum £29.90  
RS232 Cable for ZX Interface 1 £14.50

Plug into your Spectrum and drive any printer fitted with the Centronics standard parallel interface. Supplied complete with ribbon cable and driving software. The user changeable interface software makes it easy to send control codes to your printer using the method so successfully pioneered with TASWORD TWO. The cassette contains fast machine code high resolution full width SCREEN COPY SOFTWARE for Epson, Mannesmann Tally, Shinwa, Star, Tandy Colour Graphic (in colour!) printers. TASCOPY shaded screen copy software for this interface (value £9.90) is INCLUDED in this package.

The TASCOPES and TASPRINTS drive all Epson compatible eight pin dot-matrix printers e.g.

AMSTRAD DMP 2000	NEC PC 80238-N	BROTHER M1009
EPSON FX-80	MANNESMANN TALLY MT-80	SHINWA CP-80
EPSON RX-80	STAR DMP 501/515/5610	DATA PANTHER
EPSON MX-80 TYPE III	COSMOS-80	DATA PANTHER II

**COMPACTA** - bold and heavy, good for emphasis  
**DATA-RUN** - a futuristic script  
**LECTURA LIGHT** - clean and pleasing to read  
**MEDIAN** - a serious business-like script  
**PALACE SCRIPT** - a distinctive flowing font  
TASPRINT output shown at less than half-size.

Compatible  
with Spectrum,  
Spectrum+, and  
128K Spectrum

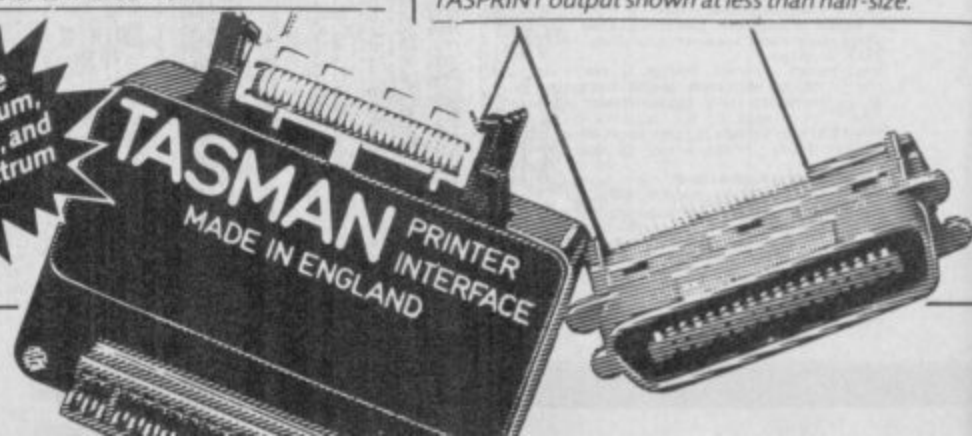



114,101,127, 99, 97,114,114,766  
121,105,110,103, 32,105,116,92  
32, 13,255, 16, 7, 60,111,503  
110, 39,116, 32,115,101,101,614  
32, 97,110, 32, 79, 84, 84,518  
79, 77, 65, 70, 32,104,101,526  
114,101, 32, 13,255, 16, 7,539  
89,111,117, 32, 99,105,105,661  
109, 98, 32,111,110, 32,116,608  
111, 32,116,104,101, 32, 79,576  
84, 84, 79, 77, 65, 70, 44,511  
32, 32, 32, 32,127, 97,110,467  
100, 32,114,101, 97,105,105,657  
115,101, 32,105,116, 32,119,620  
97,115, 32,117,115,101,105,685  
101,115,115, 32,115,111, 32,621  
32, 32,127, 99,105,105,109,612  
98, 32,100,111,115,110, 32,682  
97,103, 97, 83,117,114,101,693  
255, 16, 7, 83,117,114,101,693  
180,121, 32,110,111,116, 32,630  
119,104,101,110, 32,105,116,687  
32,105,115, 32,111,112,101,689  
110, 32, 13,255, 16, 7, 79,513  
75, 46, 46,121,111,117, 32,548  
99,105,105,109, 98, 32,111,662  
110, 32,116,111, 32,116,104,621  
101, 32, 79, 84, 84, 79, 77,536  
65, 70, 46, 13,255, 16, 7,480  
89,111,117, 32, 99, 97,110,655  
39,116, 32,114,101, 97, 99,590  
104, 32,105,116, 32, 13,255,658  
16, 7, 60,111,110, 39,116,467  
32, 98,111,116,104,101,114,676  
32, 97, 98,111,117,116, 32,683  
116,104, 97,116, 32, 13,255,734  
16, 7, 73,116, 39,115, 32,398  
106,117,115,116, 32,119,104,789  
97,116, 32,105,116, 32, 97,995  
112,112,101, 97,114,115, 32,683  
116,111, 32, 98,101, 46, 13,517  
255, 16, 7, 89,111,117, 39,634  
100,100, 32,110,101,101,100,648  
32,115,111,109,101, 32,115,618  
111,114,116, 32,111,102, 32,618  
116,111,111,100, 32,116,111,785  
127,100,111, 32,116,104, 97,687  
116, 32, 13,255, 16, 7, 89,529  
111,117, 32,109, 97,110, 97,673  
103,101, 32,116,111, 32,102,397  
111,114, 99,101, 32,105,116,678  
32,111,112,101,110, 32,119,617  
105,116,104,127,116,104,101,733  
32, 67, 72, 73, 83, 69, 76,472  
32, 97,110,100, 32,105,110,586  
115,105,100,101, 32,121,111,685  
117, 32,102,105,110,100, 32,598  
32,127, 97, 32, 83, 80, 69,520  
67, 84, 82, 85, 77, 46, 13,454  
255, 16, 7, 89,111,117, 32,627  
99, 97,110, 39,116, 32,100,593  
111, 32,116,104, 97,116, 32,680  
121,101,116, 46, 46, 46, 46,522  
46, 46, 46, 46, 13,255, 16,468  
7, 89,111,117, 32,104, 97,557  
118,101, 32,110,111, 32,119,623  
114, 97,112,112,105,110,103,753  
32, 80, 65, 80, 69, 82, 46,454  
13,255, 16, 7, 89,111,117,688  
32,104, 97,110,101, 32,110,594  
111, 32, 83, 84, 82, 73, 78,543  
71, 46, 13,255, 16, 7, 68,476  
69, 65, 82, 32, 70, 65, 84,467  
72, 69, 82, 32, 67, 72, 82,476  
73, 82, 84, 77, 65, 85, 44,589  
32, 32, 32, 32, 32, 32, 32,224  
32, 32, 32, 32, 84,104,105,516  
115, 32, 83, 72, 69, 82, 62,335  
89, 32,105,115, 32,102,111,586  
114, 32,121,111,117, 44, 32,571  
116,111, 32,116,104, 97,110,686  
107,127,32,111,117, 32,102,717  
111,114, 32,111,117,114, 32,631  
112,114,101,115,101,110,116,769  
115, 46, 32, 32, 32, 32, 32,321  
32, 32, 32, 32, 32, 32, 32,127,319  
32, 32, 32, 32, 32, 32, 74,266  
111,104,110, 32, 97,110,100,664  
32, 67,100, 97,114,101, 46,565  
32, 32, 88, 80, 80, 80, 13,429  
255, 16, 7, 89,111,117, 32,627  
114,101, 97,100, 32,111,110,665  
32,112, 97,103,101, 32,102,579  
111,114, 32, 50, 52,116,104,579  
32, 68, 69, 67, 42, 32, 32,332  
127, 66,111,121, 45, 68, 46,584  
46, 46, 46, 71,105,114, 100,536  
45, 85, 13,255, 16, 7, 79,500  
75, 46, 46, 46, 46, 46, 46,351  
46,121,111,117, 32, 99,100,634  
105,109, 98, 32,100,111,119,674  
110, 32,102,114,111,109, 32,610  
116,104,101,127, 79, 84, 84,695  
79, 77, 65, 70, 46, 13,255,613  
16, 7, 83, 99, 97,114,100,524  
101,116, 32, 97,110,100, 32,588  
99,111,115,121, 32, 13,255,747  
16, 7, 89,111,117, 39,114,493  
101, 32,119,105,102,101, 32,592  
119,111,117,100,100,110, 29,784  
116, 32,100,105,107,101, 32,601  
84, 72, 65, 84, 33, 13,255,686  
16, 7, 84,104,101,121, 32,465  
119,101,114,101, 32,101,120,688  
112,101,110,115,105,110,101,762  
46, 46, 98,101,116,116,101,624  
255, 16, 7, 84,104, 97,116,679  
39,115, 32,110,111,116, 32,555  
110,101, 99,101,115,115, 97,738  
71,121, 46, 13,255, 16, 7,572  
111,111,111,100, 32,105,100,620  
101, 97, 46, 46, 46, 46,46,420  
46, 13,255, 16, 7, 66,117,520  
116, 32,110,111,116, 32,103,620  
111,111,100, 32,101,110,111,676  
117,103,104, 33, 13,255, 16,641  
5, 79, 75, 46, 46, 100,111,462  
101,115,110, 39,116, 32,100,613  
111, 32,109,117, 99,104, 32,684  
103,111,111,100, 32,116,104,677  
111,117,103,104, 33, 13,255,736  
16, 7, 89,111,117, 32,100,476  
97,110,101, 32,110,111, 32,601  
83, 47, 73, 83, 83, 79, 82,550  
83, 46, 13,255, 16, 7, 87,587  
69, 76, 76, 32, 60, 79, 70,478  
69, 33, 13,255, 16, 5, 67,450  
100,105,109, 98, 32,119,104,675  
97,116, 32,111,114, 32,119,621  
104,101,114,101, 63, 13,255,751  
16, 7, 89,111,117, 32,110,482  
111,119, 32,104, 97,110,101,682  
32, 97, 32,119,101,100,100,597  
32,119,114, 97,112,112,101,687  
100, 32, 60, 79, 76, 76, 13,444  
255, 16, 7, 89,111,117, 32,627  
110,111,119, 32,104, 97,110,691  
101, 32, 97, 32,119,114, 97,591  
112,112,101,100, 32, 83, 80,620  
69, 67, 84, 82, 80, 77, 46,518



13,255, 16, 7, 76,111,110,588  
103, 32, 98,100, 97, 99,107,644  
32, 87,101,100,100,100,110,651  
103,116,111,110,115, 33, 13,681  
255, 16, 7, 79, 75, 46, 46,524  
46,121,111,117, 32, 99, 97,623  
110, 32,114,101, 97,100, 32,586  
105,116, 32, 97,103, 97,105,655  
110, 33, 13,255, 16, 7, 84,510  
104,101,114,101, 32,105,115,672  
32, 97, 32,119,104,105,116,605  
101, 32, 84, 79, 87, 69, 76,528  
32,100,121,105,110,103, 32,611  
111,110, 32,127,111,110,101,702  
32,111,102, 32,116,104,101,590  
32,119,111,114,107, 32,116,631  
111,112,115, 46, 13,255, 16,668  
7, 83,117,110,100, 32,560  
97,115,100,101,101,112, 32,666  
97,116, 32,116,104,101, 32,598  
109,111,109,101,110,116, 33,689  
13,255, 16, 7, 32, 32, 32,387  
32, 32, 32, 32, 67, 79, 70,352  
11, 82, 65, 84, 85, 76, 65,528  
84, 73, 79, 70, 83, 33, 13,443  
255, 16, 7, 89,111,117, 32,627  
99, 97,110, 32,110,111,119,678  
32,114,101,116,117,114,110,704  
32,116,111, 32,116,104,101,612  
32, 76, 79, 85, 70, 71, 69,490  
127, 97,110,100, 32,101,110,677  
106,111,121, 32,116,104, 97,687  
116, 32,103,100, 97,115,115,694  
32,111,102, 32, 83, 72, 69,501  
82, 82, 89, 46, 13,255, 16,583  
7, 83,101, 97,114, 101,685  
32,119,104, 97,116, 63, 13,544  
255, 16, 5, 70,111,116,104,685  
105,110,103, 32,115,112,111,678  
99,105, 97,100, 32,116,111,668  
32,114,101,112,111,114,116,700  
46, 13,255, 16, 7, 84,104,525  
101, 32, 87, 73, 70, 68, 79,518  
87, 32,105,110, 32, 99,100,578  
111,115,101,100, 46, 13,255,741  
16, 7, 84,104,101, 32, 87,431  
73, 70, 68, 79, 87, 32,105,522  
115, 32,111,112,101,110, 46,627  
13,255, 16, 5, 89,111,117,686  
32, 99, 97,110, 39,116, 32,525  
114,101, 97, 99,104, 32,102,649  
104,101,119, 32,117,112, 32,627  
104,101,114,101, 33, 13,255,721  
16, 7, 84,104,101, 32, 67,411  
72, 73, 83, 69, 76, 32,109,314  
97,107,101,115, 32,110,111,673  
32,105,109,112,114,101,115,688  
115,105,111,110, 33, 13,255,742  
16, 7, 78,105, 99,101, 32,438  
67, 72, 82, 73, 83, 77, 65,519  
83, 32,100,101,115,105,103,639  
110, 46, 13,255, 16, 7, 82,529  
101,100, 32, 97,110,100, 32,572  
103,114,101,101,110, 32,115,676  
116,114,105,112,101,100, 32,680  
102,111,114, 32,116,105,101,681  
105,110,103,127, 67, 72, 82,666  
112,114,101,115,101,110,116,769  
115, 46, 13,255, 16, 7, 84,536  
104, 97,116, 39,115, 32,116,619  
111,111, 32,103,101,110,116,669  
114, 97,100, 32, 13,255, 16,636  
7, 89,111,117, 32, 97,114,567  
101, 32,110,111,116, 32, 67,569  
65, 82, 80, 89, 73, 78, 71,548  
32, 97,110,121,116,104,105,685  
110,103, 33, 13,255, 16, 7,537  
79,110,101, 32, 97,116, 32,567  
97, 32,116,105,109,101, 32,592  
111,110,100,121, 32,112,100,782  
101, 97,115,101, 33, 13,255,715  
16, 7, 79, 75, 46, 46, 46,315  
46, 97,100,100, 32,100,114,680  
111,112,112,101,100, 33, 13,582  
255, 16, 7, 84,104,101,114,681  
101, 39,115, 32,110,111, 32,540  
109,111,114,101, 32,114,111,692  
111,109, 32, 72, 69, 82, 69,544  
33, 13,255, 16, 7, 83,117,524  
114,101,100,121, 32,110,111,697  
116, 32,105,110, 32, 72, 69,536  
82, 69, 33, 13,255, 16, 7,475  
76,111,111,107,115, 32,100,660  
105,107,101, 32,115,104, 97,661  
110,105,110,103, 32,102,111,681  
97,109, 33, 13,255, 16, 7, 530  
76,105,107,101, 32,102,105,628  
110,101, 32,115, 97,110,100,652  
112, 97,112,101,114, 33, 13,582  
255, 16, 7, 83,109,111,111,692  
116,104, 44, 32,110,101,114,629  
121, 32,115,109,111,111,116,715  
104, 33, 13,255, 16, 7, 89,517  
111,117, 32, 97,114,100,110, 32,684  
119,101, 97,114,105,110,103,749  
32, 97, 32, 87, 72, 73, 84,477  
69, 32, 66, 67, 63, 82, 68,451  
33, 13,255, 16, 7, 79, 75,478  
46,46,121,111,117, 32,114,587  
101,109,111,110,101, 32,116,688  
104,101, 32, 66, 76, 65, 78,522  
75, 69, 84, 83, 32, 97,110,550  
100, 32,127,100,101, 97,110,682  
101, 32,116,104,101,109, 32,595  
111,110, 32,116,104,101, 32,606  
102,100,111,111,114, 46, 46,638  
46, 46, 46, 84,104, 97,116,539  
127, 79, 84, 84, 79, 77, 65,595  
70, 32,119,105,100,100, 32,582  
110,111,116, 32, 90,101, 32,600  
115,111, 32,104,101, 97,110,678  
121, 32, 70, 79, 87, 13,255,665  
0, 0, 0, 0, 0, 0, 0, 0, 0  
0, 0, 0, 0, 0, 0, 0, 0, 0  
0, 0, 0, 0, 0, 0, 0, 0, 0  
0, 0, 0, 0, 0, 0, 0, 0, 0  
24,444,254, 21,192, 62, 4,781  
58,137, 92,229,213,197, 4,924  
15,200, 0, 14,193,209,220,861  
201, 0, 0, 0, 0, 0, 0, 0, 0  
5, 16, 0, 19, 1, 32, 32,105  
78,111,116,104,105,110,103,727  
32,111,102, 32,105,110,116,680  
101,114,101,115,116, 32, 6,605  
32, 0, 0, 0, 30, 7, 1, 6,05  
16, 0, 0, 1, 1, 1, 35, 78,178  
111,116,104,105,110,103, 32,681  
97,116, 32, 97,100,100, 32,598  
32, 32, 32, 32, 32, 32, 32,224  
0, 0, 0, 17,171,28, 24,668  
254, 0, 48, 40, 71, 33,229,667  
220, 14, 0,126,254,255, 32,989  
5, 12,112,104, 32, 1, 35,400  
24,245,200, 68,228,200, 30,1011  
253, 35,126,254,255, 40, 3,946  
215, 24,247,200, 22,233, 19,965  
24,211, 32,117,254,126,254,1075  
0, 32, 1,201, 62,255,201,752  
0, 0, 255, 17, 4, 16, 0,294  
19, 1, 32, 32, 63, 32, 90,279  
111,120,101,100, 32, 68, 79,611  
76, 76, 32, 32, 32, 32, 32,312



32, 32, 32, 32, 32,255, 17,432  
5, 16, 0, 19, 1, 32, 32,105  
65, 32, 49, 50, 56, 75, 32,359  
81, 80, 67, 67, 84, 82, 85,550  
77, 32, 32, 32, 32, 32, 32,269  
32,255, 17, 7, 16, 2, 19,348  
1, 32, 32, 65, 32,114,101,377  
100, 32, 60, 79, 70, 67, 72,508  
79, 32, 32, 32, 32, 32, 32,271  
32, 32, 32, 32,255, 17, 5,405  
16, 0, 19, 1, 32, 32, 65,165  
32,100, 97,114,103,101, 32,587  
79, 84, 84, 79, 77, 65, 70,546  
32, 32, 32, 32, 32, 32, 32,224  
255, 17, 6, 16, 0, 19, 1,314  
32, 32, 65, 32,100,101,19,407  
101,100, 32, 66, 79, 80, 32,586  
32, 32, 32, 32, 32, 32, 32,224  
0, 19, 1, 32, 32, 65, 32,101  
104, 97,110,100, 32, 84, 79,686  
82, 67, 72, 32, 32, 32, 32,349  
32, 32, 32, 32, 32, 32, 32,255,447  
17, 7, 16, 0, 19, 1, 32,92  
32, 65, 32,112, 97,105,114,557  
32,111,102, 32, 66, 79, 79,381  
84, 83, 32, 72, 32, 32, 32,327  
32, 32, 32, 32, 7, 16, 2, 32,261  
19, 1, 32, 32, 65, 76, 65,291  
70, 75, 69, 84, 83, 32,105,526  
110, 32, 79,116,116,111,109,673  
97,110, 32, 32, 32, 32, 17,575  
6, 16, 0, 19, 1, 32, 32,106  
65, 32,115,109, 97,100,108,634  
32, 75, 69, 89, 32, 32, 32,361  
32, 32, 32, 32, 32, 32, 32,224  
32,255, 17, 6, 16, 0, 19,345  
1, 32, 32, 65, 32, 90,100,560  
117,110,116, 32, 67, 72, 73,587  
83, 69, 76, 32, 32, 32, 32,356  
72, 32, 32, 32,255, 17, 7,407  
16, 0, 19, 1, 32, 32, 65,165  
32, 99, 97,110, 32,111,102,583  
32,115,104, 97,110,105,110,681  
102, 32, 70, 79, 65, 77, 32,458  
255, 17, 6, 16, 0, 19, 1,314  
32, 32, 65, 32,103,100, 97,469  
115,115, 32,111,102, 32, 83,590  
72, 69, 82, 80, 89, 32, 32,458  
32, 32, 32,255, 17, 7, 16,391  
0, 19, 1, 32, 32, 65,10,259  
32,101,109,112,116,121, 32,623  
84, 85, 77, 66, 76, 69, 82,539  
32, 32, 32, 32, 32, 32, 32,255,447  
17, 7, 16, 0, 19, 1, 32,92  
32, 65, 32,104, 97,110,100,540  
119,114,105,116,116,101,110,701  
32, 70, 79, 84, 69, 32, 32,406  
32, 32,255, 17, 6, 16, 0, 3,258  
19, 1, 32, 32, 65, 32,116,297  
111,114, 99,104, 32, 32, 32,65,591  
84, 84, 69, 84, 83, 32, 32,472  
32, 32, 32, 32, 32,255, 17,432  
6, 16, 0, 19, 1, 32, 32,106  
65, 32,112, 97,105,114, 32,557  
111,102, 32, 83, 67, 73, 83,551  
83, 79, 82, 83, 32, 32, 32,423  
32,255, 17, 2, 16, 7, 19,348  
1, 32, 32, 83,111,109,101,469  
32,119,114, 97,112,112,105,691  
110,103, 32, 80, 60, 80, 69,539  
82, 32, 32, 32,255, 17, 5,405  
16, 0, 19, 1, 32, 32, 65,165  
32, 90, 97,100,100, 32,111,586  
102, 32, 83, 84, 82, 73, 78,534  
71, 32, 32, 32, 32, 32, 32,263  
255, 17, 7, 16, 0, 19, 1,315  
32, 32, 65, 32, 90,100, 97,464  
99,107, 32, 60, 73, 65, 82,526  
89, 32, 32

118,115, 32, 97,110,100, 32,596  
99,111,106,111,117,114,115,775  
46, 13, 16, 7, 84,104,105,375  
115, 32, 78, 65, 82, 68, 69,587  
82, 47, 83, 84, 79, 82, 69,526  
32, 99,110,116, 97,105,678  
110,115, 32,109, 97,110,121,694  
32,105,116,101,109,115, 32,610  
102,111,114, 32, 99,117,108,683  
105,110, 97,114,121, 32,117,696  
115,101, 32,116,111,103,101,679  
116,104,101,114, 32,119,105,691  
116,104, 32, 97, 32,118, 97,596  
114,105,101,116,121, 32,111,700  
102, 32,111,100,100,115, 32,592  
97,110,100, 32,101,110,100,650  
115, 46, 13, 16, 7, 89,111,397  
117, 32, 97,114,101, 32,114,687  
97,116,104,101,114, 32,117,681  
110,102, 97,109,105,108,105,736  
97,114, 32,119,105,116,104,687  
32, 32,116,104,105,115, 32,536  
114,111,111,109, 32, 98,117,692  
116, 32,121,111,117, 32,100,629  
111, 32,114,101, 99,111,103,671  
110,105,115,101, 32, 32,105,680  
116, 32, 97,115, 32, 98,101,591  
105,110,103, 32, 97, 32, 75,554  
73, 84, 67, 72, 69, 78, 44,487  
32,119,105,116,104, 32, 32,540  
32, 32, 32, 97,109,112,100,522  
101, 32,115,116,111,114, 97,686  
103,101, 32,115,112, 97, 99,659  
101, 32,97,110,100, 32,100,572  
114, 97,119,101,114,115, 46,760  
83,116, 97,105,114,115, 32,662  
100,101, 97,100, 32,100,111,649  
119,110, 32,105,110,116,111,703  
32,100, 97,114,107,110,101,661  
115,115, 46, 13, 16, 7, 32,344  
32, 32, 32, 32, 32, 73, 84,317  
32, 73, 83, 32, 68, 65, 82,435  
75, 32, 73, 78, 32, 72, 69,431  
82, 69, 33, 32, 32, 32, 32,312  
32, 32, 32, 13, 16, 6, 84,215  
104,101, 32, 67, 69, 76, 76,525  
65, 82, 32, 99,111,110,116,615  
97,105,110,115, 32,116,104,679  
101, 32,117,115,117, 97,100,687  
32, 32, 32,110,101,103,100,518  
101, 99,116,101,100, 32, 97,646  
110,100, 32,117,110,119, 97,665  
110,116,101,100, 32,104,111,674  
117,115,101,104,111,100,100,756  
105,116,101,109,115, 46, 32,624  
65, 32,112,114,111,109,105,649  
110,101,110,116, 32,111, 96,678  
106,101, 99,116, 32,105,115,674  
32, 97, 32, 32,100, 97,114,512  
103,101, 32, 67, 72, 69, 83,527  
84, 46, 13, 16, 6, 65, 32,262  
102,101, 97,116,117,114,101,748  
32,111,102, 32,116,104,101,598  
32,100,111,117,110,103,101,685  
32,105,115, 32,116,104,105,689  
115, 32,114, 97,116,104,101,679  
114, 32,117,110,117,115,117,722  
97,100, 32, 65, 76, 67, 79,524  
86, 69, 46, 13, 16, 6, 89,325  
111,117, 32, 97,114,101, 32,608  
105,116, 32,116,104,101, 32,608  
97,116,116,114, 97, 99,116,795  
105,110,101,100,121, 32, 32,617  
32, 32, 32,102,117,114,110,539  
105,115,104,101,100, 32, 76,633  
79, 85, 78, 71, 69, 46, 32,468  
65,100,100, 32,105,115, 32,565  
113,117,105,101,116, 32, 32,616  
97,110,100, 32,112,101, 97,649  
99,101,102,117,100, 32, 97,656  
115, 32,116,104,101, 32, 99,599  
104,105,100,100,114,101,110,742  
32, 97,114,101, 97,116, 32,589  
100,111,110,103, 32,100, 97,669  
115,116, 32,115,111,117,110,716  
100, 32, 97,115,100,101,101,654  
112, 46, 32, 84,104,101, 32,511  
32, 68, 73, 78, 73, 78, 71,473  
45, 82, 79, 79, 77, 32,105,499  
115, 32,116,111, 32,116,104,626  
101, 32, 69, 65, 83, 84, 44,478  
32, 97,110, 32, 32, 65, 76,444  
77, 79, 86, 69, 32,105,115,553  
32, 78, 79, 82, 84, 72, 32,459  
97,110,100, 32,116,104,101,668  
32, 65, 73, 84, 82, 65, 78,408  
67, 65, 72, 65, 76, 76, 32,507  
105,115, 32, 83, 79, 85, 84,583  
72, 46, 13, 16, 7, 67,104,325  
97,111,115, 32,105,115, 32,687  
116,104,101, 32,111,114,100,678  
101,114, 32,111,102, 32,116,608  
104,101, 32,100, 97,121, 32,587  
105,110,116,104,105,115, 32,687  
68, 73, 78, 73, 78, 71, 45,486  
82, 79, 79, 77, 32, 97,116,562  
32,100,101, 97,100, 32,116,595  
100,109,101,115, 32, 84,579  
104,101, 32, 74, 79, 85, 78,555  
71, 69, 32,105,115, 32, 87,511  
69, 83, 84, 32,119,104,105,576  
100,101, 32,102,114,101,110,666  
99,104, 32,119,105,110,100,669  
111,119,115, 32,100,101, 97,683  
100, 32,116,111, 32,116,104,611  
101, 32, 86, 65, 84, 73, 79,514  
46, 13, 16, 7, 89,111,117,397  
32, 97,100,109,111,115,116,688  
32, 98,114,111,107,101, 32,593  
121,111,117,114, 32, 98, 97,690  
99,107, 32, 98,121, 32, 32,921  
32,100, 97,121,105,110,103,676  
32,116,104,105,115, 32, 88,584  
65, 84, 73, 79, 44, 32, 98,475  
117,116, 32,121,111,117, 32,646  
119,101,114,101, 32,114, 97,678  
116,104,101,114, 32,112,100,607  
101, 97,115,101,100, 32,119,665  
105,116,104, 32,116,104,101,678  
32,102,105,110, 97,100, 32,519  
32, 32,111,117,116, 99,111,616  
109,101, 46, 32, 65, 32,115,580  
104,101,100, 32,105,115, 32,589  
116,111, 32,116,104,101, 32,612  
69, 65, 83, 84, 44, 32, 97,474  
32, 71, 65, 82, 65, 71, 69,455  
32,105,115, 32, 65, 79, 85,531  
84, 72, 32, 97,110,100, 32,327  
116,104,101, 32, 87, 73, 78,591  
68, 79, 97,100,101, 97,100,640  
105,110,103, 32,105,110,116,601  
111, 32,116,104,101, 32,104,680  
111,117,115,101, 32,105,115,614  
32, 87, 69, 83, 84, 46, 13,414  
16, 6, 89,111,117,114, 32,703  
111,119,110, 32,112,114,105,705  
110, 97,116,101, 32,101,115,680  
99, 97,112,101, 32,104,111,656  
109,101, 46, 32, 32, 32, 78,429  
111, 45,111,110,101, 32,101,611  
100,115,101, 32,105,115, 32,608



97,100,100,111,119,101,100,744  
32,105,110, 32,116,104,105,684  
115, 32, 32, 83, 72, 69, 60,471  
33, 32, 65,100,111,110,103,562  
32,111,110,101, 32,119,97,682  
100,100, 32,105,115, 32, 97,597  
32,119,114,110,100, 32, 97,532  
114,107, 32, 66, 69, 78, 67,533  
72, 46, 13, 16, 5, 84,104,348  
101, 32, 71, 65, 82, 65, 71,487  
69, 32,105,115, 32, 98, 97,548  
114,101, 32, 97,115, 32,121,612  
111,117,114, 32,111,116,104,705  
101,114,104, 97,110,102, 32,658  
104, 97,115, 32,116,104,101,669  
32, 99, 97,114, 46, 32, 79,499  
110, 32,111,110,101, 32,119,615  
97,100,100, 32,105,115, 97,662  
110, 32,111,100,100, 32, 67,560  
85, 80, 66, 79, 65, 82, 68,525  
32,117,115,101,100, 32, 97,594  
115, 32, 97, 32,104, 97,110,587  
100,121, 32,115,116,111,114,709  
101, 46, 32, 87, 69, 85, 84,582  
32,100,101, 97,100,115, 32,585  
116,111, 32,116,104,101, 32,612  
83, 84, 85, 68, 89, 32, 32,473  
97,110,100, 32,116,104,101,668  
32, 88, 65, 84, 73, 79, 32,445  
105,115, 32,116,111, 32,116,627  
104,101, 32, 78, 79, 82, 84,568  
72, 46, 13, 16, 6, 88, 73,588  
69, 32, 82, 84, 85, 68, 89,518  
44, 32,119,105,116,104, 32,552  
97, 32,118,101,114,121, 32,615  
100, 97,114,103,101, 32, 97,652  
110,100,105,109,112,114,101,751  
115,115,105,118,101, 32, 68,654  
69, 83, 75, 32, 97,115, 32,583  
105,116,115, 32,109,111,115,703  
116, 32, 32, 32, 32, 32,112,380  
114,111,109,105,110,101,100,700  
116, 32,102,101, 97,116,117,681  
114,101, 46, 32, 69,120,105,587  
116,115, 32, 97,114,101, 32,687  
32, 32, 32, 78, 79, 82, 84,419  
72, 44, 32, 69, 65, 83, 84,449  
32, 97,110,100, 32, 87, 69,527  
83, 84, 46, 13, 16, 6, 84,332  
104,105,115, 32,105,115, 32,609  
116,104,101, 32, 69, 78, 84,584  
82, 65, 78, 67, 69, 32, 74,665  
65, 76, 76, 32,111,102,102,564  
32, 32, 32,119,104,105, 99,523  
104, 32,105,115, 32,116,104,680  
101, 32, 83, 64, 85, 68, 89,542  
32,116,111, 32,116,104,101,612  
32, 69, 65, 83, 84, 44, 32,489  
116,104,101, 32, 74, 79, 85,593  
78, 71, 69, 32,116,111, 32,589  
116,104,101, 32, 78, 79, 82,592  
84, 72, 32, 97,110,100, 32,527  
97, 32, 32, 32, 98,117, 98,587  
98,121, 32,104,111,100,101,675  
32,117,110,100,101,114, 32,686  
116,104,101, 32,116,111, 97,681  
105,114,115, 32,116,111, 32,625  
32,116,104,101, 32, 87, 69,531  
83, 84, 46, 13, 16, 7, 84,335  
104,105,115, 32, 99,117, 98,670  
98,121, 32,104,111,100,101,678  
32,117,110,100,101,114, 32,686  
116,104,101, 32,115,116, 97,681  
105,114,115,105,115, 32, 97,683  
32,102, 97,110,111,117,114,691  
105,116,101, 32,104,105,100,663  
105,110,103, 32,112,100, 97,667  
99,101, 32,102,111,114, 32,591  
121,111,117,114, 32, 99,104,698  
105,100,100,114,101,110, 44,682  
32, 97,110,100, 32,121,111,683  
117, 32,104, 97,110,101, 32,601  
116,111, 32, 99,114,111,615  
117, 99,104, 32,100,111,119,685  
110, 32,116,111, 32,103,101,685  
116, 32,105,110, 32,116,111,622  
32,105,116, 46, 13, 16, 7,335  
89,111,117,114, 32,104,117,684  
115, 98, 97,110,100, 32,119,671  
111,114,107,101,100, 32,118,683  
101,114,121, 32,104, 97,116,685  
100, 32,105,110,100, 97,121,675  
105,110,103, 32,116,104,105,675  
115, 32, 80, 65, 84, 73, 79,528  
32, 97,110,100, 32,104,101,576  
32,105,115, 32,110,101,114,617  
121,112,114,111,117,100, 32,787  
111,102, 32,104,105,115, 32,681  
104, 97,110,100,105,119,117,646  
114,107, 33, 32, 65, 32,183,486  
97,114,100,101,118, 83, 72,677  
69, 68, 32,105,115, 32,116,537  
111, 32,116,104,101, 32,101,597  
97,115,116, 44, 32, 83, 79,566  
85, 84, 72, 32,100,101, 97,579  
100,115,116,111, 32,116,104,694  
101, 32, 71, 65, 82, 65, 71,487  
69, 32, 97,110,100, 32,116,566  
104,101, 32, 87, 73, 78, 68,543  
79, 87, 32, 32, 32, 32,100,482  
101, 97,100,105,110,103, 32,648  
105,110,116,111, 32,116,104,694  
101, 32,104,111,117,115,101,681  
32,105,115, 32, 87, 69, 83,523  
84, 46, 13, 16, 6, 89,111,565  
117, 32, 97,114,101, 32,110,683  
111,116, 32,110,111,114,109,703  
97,100,100,121, 32, 97,100,671  
100,111,119,101,100, 32,105,676  
110, 32,116,111, 32,116,104,621  
105,115, 32, 63, 72, 69, 68,544  
32, 97,115, 32,105,116, 32,529  
105,115, 32, 99,111,110,115,687  
100,100,101,114,101,100,116,737  
111, 32, 98,101, 32,121,111,686  
117,114, 32,104,117,115, 98,697  
97,110,100, 39,115, 32,100,595  
111,100, 97,105,110, 46, 32,610  
32, 32, 32, 65,100,111,110,498  
105, 32,111,110,101, 32,119,488  
97,100,100, 32,105,115, 32,597  
97,110, 32,111,100,100, 32,598  
66, 69, 78, 67, 72, 46, 13,411  
16, 7, 84,104,105,115, 32,463  
109,111,100,101,114,110, 32,677  
75, 73, 84, 67, 72, 69, 78,510  
32,105,115, 32, 97,100,100,597  
32, 32, 32, 32, 32, 32,115,387  
112, 97,114,107,100,105,110,753  
103, 32,119,104,105,116,101,680  
32, 97,110,100, 32,103,100,582  
101, 97,109,105,110,103, 46,671  
32, 32, 32, 73,116, 32,105,422  
115, 32,119,101,100,100, 32,615  
102,105,116,110,101,100, 32,672  
111,117,116, 32,119,105,116,716  
104, 32, 97,109,112,100,101,663  
115,116,111,114, 97,103,101,757  
32,115,112, 97, 99,101, 32,588  
97,110,100, 32,100,114, 97,650



119,101,114,115, 46, 32, 68,595  
79, 87, 78, 32,102,114,111,685  
100, 32,104,101,114,101, 32,593  
100,101, 97,100,115, 32,116,669  
111, 32,100, 97,114,107,110,671  
101,115,115, 46, 13, 8, 8,390  
0,232,190,232,114, 0, 8,776  
209,106,233, 69, 0, 0, 8,697  
0, 0, 0, 0, 0, 0, 0, 0  
1, 0, 0, 0, 0, 0, 0, 4,5  
2, 0, 0, 0, 0, 0, 0, 4,6  
3, 0, 0, 4, 0, 0, 0, 0,7  
4, 5, 0, 7, 3, 1, 20,48  
5, 0, 4, 0, 0, 0, 0, 8,9  
6, 0, 7, 0, 0, 0, 0, 8,13  
7, 6, 0, 0, 4, 0, 0, 0,25  
8, 0, 0, 0, 7, 0, 0, 0,15  
9, 0,10, 0, 0, 0, 0, 0, 0,19  
10, 9, 15, 0, 0, 0, 0, 12,46  
11, 0, 0, 0, 0, 0, 10, 0,21  
12, 0, 0, 0, 0, 0, 10, 0,22  
13, 0, 14, 0, 0, 0, 0, 0,27  
14, 13, 20, 15, 0, 0, 0, 0,62  
15, 10, 19, 16, 14, 0, 0, 0,74  
16, 0, 18, 17, 15, 0, 0, 0,66  
17, 0, 0, 0, 16, 0, 0, 0,33  
18, 16, 0, 18, 20, 0, 0, 0,55  
19, 15, 0, 18, 20, 0, 0, 0,72  
20, 14, 0, 19, 21, 4, 0, 0,78  
21, 0, 0, 20, 0, 0, 0, 0,41  
0, 0, 0, 3, 0, 13, 16,32  
0, 0, 0, 14, 0, 8,38  
0, 0, 0, 0, 68, 79,147  
76, 76, 0, 1, 83, 80,69,385  
67, 84, 2, 88, 79, 78, 67,457  
72, 3, 79, 84, 84, 79, 77,478  
4, 66, 79, 88, 0, 0, 5,242  
84, 79, 82, 67, 72, 6, 66,456  
79, 79, 84, 83, 7, 66, 76,474  
65, 78, 75, 8, 75, 69, 89,459  
0, 0, 9, 67, 72, 73, 83,384  
69, 10, 70, 74, 69, 77, 8,378  
11, 85, 72, 69, 82, 82, 12,411  
84, 85, 77, 66, 76, 13, 78,479  
94, 84, 69, 0, 14, 66, 65,377  
94, 84, 69, 15, 85, 67, 73,475  
83, 83, 16, 80, 65, 80, 69,476  
82, 17, 83, 84, 82, 73, 78,499  
18, 68, 73, 65, 82, 89, 19,414  
84, 79, 87, 69, 76, 28, 66,481  
76, 65, 78, 75, 21, 68, 79,462  
76, 76, 0, 1, 83, 80, 69,385  
67, 84, 2, 88, 79, 78, 67,457  
72, 3, 79, 84, 84, 79, 77,478  
4, 66, 79, 88, 0, 0, 5,242  
84, 79, 82, 67, 72, 6, 66,456  
79, 79, 84, 83, 7, 78, 79,489  
82, 84, 72, 29, 83, 79, 85,414  
84, 72, 30, 69, 65, 83, 84,487  
31, 87, 69, 83, 84, 0, 254  
32, 85, 80, 0, 0, 33,208  
68, 79, 87, 78, 0, 34, 78,424  
0, 0, 0, 0, 29, 83, 8,112  
0, 0, 0, 30, 69, 0, 8,99  
0, 0, 31, 87, 0, 0, 8,118  
0, 32, 85, 0, 0, 0, 8,117  
33, 68, 0, 0, 0, 0, 34,130  
76, 79, 79, 75, 0, 0, 36,484  
0, 0, 0, 8, 9, 82, 8,181  
0, 0, 0, 9, 76, 73, 83,331  
84, 8, 99, 73, 8, 0, 8,256  
0, 99, 73, 78, 64, 69, 78,483  
99, 81, 85, 73, 84, 0, 99,521  
83, 84, 79, 88, 0, 99, 83,588  
65, 86, 69, 0, 99, 76, 79,474  
65, 68, 0, 99, 84, 82, 85,483  
78, 73, 54, 65, 84, 84, 73,513  
67, 29, 76, 65, 78, 68, 73,466  
38, 66, 69, 68, 0, 0, 31,264  
82, 69, 79, 77, 0, 32, 84,433  
65, 66, 76, 69, 33, 87, 65,461  
82, 68, 82, 34, 83, 84,

# THE ARCHERS

People get pretty serious about *The Archers*. If you've found your hackles rising at the way Pat has been misrepresented and misunderstood in that patriarchal hotbed of chauvinism, Ambridge, or if your blood boils at the ruthless way Brian led Caroline astray in the cool setting of the Mont Blanc restaurant, don't give up hope – here is a chance to put the record straight on their behalf.

Welcome to **The Archers** – the computer game.

The idea is that you assume the role of a trainee scripwriter on the radio series, and make plot decisions for four of the main characters – Jack Woolley,

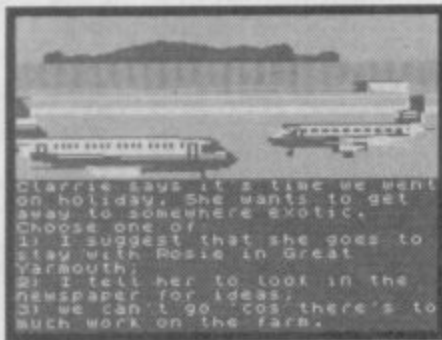

Elizabeth Archer, Eddie Grundy and Nelson Gabriel.

It's been programmed by Level 9 and the gameplay works a little line that in its earlier *Adrian Mole* game. Where *Mole* fell down was with the tedious cycling through of multiple-choice question and answers.

**The Archers** works basically the same way, but the multiple questions are properly integrated into the plot and the whole thing – unlike *Mole* – really does hang together.

Your success or failure at the game is reflected by the audience ratings which appear on the screen from time to time, together with winging memos from the Controller of Radio 4 – a hard man to please.

Understandable perhaps, since it's he who gets the flack when the delicate sensibilities of **The Archers** listenership are in any way offended. These people mean business. An example: irate civil rights groups inundated the BBC with threatening letters when I unwittingly got Shane fired. When I chose plotline option 'Save on wages' (part of Nelson's economy drive) it was without realising that his most important and – apart from the window cleaner whom you can opt to have drenched with water by Elizabeth Archer – seemingly his only employee, would have to go. Bad move. Shane is Glad To Be Gay and as Bortchester tends not to lead on socio-sexual issues, the last thing CR4 wants is its sole representative of an oppressed



minority written out.

The 'writing out' of a character is a subtle business and all too easy for the uninitiated to do unwittingly. I thought a nice long holiday in Guernsey would do Jack Woolley the world of good. Up came CR4's angry memo complaining that, as any listener knows, nobody goes on holiday to Guernsey unless they're being written out.

It may seem as though you set out playing God in Ambridge but, as the blurb says, the plot has its own momentum, and events can

death by whisking him off to hospital, at which point an audience rating came up, followed by my telling Clarrie to look in the newspaper for ideas (a reference to a totally different sub-plot involving holidays) and then a quick switch back to the bank manager.

These mysterious interruptions – by bits of stray text, bugs perhaps? – and the odd textual error detracted a little from an otherwise highly entertaining and very witty game.

My biggest criticism would be the way the text would

## ADVENTURE



## REVIEW

sometimes disappear off screen before there had been time to read it. Once or twice, ten lines or so of text would just vanish – hurtling off the screen at some absolutely crucial dramatic moment.

The game was great fun though, despite the irritating bugs in the program, and I found myself laughing out loud on a number of occasions – for how many games can that be said? Just how entertaining it would be for non-*Archers* fans is harder to say.

It may not be demanding enough to hold the attention of a hardened adventurer indefinitely, but it's a must for anyone who only comes to life between 10.15 and 11.15 on a Sunday morning. ■

### FACTS BOX

*Great in-joke for Archers fans but managed to be funny on its own merits too. Marred a little by some curious mistakes*

★	THE ARCHERS
★	Label: Mosaic
★	Author: Level 9
★	Price: £9.95
★	Memory: 48K/128K
★	Reviewer: Lolita Taylor

easily get out of hand. At one point I felt as though the plot was going round and round in circles and, no matter what option I chose, I kept coming back to the same decision point – as Eddie Grundy, my pay rise depended on how well things went with the turkeys. To get more money, either I had to a) tout for business around the village, b) raid Martha's post office or c) raid Joe Grundy's sock drawer. There were moments when it seemed as though I had in fact a very small part in the action and I was just pressing anything to get out of this cycle.

On other occasions the storyline wasn't coherent. Again as Eddie Grundy, I saved the Bank Manager from certain

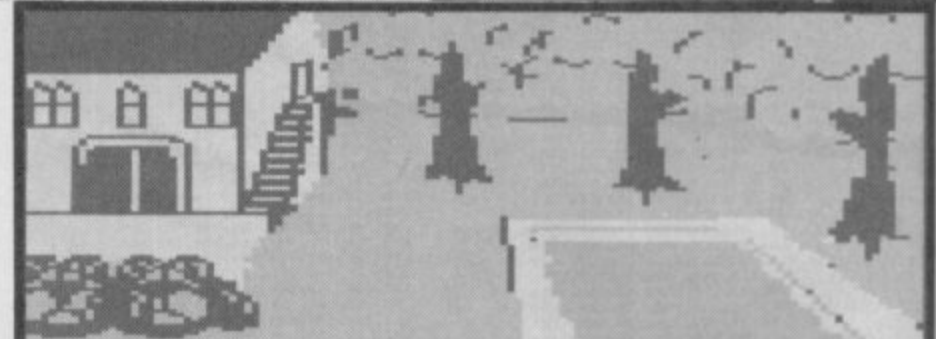

Select one of:

- 1) call the police;
- 2) pretend it's a party;
- 3) haul them out.

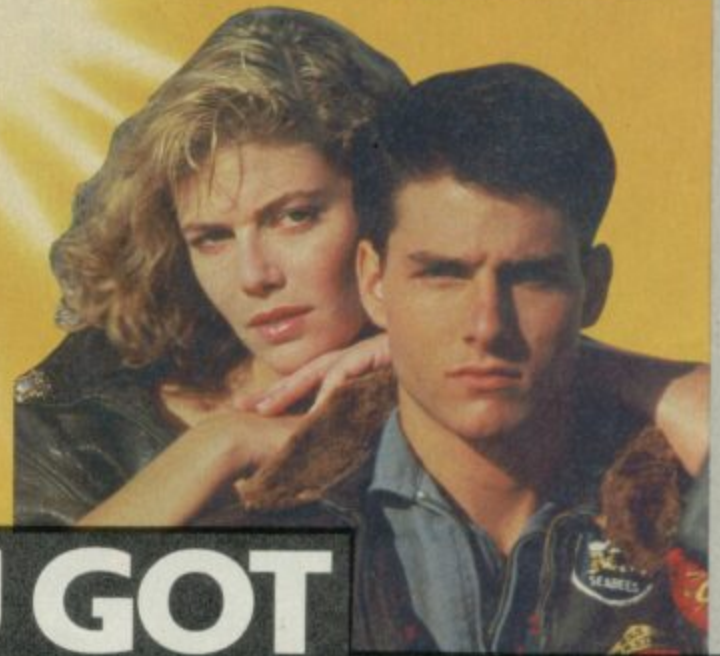

**HAVE YOU GOT  
WHAT IT TAKES TO BE A**

# **TOP GUN**

TM

Top Gun puts you in the fighter pilot's seat of an F-14 Tomcat. Vector graphics and a split screen allow 1 or 2 players to play head to head, or against the computer.

Your armaments in this nerve tingling aerial duel are heat seeking missiles and a 20mm rapid fire cannon. Can you feel the force! Top Gun mavericks! Enter the danger zone.

**£7.95**  
SPECTRUM



**£8.95**  
AMSTRAD/COMMODORE

Ocean Software Ltd., 6 Central Street, Manchester M2 5NS. Telephone: 061-832 6633. Telex: 669977 OCEAN G.

Ocean Software. Distributed in France by Ocean France. Telephone: 93-42-7144. Distributed in Germany by Rushware. Telephone: 2101-70040.

TM & © 1986 Paramount Pictures Corporation. All Rights Reserved. TM is a trademark of Paramount Pictures Corporation.

AMSTRAD 18-95

ZX SPECTRUM 17-95

# Konami's GOLF™

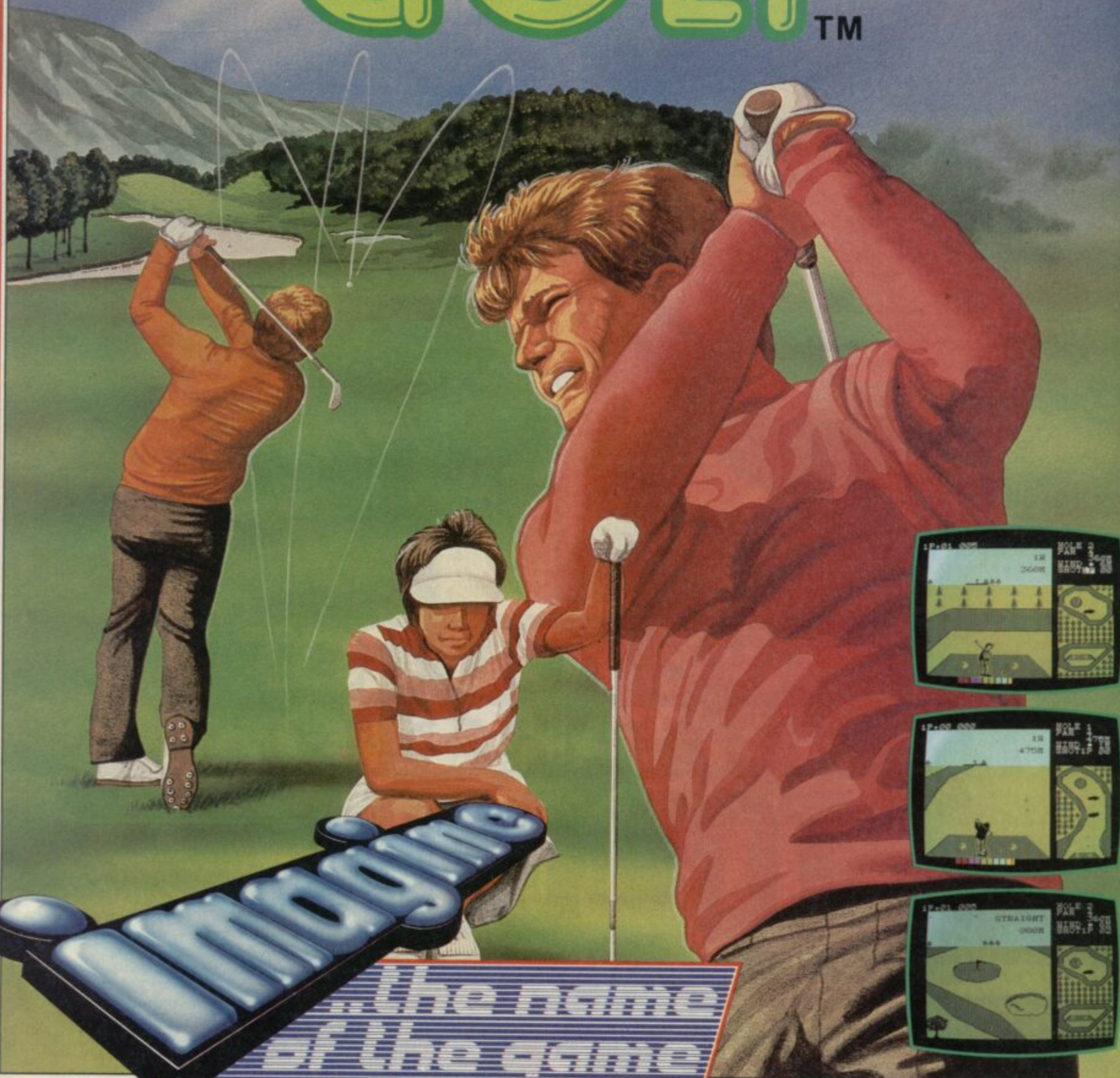

...the name  
of the game

Select your club and prepare to tee-off with this superb golf-simulation from Konami reproducing all the features from the live game – choose stroke or match play with differing terrain and conditions. So if the weather turns bad don't worry it'll just improve your play for the sunny days!



The latest Piranha offering is based on a film starring Klaus Kinski, making it the only piece of software ever to have been licenced from a European art movie.

I bet Piranha didn't have to pay much for the deal.

The film was called *Nosferatu*, as is the game. If that's unfamiliar perhaps you will recognise it by another name – *Dracula*. Head honcho in the vampire department.

The game's been created for Piranha by Design Design who have been popping up a lot recently – mainly for Piranha.

Objectively, it's a big game. Three sections loaded in a

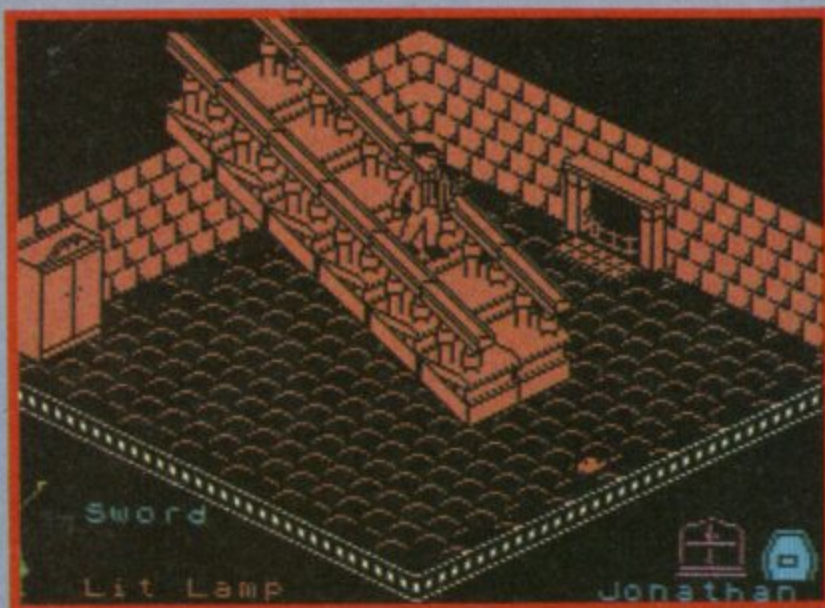

# NOSFERATU

couple of blocks each a full game in itself. Although the three sections are integrated quite closely it isn't possible to move from section to section without completing at least some parts of the task in the previous section.

A *Dracula* game could have been done so many ways: a run around dodging things game or an adventure. Perhaps the least expected approach is that it should be turned into a Knight Lore/Batmanish 3D edge-on-big-sprite-epic – but that's just what this is. In the three sections you control one or more characters including, gasp, Lucy (a woman) – each a fully animated figure who can walk around, go down stairs and, well, actually that's about it really. Other activities like getting objects and using the occasional sword seem to happen invisibly. There isn't even a 'jump' option – there are places where you have to climb (notably some ladders in the library) and where you have to descend (various staircases) but it just happens automatically.

It struck me part way through the game that there was almost no reaction element to it at all – it's an arcade adventure where

solving the puzzles dominates the play. True, you get attacked by bats on a regular basis but there isn't a lot you can do about it in terms of joystick technique, no matter how you waggle the stick you won't avoid 'em. (This is not to say there is nothing you can do, there definitely is, but it doesn't require hot reactions). There are a couple of areas where you have to time your way past a couple of roving wolves (although actually they look like the pet pooch) but it really isn't very difficult. I'm not sure whether this is a criticism exactly but certainly it's important to realise it is a game of puzzles.

The puzzles take various forms. Eating food you might find is wise and obvious. Finding boots to stomp on the spiders seems less so. Sometimes there are objects in cupboards and consequently whenever you find such a container it's worth walking up to it and pressing the 'pick up' key. Sometimes energy may be restored, sometimes you may find a gun, you may even find the deeds to the castle, and getting out with them is the point of Part 1 of the game.

There's quite a lot going on in

## FACTS BOX

*Visually excellent. It's inventive and ambitious. Definitely designed for puzzlers rather than battlers though*



NOSFERATU

Label: Piranha



Author:

Design Design

Price: £9.95



Memory:

48K/128K



Joysticks:

various



Reviewer:



Galen Taylor

Part 1 – a few secret rooms and secret passages (here's a clue – where would you expect to find the entrance to a secret passage?) and objects with mysterious uses.

The game looks superb, particularly the detailed backgrounds which are more than just good to look at – they are actually atmospheric. Check out the rats scurrying around

◀ A room in Part 1 ● On the drawer a lamp ● At the moment, you will discover it is useless ● In the bathroom some spiders ● Now, what can you find to squidge them with ● Anything in the cupboard? ▼

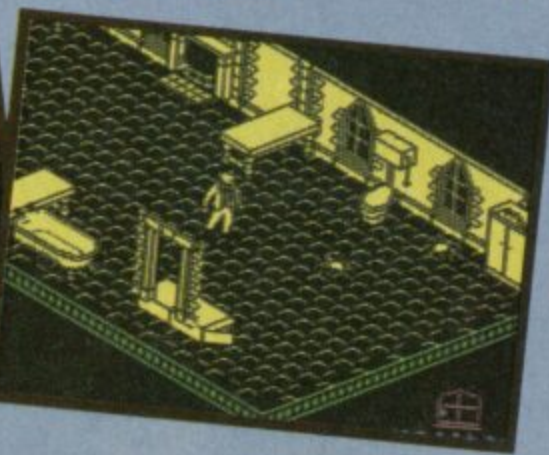
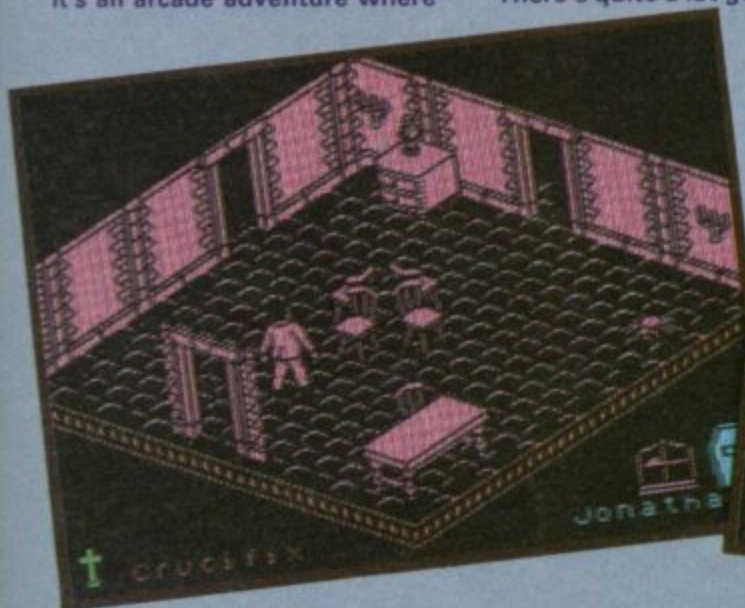

the cellar, look out too for the furniture stacked up ominously.

In Part 2 – you play three characters and your task is more complex. The village outside the castle is being turned into vampireville as Dracula turns more and more people into mindless blood-sucking zombies (just like members' of fundamentalist religions really). You have to kill them with a stake through the heart and use Lucy as bait to lure Dracula into her room where, maybe, he can be killed.

Although the town is just as beautifully realised at the castle (the rooms interiors in particular) the townspeople are all constructed from the same two sprites (because of memory limitations apparently), one male and one female. It looks fairly bizarre and means you only know which one is you by actually seeing which character moves under your control. Another strange touch is that the female character totally lacks legs and moves around as though being wheeled around on rollers (an old programmers trick to avoid having to animate legs).

Getting the stakes is neat. First you find an axe, then you look for any wood that might be lying around – like a chair for example.

In Part 3, more of an endgame really, you must, having lured Dracula to Lucy's room, keep him there. This involves some tricky action with stakes, garlic and the rest. If he doesn't manage to get away before dawn you've done it, because, as we all know, at dawn vampires dissolve into special effects unless safely tucked up in their graves.

My doubts stem from the fact that despite being so strong visually it lacks 'action'. There are no occasions really when your joystick will even get warm. These doubts make *Nosferatu* a few points less than a *Classic*.

# A Forest of Fascinating Fantasy

Enter the darkness and embark on a path of mystery and intrigue – terror and panic – stealth and cunning. A series of adventures and brain twisting journeys with a challenge and scenario to test the most formidable adventurer.

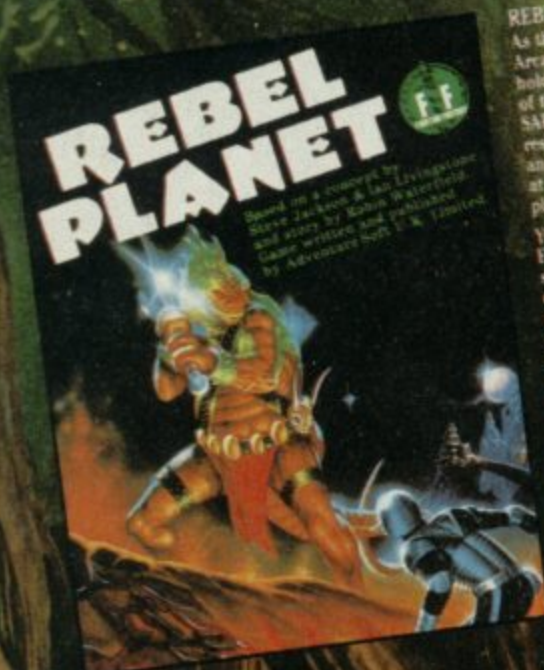

## REBEL PLANET

As the might of the alien Arcadian Empire tightens its hold on our galaxy, the leaders of the secret Earth organisation, SAROS, gather their slender resources into one last daring and foolhardy mission to strike at the heart of the invaders home planet.

YOU are their last hope. Equipped with a forbidden laser sword, your mission is to seek out the underground resistance and piece together the vital code you need to destroy the enemy. But time is running out and only YOU stand in the way of the Arcadians' complete domination of the galaxy.

CBM 64/128 £9.95 \$14.95 Disk  
Spectrum £9.95 Spectrum Plus \$9.99  
Amstrad £9.95 \$14.95 Disk  
BBC/Electron £7.95

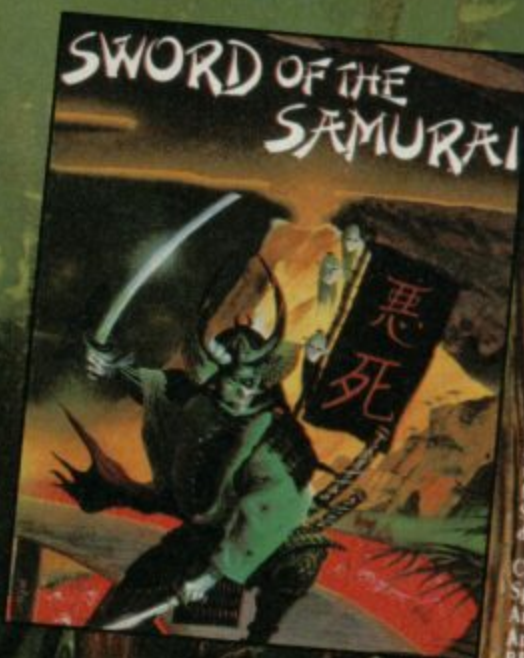

## SWORD OF THE SAMURAI

### SWORD OF THE SAMURAI

The land of Hachiman is in grave danger. The Shogun's control is slipping. Bandits roam the land freely and barbarian invaders have begun to raid across the borders. All this because the Dai-Katana, the great sword, Singing Death, has been stolen from the Shogun.

YOU are the Shogun's champion, a young Samurai. Your mission is to recover this wondrous sword from Ikiru, the Master of Shadows, who holds it hidden deep in the Pit of Demons.

CBM 64/128 £9.99 \$14.99 Disk  
Spectrum £8.99  
Amstrad/Spectrum Plus £9.99  
Amstrad Disk \$14.99  
BBC/Electron £7.99 Text only

## Isaac Asimov's KAYLETH



**KAYLETH**  
The Zyroneans were an advanced, pacifistic civilisation, until the arrival of Kayleth and his obsessional craving for Chronazin.

Now, Kayleth rules the Zyronean skies with awesome power, using an Atomic Dissembler system to send down his powerful army of androids to enslave the Zyroneans.

You, a loyal Zyronean, have avoided capture long enough to set into motion a plan to liberate your beloved planet. However, as you are about to discover, certain events have overtaken your well laid schemes!!

CBM 64/128 £9.99  
Amstrad £9.99  
Spectrum 128K £9.99  
Spectrum 48K \$8.99  
BBC/Electron £9.95  
IBM (Disk) \$19.99

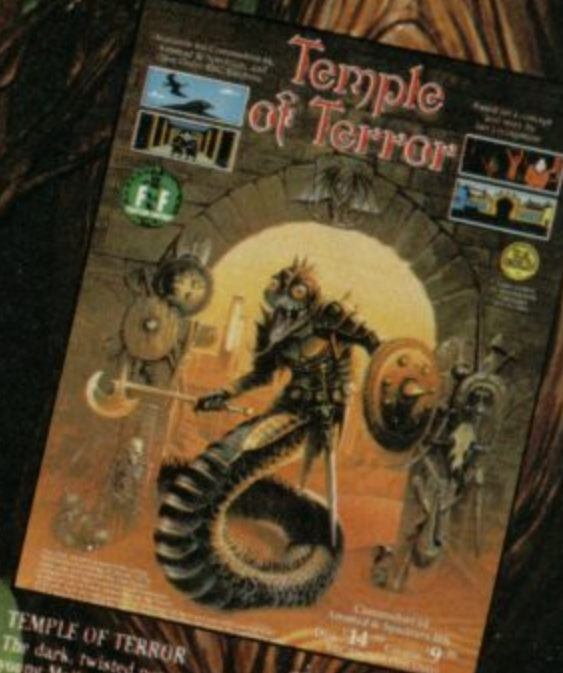

## Temple of Terror

### TEMPLE OF TERROR

The dark, twisted power of the young Malbordus is reaching its zenith. All he needs now is to retrieve the five dragon artefacts which have been hidden for centuries in the lost city of Valos somewhere in the Desert of Skulls. Each day that passes brings him closer to them and only YOU can stop him! YOUR mission is to reach the lost city before Malbordus and destroy the treasures he seeks. But beware! Each step you take leads you closer to your doom.

CBM 64/128 £9.99  
\$14.99 Disk  
Spectrum £8.99  
Amstrad/Spectrum Plus £9.99  
Amstrad Disk \$14.99  
BBC/Electron £7.99 Text only





**CONTROL ROOM**  
I can hear the steady beeping of the sonar device.  
(S, E, W, U)

Running an adventure helpline is a bit like sitting in the tap-room of some bizarre nineteenth century travellers' pub. Stay there long enough and you'll pick up snippets of information about hundreds of outlandish places and events. Sometimes you can rely on the gossip, sometimes you can't but you store it all away hoping it may come in useful for other travellers.

You end up with a map of a fantasy world that's always incomplete and usually resembles those medieval charts of faraway places which get rather vague in

the middle – often decorated with pictures of men with heads in the centres of their body or statements like 'here be dragons'.

So now and again it's nice to get hold of a traveller who's taken great care to document his journeys fully. Sandy Duncan of Glasgow has sent in no less than eighteen full solutions and maps. Here's the first for the Firebird effort

### Subsunk,

◆ a game that still troubles many of you. Anyway, let's hear it for Sandy, a true philanthropist – look it up,

# GORDO'S HELPLINE

## SUB-SUNK by Firebird.

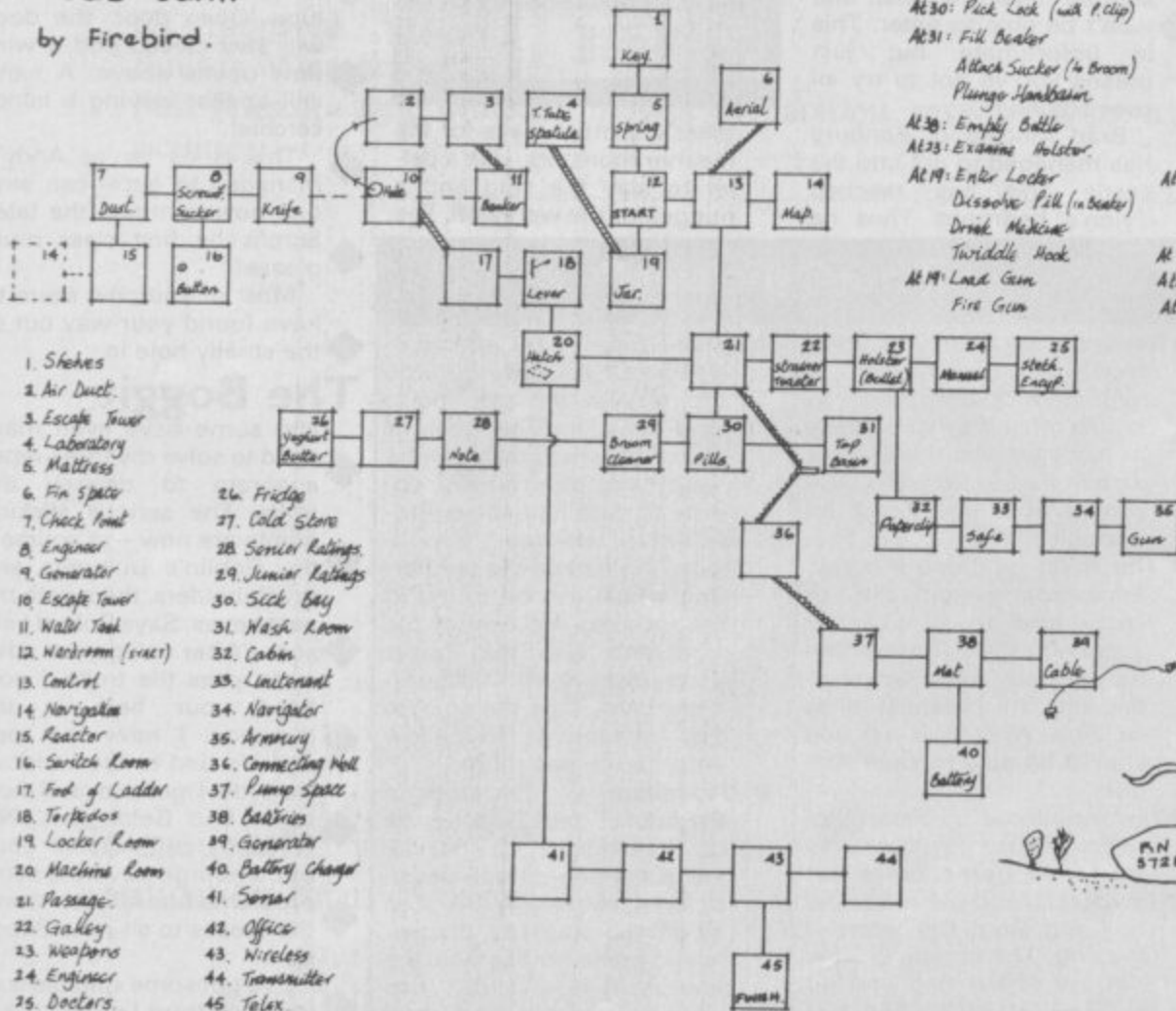

- At 5: Wear Strainer, Jump
- At 19: Open Locker (with Key)
- At 32: Examine Desk... take P. Clip
- At 30: Pick Lock (with P. Clip)
- At 31: Fill Beaker  
Attach Sucker (to Broom)  
Plungo Handbroom
- At 38: Empty Bottle
- At 23: Examine Hulster
- At 19: Enter Locker  
Dissolve Pill (in Beaker)  
Drink Medicine  
Twiddle Hook
- At 19: Load Gun  
Fire Gun
- At 7: (with Cleaner)  
Insert Battery  
Press Switch  
Clear Dust  
Press Switch  
Dismantle Cleaner (Screw)  
Take Cloth  
Examine Cloth  
Take Battery
- At 20: (with Battery)  
Spill Acid  
Open Hatch  
At 22: Scrape Toast  
At 27: Wear After Shave  
At 23: Butter, Yogurt, Map  
Cloth, Scrapings
- Splice, and Test Tube  
Pour Yogurt  
Mix Test Tube  
Glue Map  
At 23: Wear Stethoscope  
Turn L, L, A.  
At 18: Spread Butter  
On Tube  
Connect Cable  
At 44: Insert Bedspring  
Connect Cable  
At 18: Insert Aerial  
Pull Lever  
At 45: Insert Tape  
—  
Message: 'Sub Sunk'

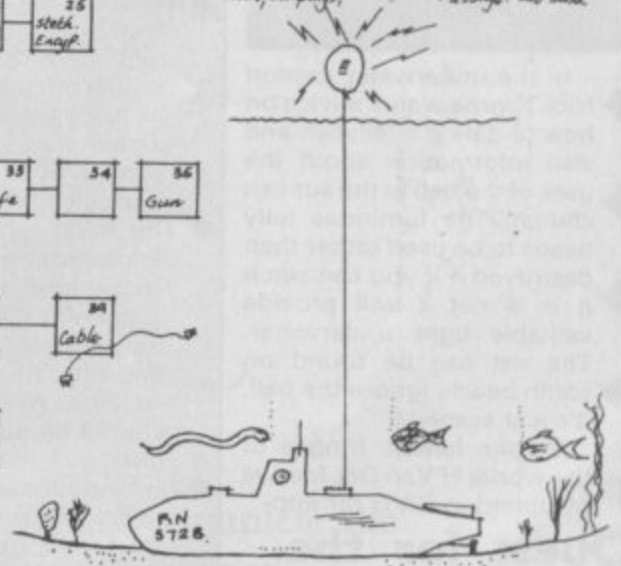



# GORDO'S HELPLINE

it's nothing to do with booze. Now to business with a number of queries on

## Adventure Quest,

now part of Level 9's **Jewels of Darkness** trilogy. Alex Jones of Coventry asks: "How do I get past the Balrog in this game? I suspect the phoenix may have something to do with it - but what?"

No, the phoenix has no direct role in this problem. Once you've stolen the sunstone from the altar you're inevitably going to encounter the vile Balrog on the Bridge of Stone. To defeat it you'll need a sword which you should have acquired by placing an emerald eye back into the socket on a statue. 9,18 with the sword to topple the Balrog into the abyss - you'll fall with it but only to a fairly soft landing.

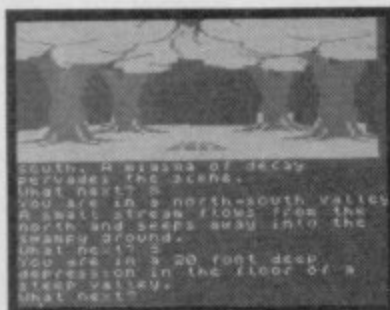

In the underwater section Nick Thorne wants advice on how to defeat a jellyfish and also information about the uses of the bell in the sunken church. The luminous jelly needs to be used rather than destroyed - if you can catch it in a net it will provide valuable light underwater. The net can be found on south beach. Ignore the bell, it's just scenery.

On the lunatic fringes of the world, H Van Der Merwe of Upington SA is far into

## Quest for the Holy Grail

and wails: "I've found the Grail but now I've got to find something to put it on - I can't find the something.

Eternal and knightly gratitude for help."

OK, Sir H, no sweat - try heading for the throne room in Camelot where you'll find the something you're looking for.

David Van Loon (really?) of Leeds has found his way to this room but asks: "The door here keeps closing - I've got a piece of wood but how do I use it to keep the door open?" Pretty much as



you would in real life, Dave. 4,22 will let you through. A crazed Van Loon continues: "I'm also working through

## Kentilla.

How do I enter Tylon's castle and how do I get the Rattling Quarg across the river?"

The Quarg can save you from the deadly tentacles. Getting it over the water is straightforward enough provided you remembered to bring along the rope from the Cavezats' cavern. Just 19,6.

The castle problem is more worrying. To get in, both Zelda and Timandra must still be alive - if they've snuffed it you've failed and won't be able to enter. This is unfortunate but just means you've got to try all over again.

Brad Kincaid of Banbury has managed to get into the castle and has reached Tylon's bedroom. Thus he

grumbles: "In Tylon's castle I've got the graphite and have found the transporter but what do you do in the bedroom? I can't get the key from the bedpost, if that's where it's supposed to be. My computer won't examine anything in the room. Also, what do I do with the crystal? Why does it glow and go dull?"

This is a bit puzzling, really. As far as I know, to get the key you must 1,20 - I'm not aware of any particular conditions that apply to this but, if anyone has an alternative, please let me know and I'll pass the information on.

The crystal is used to overcome the troll, who loathes light. Whilst it's glowing you should put it 2,25,16.

Don't open this until you see the troll - the burst of light will turn the monster to stone. Don't expect this trick to work if you put the crystal in when it's dull.

Still having trouble with the monsters in

## Heavy on the Magic?

Try these tips from Jon Olav Vik of Norway on how to keep them at bay: "All the creatures can be blasted but



there are other ways for the meaner monsters. Use a pellet to slay the slug and a nugget for the werewolf. The

## The Quickies

**Never Ending Story:** Greg McDougall, Birmingham, is infuriated and about to switch off in disgust because he can't get past the spider's web in Part 2. No problem - simply 30,7 and head on through.

**The Hulk:** Dave Mansell, Edgbaston, would like to know how to survive the ants and asks if Antman can be rescued. Sure he can - the ants are potential allies so 29,8. With their aid you should be able to save Antman.

**Terrormolinos:** Stuart Stoneham, East Preston, has tried a thousand times but always fails to get out of the bull-ring. Go to the centre of the ring, 32 and red 24. Now run out of the ring and go S, S, E, N, N, E. The bull should end up as hamburger in a china shop.

**Spellbound:** G Catterall of Newport is making little progress in the gas room. He's consulted the Book of Shadows which tells him he needs two very smelly objects to cast Fumaticus Protectium - where are the objects? He'll need the red herring which can be found in the room to the right of the start and also the Power Pong plant from the basement level. Cast the spell in the basement to allow entry to the gas room.

**Microman:** "I'm stuck in the house" says D McKenzie of Stapleford, "I can't develop the photograph despite trying every way." First of all get the blue, red, magenta and green bottles from the low shelf. Now 1,10. When you've done this 31,11 and 1,10 again. This will allow you to 33,28.

medusa will be petrified by her own reflection in the mirror and the cyclops fears the slat. As usual garlic will deal with a vampire. Apex? Blast away - he'll die finally if you're lucky but why should you want to kill him at all?" Quite.

Andy Bowden of Taunton has been sampling

## Zzzz,

Mastertronic's latest adventure, and suggests for starters: "Go to the beach and dig in the sand with the spade. Lift and get the bucket you find there, then dig again - the sandman will appear but hides again. Head W and push the bike, return to the beach and head E to the snow palace where you should ring the bell. The sandman will now open the



hatch. Give the bike to him and go E to the fridge. There's some cheese in it. If you close the fridge door a chest will appear. Untie the tie and open the chest - there's an unloaded water pistol inside.

"Return to the beach once more, go N and thumb a lift which will take you to a large house. If you knock on the door you'll be told the door remains closed but if you type 'Open door' the door will stay closed and a window opens above. A hand will appear waving a handkerchief."

This is as far as Andy's managed to get - can anyone now continue the tale? Scrolls by first class mule please!

Most of you now seem to have found your way out of the smelly hole in

## The Boggit

and some have even managed to solve my three-letter anagram to destroy the trolls. The serious sticking points are now - of course - the Goblin's Dungeon and the Beholders, then with the nasty eyes. Says Robert Lenson: "After using your advice to pass the trolls, I now need your help in the dungeon. I have the rope and it's tied to the window. How do I get out and how can I find Goldbum?" Phil O'Malley and Allistair Scott of Edinburgh have the same problems but Allistair wants the means to slay the Beholders.

I've got some suitable suggestions from Lorien Kibe of Haughton, Staffs: "In the

# Your key to communications!

Want to join Micronet?  
Need a Modem?  
**LOOK NO FURTHER!**



Micronet are now giving new members a FREE modem  
with their first year's subscription!

VTX 5000 modem with built-in software for Spectrum+, 16k, 48k, +2.

#### **SPECIFICATION**

Baud Rate of 1200/75.

BT Approved.

Built-in Micronet software.

Full Telesoftware download, message preparation, save, send, print  
facilities.

Micronet will give you access to

- Free electronic Mail
- Free and Discounted Telesoftware
- Daily Computer News
- Micronet's famous Chat lines
- Mud Adventures
- Technical advice and features
- Access to BT Gold
- Prestel's\* 350,000 page Database
- 70,000 People

To ensure that you benefit from the best bargain this year, complete the  
application form overleaf and join the communications revolution.

MICRONET, DURRANT HOUSE, 8 HERBAL HILL, LONDON EC1R 5EJ  
TEL: 01-278 3143



# GORDO'S HELPLINE

dungeon throw the rope until it catches against the window, then pull it. Once out take the rope - to guard against being chucked in again, 'cos you probably will be. Now go SW and get the egg. This is essential for a first class ride on the giant eagle. Now NE, SE, E, SE, E. Here you should find the ridge. To reach Goldbum travel N, SE, S from this spot.

"If you want to get rid of the eyes on the forest road, the best thing is to smoke a cigarette.

"All right, now I need to know where the pepper is to get through the morna Gate in

## 'Bored?'

Fair enough - on Featherwop. When you leave the inn at Whee go N and then E a few times to the southern edge of the Tall Mountain. N and Up to reach the summit. Look around and examine carefully.

Now, on with the scuba gear and down to

## Seabase Delta

where Darren Emery, M Jones of Bristol and Paul from Hoyland shriek, "What do I do on the blessed train and what use is the stupid travel permit?"

Simon Ruda of Edware delivers the goods but has questions of his own. First you must 15,21 to activate the car system and then 12,3. Once inside you must wear the seat belt - the vehicle won't move otherwise - and 23,17 to get it under way.

Simon can't switch the conveyor belt on - this can be done with the fork in your possession. Just 14,26. Both Simon and Steven Robinson (thanks for the solutions to Mafia Contract and Espionage Island) are trying to make pancakes without much luck. The answers come from Karl Miles of Castletown in his full solution. First get your egg from the sleepy hen by entering

13,27 at the cage - naturally you'll need the gum. Now all you need is the bowl and some flour and milk.

Further along, Martin Williams of 127 Broadway, Eccleston, St Helens, asks how to open the huge metal sliding doors and keep them open. Once in the room with the microphone, 23,5 go S and then enter the doors.

## INFORMATION EXCHANGE

● Atlantis Software are big adventure producers. If you write to them for help or to order games, note that they've now moved to 28, Station Road, London SE25 5AG.

● Phil Symonds of 29, Goliath Close, Roundshaw, Wallington, Surrey SM6 9HN is willing to correspond and help with a number of games new and old. Drop him a line with an sae if you need help or would like a full list of his solutions.

● Geoff Marshall, 17 Balbeggie Terrace, Dundee, Scotland sent me a list of about 120 (count them!) adventures he's finished and willing to help with - practically every game of note is included. He'll answer questions at the rate of 2p per question plus an sae. Try him out if you're interested.

● If you know how to get the

## Greatbelly Clue Matrix Thingy

- 1: EXAMINE 2: INTO 3: CAR 4: WEDGE 5: CASSETTE
- 6: ROPE 7: WEB 8: ANTS 9: SMITE/ATTACK 10: TRAY
- 11: BOTTLES 12: GO 13 BLOW 14: SHORT 15: PULL
- 16: SACK 17: CARD 18: BRIDGE 19: THROW
- 20: BEDPOST 21: LEVER 22: DOOR 23: INSERT
- 24: HANKY 25: THE 26: SWITCH 27: BUBBLE 28: PAPER
- 29: GET 30: CUT 31: EMPTY 32: WAVE 33: DEVELOP

wax statue in Return to Ithaca let Sandra Sharkey know at 78 Merton Road, Highfield Wigan. In return she can help with games like Valkyrie 17, Ground Zero, Bored, Level Niner's and Artics.

See you next moon.

## GORDO GREAT BELLY

# SINCLAIR user

# COMPETITION

## MURDER AT CRL



## The Competition

A murder has been committed. On the right we present a series of facts about the possible candidates for the guilty party. Using logic, elimination and guesswork you have to pick out, from the information given just who the culprit is.

Fill in the coupon below and send it off pronto to Dead Body Compo, Sinclair User, Priory Court, 30-32 Farringdon Lane, London EC1R 3AU

The guilty party is.....

Name:.....

Address .....

Picture this: Assembled in the drawing room a mixed collection of the rich and famous. And a murder has been committed. A murder which simply oozes with clues but has left the determined but stupid local constabulary baffled. Somewhere amongst the assembled crew is the guilty party, about to get off scot free when... you walk into the spotlight.

You have been able to piece together the clues, your mixture of painstaking investigation, almost telepathic reading of people's inner characters and rigorous deductive logic has enabled you to discover the murderers' true identity. You walk into the spotlight, there is a hush...

Sounds fun? This month **SU** can make it all come true. Because this month we proudly present the **SU** Whodunnit Competition.

First prize a Murder Weekend, where you get to solve a murder by questioning suspects, looking for clues, listening to evidence etc etc. The Murder Weekends are brilliantly devised like an Agatha Christie novel made real. You'll never forget it.

The reason for all this murder and

mahem is the imminent arrival of Murder off Miami, a computer game version of a solve-it-yourself crime book originally devised by Dennis Wheatly.

The game is being created by Fergus McNeil so should be very bizarre indeed. And twenty runners up will also win copies of the game

### The puzzle

My first is in stab and also in slash

My second is in bomb but never in blast

My third is in axe and not in knife

My fourth is in murder but not in death

My fifth is in heat but not in assault

My last is in crimes and also in savage

### Potential Murderers

- 1) Adrian
- 2) Soames
- 3) Sooty
- 4) Sophie
- 5) Stanislavsky



**T**wo worlds – the mirror image of each other, touch in space through a Time-Warp.

**©**ne is positive, good, familiar – our World; the other is negative, evil yet unnervingly familiar.

**T**heir interface – a time window through which objects and beings can pass; contact has resulted in the beginning of exchange.

**R**estore our World – stop the invasion, but do it now, for as the exchange accelerates, the time window grows larger – domination is a hand!

# DOUBLE DON'T TAKE

STARTLING ACTION · INNOVATIVE GAME PLAY · STATE OF THE ART 3-D GRAPHICS

SPECTRUM  
**£7.95**  
 COMMODORE 64  
**£8.95**



6 Central Street • Manchester M2 5NS • Tel: 061 834 3939 • Telex: 669977

# ARCADE

Nichibutsu  
Nichibutsu  
Nichibutsu

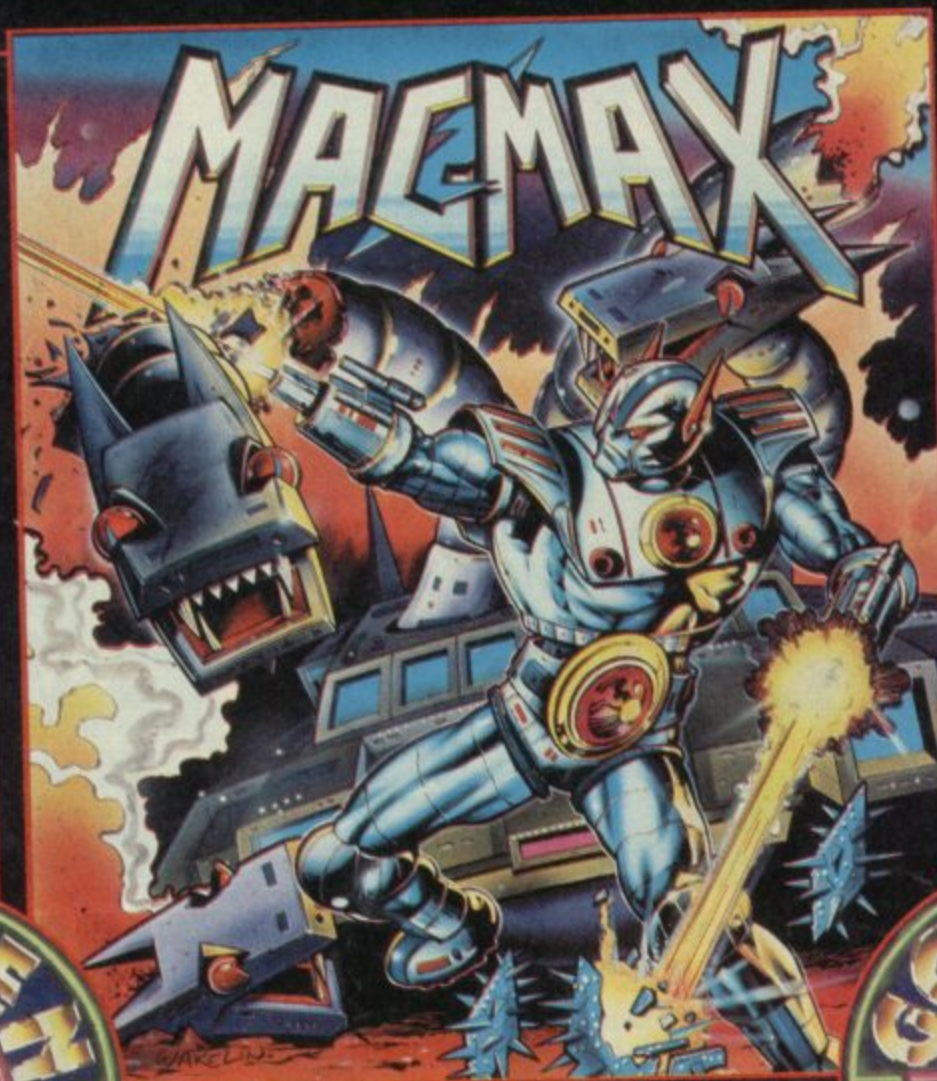

Take control of Mag Max and search the planet for the component parts; As the assembly takes place his power and defences will increase. You will also discover special craters which will transport Max to the underground levels where more dangers lurk.

Armaments consist of Super-Laser with which you must eliminate all aliens and their structures. Defeat or be defeated. Mag Max - robo-centurian.



inhabited  
Alien Life  
impossibl  
Pyramids  
the comp



...the name  
of the game

AMSTRAD 16-BIT



# OF MAGGIC



Galvan the sole surviving member of the Cosmo Police, your imperative assignment is to eliminate all adversaries in the underground Techno Caverns of the planet Cynep. They are led by many Androids, Robots and Defons; your task would seem simple were it not for the Power Crystals scattered at random through the labyrinth.

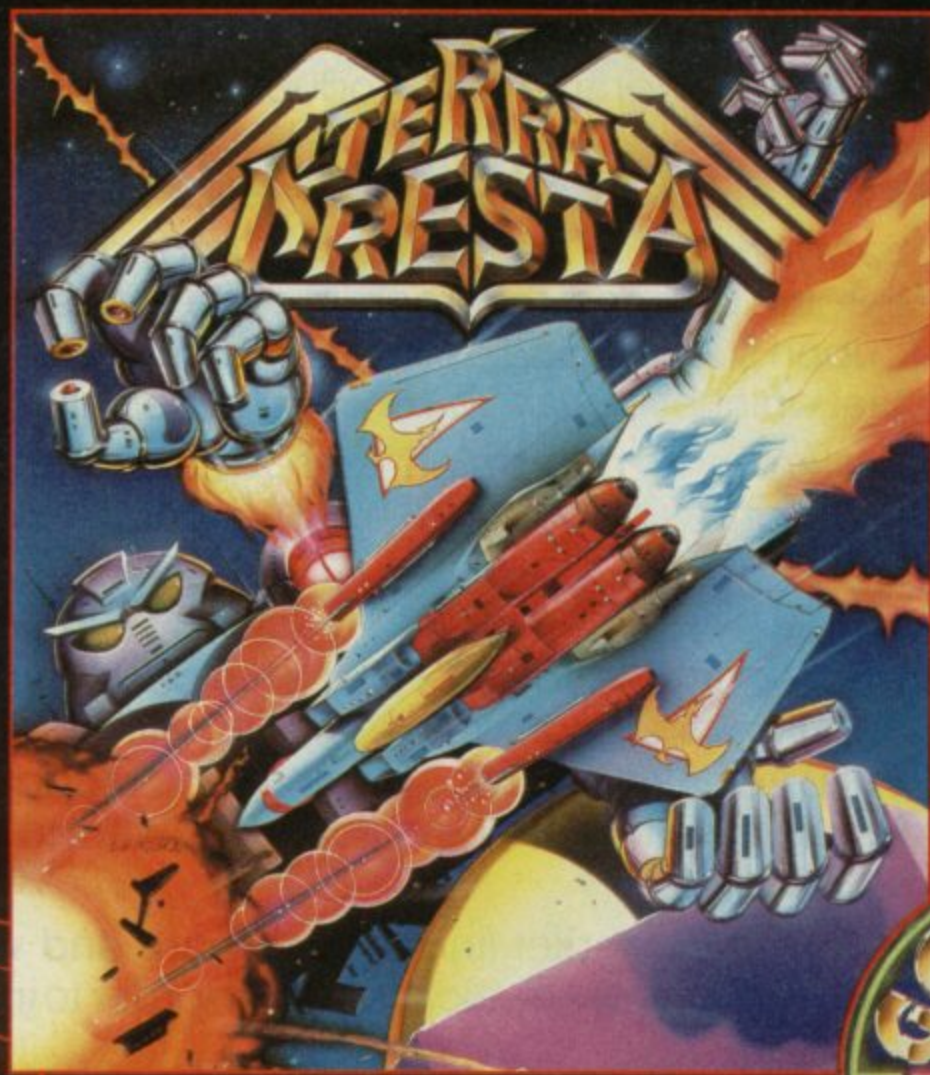

Officially licensed coin-op game from Nichibutsu. Follow up to Moon Cresta. Now for your home computer. Pilot your space fighter over the planet eliminating all alien life forms on its surface. Build up fire power on board as you dodge missiles launched from land silos and under-sea bunkers. Face the giant Death Star at the end of each orbit. You will need nerves of steel to pass this test.



Nichibutsu  
Nichibutsu  
Nichibutsu

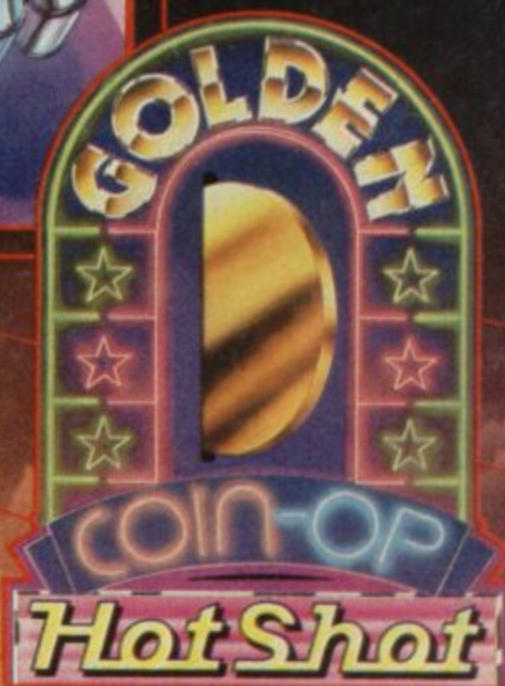

COMMODORE 64 £8.95 SPECTRUM £7.95

# ocean

## OPPORTUNITY KNOCKS

Expansion in an exciting industry.

Continuing success and growth in home computer software creates further positions for personnel in program writing, development and management.

Ocean group markets software worldwide offering the most extensive publication of computer programs and producing maximum sales revenues.

## HOW RICH DO YOU WANT TO BE?

You've probably heard a lot of claims and promises from software companies concerning payment for program code or design work but the fact is reward depends upon success and by linking into success you will achieve your maximum potential whichever way you choose to be paid.

If you have talent and dedication then Ocean with its resources and international connections will bring the fame and fortune you deserve.

## HAVE YOU GOT WHAT IT TAKES?

We are looking for people to work in the fields of game design, graphic animation, program coding and related skills either directly as in-house personnel or on a freelance basis. Training and support will be offered; everything from equipment to friendly advice – we want to help you do a better job for both of us.

We are also looking to market finished software and will offer to translate original programs to every relevant micro format in order to increase the potential revenues to the creator.

We work and publish in both 8 bit and 16 bit environments worldwide and no project is too large or too small for our consideration.

## DON'T MISS THE BOAT

Contact us today in full confidence either by phone, telex, fax or write to:

Product Acquisition and Development,  
Ocean Software Limited,  
6 Central Street,  
Manchester.  
M2 5NS.

Telephone – 061-832 6633

Fax – 061-834 0650

Telex – 669977 OCEANS G.

**EXCLUSIVE**

# FREE elite GAMES

## When you subscribe to SINCLAIR USER

Charity begins with us, forget about the T.V., forget about the Video, forget about the wind up stereo and your dad's 78's. We've just solved all your problems for the whole of 1987.

For just a measley **£15** (if you live in the U.K.!) you can get 12 jam-packed issues of your favourite computer mag.

Noted scientists have recently discovered that if you read every word in each issue at approximately 40,000 times slower than light whilst crossing the equator in Concorde it will leave only 3.333 hours recurring until the next month's issue arrives.

Never fear, to fill in those few desperate hours we're chucking in completely **FREE** one of the new **Elite** games.

Choose between the 3D adventures of **Space Harrier** in the fantasy zone or summon up another scooby snack with **Scooby Doo**, Shaggy and others who nobody ever remembers. Or if you're a real glutton try the **Hit-Pak**, 4 great games in one or the fearsome **Ikari Warriors**.

Simply whack back the coupon to us and we'll send your free game and start your subscription with the issue you request.

1987's gonna be so dull without it!



**SINCLAIR USER/ELITE  
SUBS OFFER**

Please start my subscription from the ..... issue.

Tick appropriate box:

- One year £15 U.K. & Eire
- One year Europe £28;  
£35 Rest of World (Surface Mail)
- One year £60 Rest of World  
(Air Mail)

My choice of FREE Spectrum 48 game is:

- Scooby Doo
- Space Harrier
- Ikari Warriors
- Hit Pak — Commando, Frank Bruno's Boxing, Bombjack, Airwolf.

Your FREE game will be sent under separate cover please allow 28 days.

I enclose my cheque/postal order payable to: **SINCLAIR USER**

for £.....

Please debit my Access/Visa Account  
Amount £..... Expiry Date.....

Card Number.....

Name .....

Address.....

.....

.....

Signed .....

Return to **CARL DUNNE, ELITE SUBS OFFER, Magazine Services Dept, EMAP, 30-32 Farringdon Lane, LONDON EC1R 3AU.**

**T**he Pawn, it cannot have escaped your attention, has had some pretty good reviews. Actually on every one of its editions from the QL original, through the Amiga and Atari ST to the Commodore 64 it's had the sort of reactions that caused the prefix mega to be invented.

What is it? Well it's a graphics adventure except that on the Spectrum 128K it doesn't have any graphics.

This is a shame because the graphics on ST were staggering, even the graphics on the C64 were good. Blame the fact that the 128 doesn't have a disc.

What are you left with when you take away the graphics from **The Pawn**? Probably the only adventure to seriously compete with the best Infocom offerings in terms of sentence analysis (all that 'put the small frog in my pocket under the tree trunk then insert the gold key, open the box and keep all except the cuddly toy' stuff) and, let us not forget, wit. That's all.

You see there are serious adventures and there are funny adventures.

Serious adventures seriously depict serious battles between good and evil and have characters, places and objects with names that are either a) stolen from very bad fantasy novels or b) apparently based on names of kitchen cleaning materials.

Funny adventures, with the exception of most (but not all) of Fergus McNeil's stuff aren't funny. Funny adventures that aren't funny are even worse than serious adventures.

**The Pawn**, however, is serious and funny at the same time. That is, it maintains a constant balance between being an adventure that you can play as a serious challenge and also being an adventure that is aware of the pitfalls and cliches and avoids and/or twists them.

Take Princesses for example. Princess are for rescuing (being poor weak women and all that, facing fates worse than death). There is a Princess in **The Pawn** but... well... she's a bit of a pain actually.

# PAWVN

The plot. Well there isn't actually a plot - there's more of an overall concept. Kerovnia (as names for mystic lands go this is not too bad since it merely sounds like some Slavic state currently under Soviet control) is politically wobbly and King Erik looks to be on the way out (who can respect a king called Erik) partly because of his having made the Roobikyoub dwarfs persona non gratis.

The dwarfs are notoriously unsound but brew excellent whisky and... well... I think you get the idea. You arrive in time to steer events a number of different ways, it's just that

some actions will result in your death.

**The Pawn**, is obviously considerably more sophisticated than the usual *Go North, Eat Frog* stuff. I remember Anita Sinclair (Magnetic Scroll's quazi-femme fatale) demonstrating the various ways of refering to different keys that could be either in her pocket or a tree trunk. Her enthusiasm was not so much contagious as exhausting. What it all means and why it matters is simply that you can come that little bit

closer with **The Pawn** to actually typing normal English

SINCLAIR USER  
**CLASSIC**

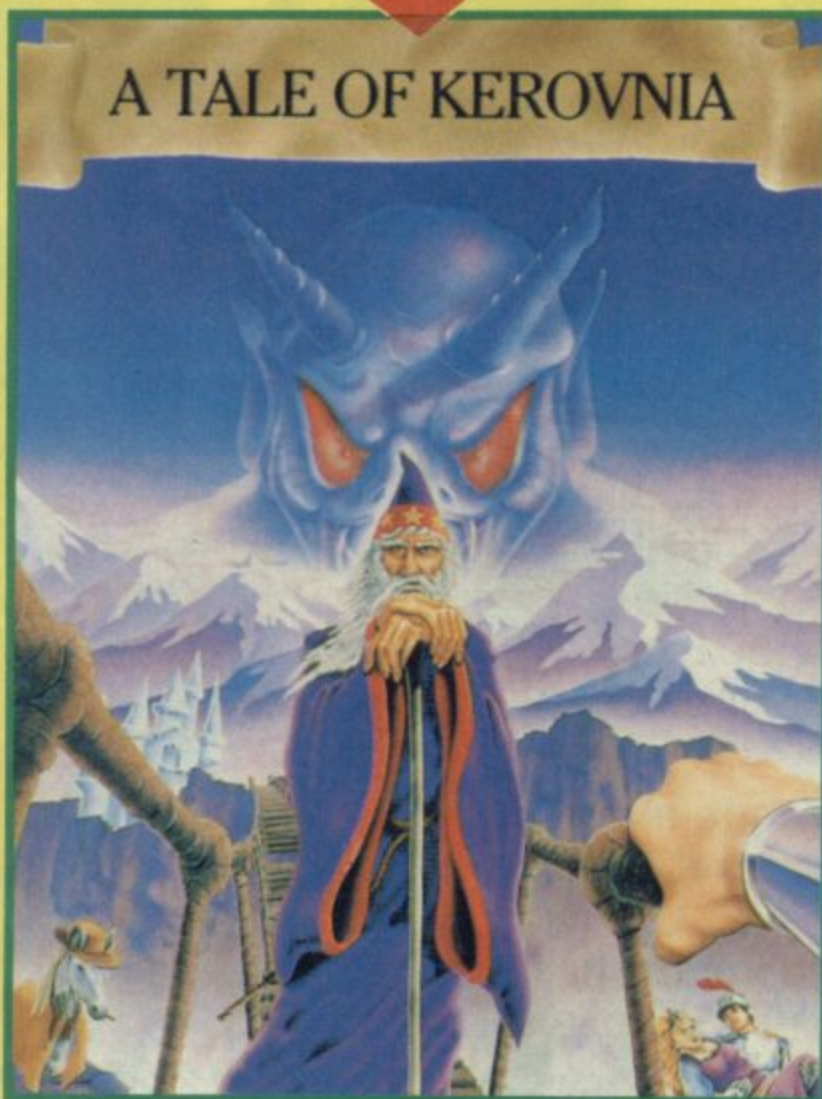

## FACTS BOX

An essential purchase for anyone into adventures who has just upgraded to a 128 - it doesn't run on a 48K

### THE PAWVN

Label: Rainbird  
Author: Magnetic Scrolls  
Price: £14.95  
Memory: 128K

Reviewer: *Graham Taylor*



sentences. You are also less likely to get idiotic responses to perfectly reasonable (if incorrect) instructions.

There are a lot of ways of playing **The Pawn**. It is possible to wander around quite a wide area not having solved much but just enjoying the text comments and ludicrous set pieces. Try having a sensible conversation with the guru to kick off with. It can get pretty unsettling. You could go straight for the serious problem solving, or you could just opt for some of the offers you get to take on minor quests from assorted dubious characters you meet on your travels. Some of these quests sound simple (delivering the odd sealed letter), although usually there is a problem that means it isn't as simple as it seems.

What else? **The Pawn** has an in-built clue system where, by entering codes from the back of the manual, you can get hints on particular problems.

It's very expensive but worth it. And it is also one of the very few programs which will *only* work on the 128K machine, so it's a nice treat if you've just invested in a 128K+2.

Long atmospheric location descriptions are a key feature of the Pawn. That and what is probably the most sophisticated text parser this side of Infocom (or even the other side for that matter!) Sad though that the fabulous graphics from the ST version could not be included.

### ON THE PATH

The Pawn - Copyright (c) 1985,1986 Magnetic Scrolls Ltd.

Version 0.99

You wake up on a sunny August morning with birds singing, and the air fresh and clear. However, your joints are stiff and you have not woken up in your bedroom as you would have expected. Trying to recall what happened the night before, you manage to piece together a few brief glimpses to give the following account:

You were walking home, having just done your week's shopping at the supermarket, when you noticed a stranger in a white overcoat coming towards you. When he got very close you noticed that he was wearing glasses and had a thick, bushy beard. As he passed you, he let out a hollow, cackling laugh and you felt a sharp blow on the back of your head. Then you woke up. You now notice that you are wearing a silver wristband which covers your forearm.

On The Path

0/0

### HELL

140/738

A fridge is embedded in the south wall near one exit, the only other exit being down a steep passage in the east wall.

The demons are busy gorging themselves making a lot of mess in the process.

>go to hell

Hell

You are in the bubbling fire-pit of hell. Small geysers dotted at irregular intervals randomly spout their vitriol into the crackling atmosphere. Sharp, shining scythes, making deadly sweeping motions at head height, hang in front of you, suspended by some indiscernible force. Amongst this chaos stands an immense throne sitting upon which is a horrible being covered in thick black fur with terrible fiery eyes. The terrible eyes seem to be speaking to you in some sort of empathic transmission. It takes you a while to figure out what they are trying to say but eventually you get the message - they are saying "Hello".

>ask devil about life, the universe and everything



## REVIEW

# DOME TROOPER

Quilled and independent, fast and slick ● Outside the dome ● Dare you venture inside? ● It's the only way to go and quick, I'd say

These days everyone seems to be writing their own adventure. And, some of these 'indi' home-made efforts – often available only by mail-order – turn out to be well-impressive, too.

In any adventure it's the plot that either makes or breaks it – and the big firms certainly don't have a monopoly on ideas.

Using an adventure writing system – as most of these 'indi' efforts do (either *The Quill* or *GAC*) – anyone can compete and follow in the footsteps of famous authors like Fergus McNeil or the St Brides team

**D**ome Trooper is excellent. It's Quilled, like so many independent adventures, but it has a highly original plot which is both well thought out and executed.

The *Illustrator* has been used to provide graphics that complement the adventure, and the author has made clever use of the special features such as the *Flash* command – at one point, a huge CocaCola sign flashed on and off above a futuristic equivalent of Piccadilly Circus.

It is the far future: humanity seems to have become divided into two factions, the people who live in the domed cities and the evil barbaric hordes who infest the desert outside.

You know enemy agents within your beloved city have been told to poison the city's air and water supplies with a

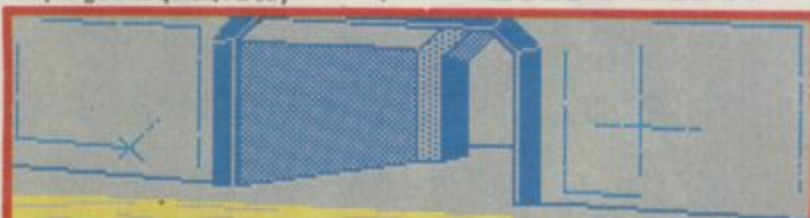

YOU STAND ON THE SOFT SANDS OF THE NEUTRAL ZONE. THE SUN BEATS DOWN WITH NO MERCY. TO THE SOUTH IS THE ENTRANCE TO CITY DOME ALPHA. THE DOME IS COLOSSAL IN SIZE. TO THE NORTH, EAST AND WEST IS THE CITY'S DEFENCE WALL. AWAITING LOGIC INPUT

terrible drug that will kill everybody within days.

So here you are, armed with your trusty blaster, standing on the edge of the desert outside City Dome Alpha. What now? Well, you could boldly stride into the desert and take on the

## FACTS BOX

*Nice one. Lots of invention, neat puzzles of about the right level of difficulty. And it's really cheap*

## DOME TROOPER

Label: Matand  
29 Moorland Road, Michelover, Derby

Author: M. Holmes

Price: £2.95

Memory: 48K/128K

Reviewer: *Gams Rook*



# PREHISTORIC ADVENTURE

**C**rusader Computing's *Prehistoric Adventure* is a well crafted adventure that includes an element of – horrors – education!! You get to learn about dinosaurs while solving the problems. They're big.

Actually, even armed with the clue sheet all I've seen so far is a dinosaur bone, but I'm sure I'll come across them soon.

Basically, you have to get to the island of dinosaurs to find the main ingredient for the

## FACTS BOX

*Very professionally presented effort. It's a toughy though and, despite the full-colour poster, it's quite pricey*

## PREHISTORIC ADVENTURE

Label: Crusader  
18 Henley Wood Road, Earley, Reading, Berks

Price: £9.95

Memory: 48K/128K

Reviewer: *Gams Rook*



The Trader says "Good morning".

SW

The road now slopes from the north-east down to the sea, far to the south. Exits lead south, north-east, down.

S

Standing at the quayside, the smell of the crisp salt air attracts you to the open sea beyond. Exits lead up, south, north.

There is a yacht here.

board yacht

You are on board the boat. Exits lead in many directions.

potion of eternal life which has kept the old man in the centre of Stonehenge young for centuries...

You kick off in a high class burger bar with a dress code and American Express sign in the window. You'll need the burger later, along with something to quench the thirst, otherwise it'll be a case of water, water everywhere...

Finding the map is a bit of a pain. First map the endless plains, then find the coppice. Use the rod to find the underground stream. And with

a bit of manual labour, you'll have your map.

There are a number of problems in the first section of the game – the bit that happens before you reach the island, that is – and they're all pretty tough. I think they might be just a bit too tough, but I suppose you'll at least be kept busy.

Included with the game you get a dinosaur poster so you can spot who's who when you finally get to the lost world. Even so, I can't help feeling that £9.95 is a bit steep for a text-only adventure.

KONAMI'S  
COIN-OP HITS

# FIVE GREAT ARCADE GAMES FOR THE PRICE OF ONE

IT MUST BE CHRISTMAS

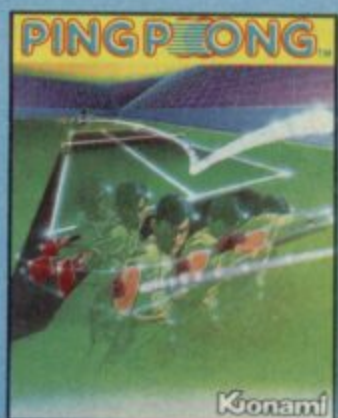
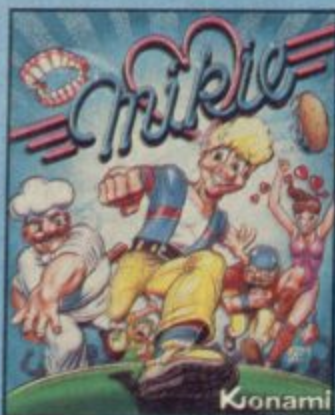
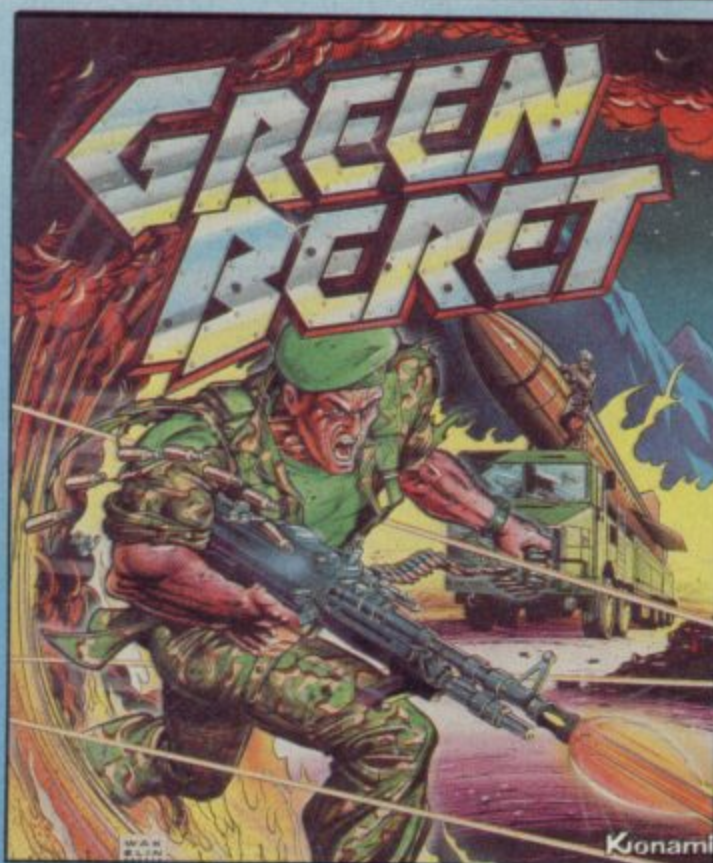
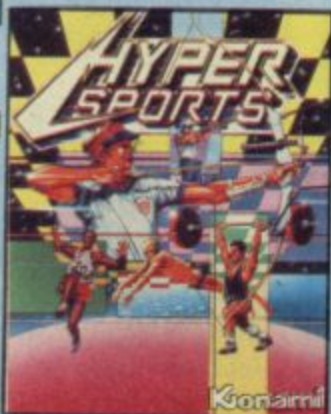

## KONAMI'S COIN-OP HITS

	Cassette	Disk
SPECTRUM	£9.95	-
COMMODORE	£9.95	£14.95
AMSTRAD	£9.95	£14.95

Twin Cassette Pack

**Imagine**  
...the name  
of the game

# Meet the printer interface with a gift for words.

Before you buy a printer interface, it's worth thinking ahead. One day, you'll probably want to write someone a letter. Draft an essay. Or create a report.

With RamPrint, it couldn't be simpler.

RamPrint gives you a powerful interface to the huge range of popular Centronics printers.

It's also the only interface with RamWrite 'Instant Access' word processing built in.

Plug in a printer and you're ready to create, edit and save professional-looking documents, quickly and easily.

The RamWrite program uses 'Instant Access' so there's no software to load, and takes none of the computer's precious memory. In fact, it's the simplest way to write a letter on the Spectrum.

The cost: just £54.95 (cheaper than buying an interface and software separately). We've included the printer cable - and even a joystick port so you can play games without unplugging.

To get your hands on one, simply fill in the coupon. Whichever way you look at it, it's a gift.

```

RAM TO 2000
100 LET A=1
110 LET B=1
120 PRINT "RAMPRINT"
130 GOTO 140
140 PRINT "RAMPRINT"
150 GOTO 160
160 PRINT "RAMPRINT"
170 GOTO 180
180 PRINT "RAMPRINT"
190 GOTO 200
200 LET A=2
210 LET B=2
220 PRINT "RAMPRINT"
230 GOTO 240
240 PRINT "RAMPRINT"
250 GOTO 260
260 PRINT "RAMPRINT"
270 GOTO 280
280 PRINT "RAMPRINT"
290 GOTO 300
300 LET A=3
310 LET B=3
320 PRINT "RAMPRINT"
330 GOTO 340
340 PRINT "RAMPRINT"
350 GOTO 360
360 PRINT "RAMPRINT"
370 GOTO 380
380 PRINT "RAMPRINT"
390 GOTO 400
400 LET A=4
410 LET B=4
420 PRINT "RAMPRINT"
430 GOTO 440
440 PRINT "RAMPRINT"
450 GOTO 460
460 PRINT "RAMPRINT"
470 GOTO 480
480 PRINT "RAMPRINT"
490 GOTO 500
500 LET A=5
510 LET B=5
520 PRINT "RAMPRINT"
530 GOTO 540
540 PRINT "RAMPRINT"
550 GOTO 560
560 PRINT "RAMPRINT"
570 GOTO 580
580 PRINT "RAMPRINT"
590 GOTO 600
600 LET A=6
610 LET B=6
620 PRINT "RAMPRINT"
630 GOTO 640
640 PRINT "RAMPRINT"
650 GOTO 660
660 PRINT "RAMPRINT"
670 GOTO 680
680 PRINT "RAMPRINT"
690 GOTO 700
700 LET A=7
710 LET B=7
720 PRINT "RAMPRINT"
730 GOTO 740
740 PRINT "RAMPRINT"
750 GOTO 760
760 PRINT "RAMPRINT"
770 GOTO 780
780 PRINT "RAMPRINT"
790 GOTO 800
800 LET A=8
810 LET B=8
820 PRINT "RAMPRINT"
830 GOTO 840
840 PRINT "RAMPRINT"
850 GOTO 860
860 PRINT "RAMPRINT"
870 GOTO 880
880 PRINT "RAMPRINT"
890 GOTO 900
900 LET A=9
910 LET B=9
920 PRINT "RAMPRINT"
930 GOTO 940
940 PRINT "RAMPRINT"
950 GOTO 960
960 PRINT "RAMPRINT"
970 GOTO 980
980 PRINT "RAMPRINT"
990 GOTO 1000
1000 LET A=10
1010 LET B=10
1020 PRINT "RAMPRINT"
1030 GOTO 1040
1040 PRINT "RAMPRINT"
1050 GOTO 1060
1060 PRINT "RAMPRINT"
1070 GOTO 1080
1080 PRINT "RAMPRINT"
1090 GOTO 1100
1100 LET A=11
1110 LET B=11
1120 PRINT "RAMPRINT"
1130 GOTO 1140
1140 PRINT "RAMPRINT"
1150 GOTO 1160
1160 PRINT "RAMPRINT"
1170 GOTO 1180
1180 PRINT "RAMPRINT"
1190 GOTO 1200
1200 LET A=12
1210 LET B=12
1220 PRINT "RAMPRINT"
1230 GOTO 1240
1240 PRINT "RAMPRINT"
1250 GOTO 1260
1260 PRINT "RAMPRINT"
1270 GOTO 1280
1280 PRINT "RAMPRINT"
1290 GOTO 1300
1300 LET A=13
1310 LET B=13
1320 PRINT "RAMPRINT"
1330 GOTO 1340
1340 PRINT "RAMPRINT"
1350 GOTO 1360
1360 PRINT "RAMPRINT"
1370 GOTO 1380
1380 PRINT "RAMPRINT"
1390 GOTO 1400
1400 LET A=14
1410 LET B=14
1420 PRINT "RAMPRINT"
1430 GOTO 1440
1440 PRINT "RAMPRINT"
1450 GOTO 1460
1460 PRINT "RAMPRINT"
1470 GOTO 1480
1480 PRINT "RAMPRINT"
1490 GOTO 1500
1500 LET A=15
1510 LET B=15
1520 PRINT "RAMPRINT"
1530 GOTO 1540
1540 PRINT "RAMPRINT"
1550 GOTO 1560
1560 PRINT "RAMPRINT"
1570 GOTO 1580
1580 PRINT "RAMPRINT"
1590 GOTO 1600
1600 LET A=16
1610 LET B=16
1620 PRINT "RAMPRINT"
1630 GOTO 1640
1640 PRINT "RAMPRINT"
1650 GOTO 1660
1660 PRINT "RAMPRINT"
1670 GOTO 1680
1680 PRINT "RAMPRINT"
1690 GOTO 1700
1700 LET A=17
1710 LET B=17
1720 PRINT "RAMPRINT"
1730 GOTO 1740
1740 PRINT "RAMPRINT"
1750 GOTO 1760
1760 PRINT "RAMPRINT"
1770 GOTO 1780
1780 PRINT "RAMPRINT"
1790 GOTO 1800
1800 LET A=18
1810 LET B=18
1820 PRINT "RAMPRINT"
1830 GOTO 1840
1840 PRINT "RAMPRINT"
1850 GOTO 1860
1860 PRINT "RAMPRINT"
1870 GOTO 1880
1880 PRINT "RAMPRINT"
1890 GOTO 1900
1900 LET A=19
1910 LET B=19
1920 PRINT "RAMPRINT"
1930 GOTO 1940
1940 PRINT "RAMPRINT"
1950 GOTO 1960
1960 PRINT "RAMPRINT"
1970 GOTO 1980
1980 PRINT "RAMPRINT"
1990 GOTO 2000
2000 LET A=20
2010 LET B=20
2020 PRINT "RAMPRINT"
2030 GOTO 2040
2040 PRINT "RAMPRINT"
2050 GOTO 2060
2060 PRINT "RAMPRINT"
2070 GOTO 2080
2080 PRINT "RAMPRINT"
2090 GOTO 2100
2100 LET A=21
2110 LET B=21
2120 PRINT "RAMPRINT"
2130 GOTO 2140
2140 PRINT "RAMPRINT"
2150 GOTO 2160
2160 PRINT "RAMPRINT"
2170 GOTO 2180
2180 PRINT "RAMPRINT"
2190 GOTO 2200
2200 LET A=22
2210 LET B=22
2220 PRINT "RAMPRINT"
2230 GOTO 2240
2240 PRINT "RAMPRINT"
2250 GOTO 2260
2260 PRINT "RAMPRINT"
2270 GOTO 2280
2280 PRINT "RAMPRINT"
2290 GOTO 2300
2300 LET A=23
2310 LET B=23
2320 PRINT "RAMPRINT"
2330 GOTO 2340
2340 PRINT "RAMPRINT"
2350 GOTO 2360
2360 PRINT "RAMPRINT"
2370 GOTO 2380
2380 PRINT "RAMPRINT"
2390 GOTO 2400
2400 LET A=24
2410 LET B=24
2420 PRINT "RAMPRINT"
2430 GOTO 2440
2440 PRINT "RAMPRINT"
2450 GOTO 2460
2460 PRINT "RAMPRINT"
2470 GOTO 2480
2480 PRINT "RAMPRINT"
2490 GOTO 2500
2500 LET A=25
2510 LET B=25
2520 PRINT "RAMPRINT"
2530 GOTO 2540
2540 PRINT "RAMPRINT"
2550 GOTO 2560
2560 PRINT "RAMPRINT"
2570 GOTO 2580
2580 PRINT "RAMPRINT"
2590 GOTO 2600
2600 LET A=26
2610 LET B=26
2620 PRINT "RAMPRINT"
2630 GOTO 2640
2640 PRINT "RAMPRINT"
2650 GOTO 2660
2660 PRINT "RAMPRINT"
2670 GOTO 2680
2680 PRINT "RAMPRINT"
2690 GOTO 2700
2700 LET A=27
2710 LET B=27
2720 PRINT "RAMPRINT"
2730 GOTO 2740
2740 PRINT "RAMPRINT"
2750 GOTO 2760
2760 PRINT "RAMPRINT"
2770 GOTO 2780
2780 PRINT "RAMPRINT"
2790 GOTO 2800
2800 LET A=28
2810 LET B=28
2820 PRINT "RAMPRINT"
2830 GOTO 2840
2840 PRINT "RAMPRINT"
2850 GOTO 2860
2860 PRINT "RAMPRINT"
2870 GOTO 2880
2880 PRINT "RAMPRINT"
2890 GOTO 2900
2900 LET A=29
2910 LET B=29
2920 PRINT "RAMPRINT"
2930 GOTO 2940
2940 PRINT "RAMPRINT"
2950 GOTO 2960
2960 PRINT "RAMPRINT"
2970 GOTO 2980
2980 PRINT "RAMPRINT"
2990 GOTO 3000
3000 LET A=30
3010 LET B=30
3020 PRINT "RAMPRINT"
3030 GOTO 3040
3040 PRINT "RAMPRINT"
3050 GOTO 3060
3060 PRINT "RAMPRINT"
3070 GOTO 3080
3080 PRINT "RAMPRINT"
3090 GOTO 3100
3100 LET A=31
3110 LET B=31
3120 PRINT "RAMPRINT"
3130 GOTO 3140
3140 PRINT "RAMPRINT"
3150 GOTO 3160
3160 PRINT "RAMPRINT"
3170 GOTO 3180
3180 PRINT "RAMPRINT"
3190 GOTO 3200
3200 LET A=32
3210 LET B=32
3220 PRINT "RAMPRINT"
3230 GOTO 3240
3240 PRINT "RAMPRINT"
3250 GOTO 3260
3260 PRINT "RAMPRINT"
3270 GOTO 3280
3280 PRINT "RAMPRINT"
3290 GOTO 3300
3300 LET A=33
3310 LET B=33
3320 PRINT "RAMPRINT"
3330 GOTO 3340
3340 PRINT "RAMPRINT"
3350 GOTO 3360
3360 PRINT "RAMPRINT"
3370 GOTO 3380
3380 PRINT "RAMPRINT"
3390 GOTO 3400
3400 LET A=34
3410 LET B=34
3420 PRINT "RAMPRINT"
3430 GOTO 3440
3440 PRINT "RAMPRINT"
3450 GOTO 3460
3460 PRINT "RAMPRINT"
3470 GOTO 3480
3480 PRINT "RAMPRINT"
3490 GOTO 3500
3500 LET A=35
3510 LET B=35
3520 PRINT "RAMPRINT"
3530 GOTO 3540
3540 PRINT "RAMPRINT"
3550 GOTO 3560
3560 PRINT "RAMPRINT"
3570 GOTO 3580
3580 PRINT "RAMPRINT"
3590 GOTO 3600
3600 LET A=36
3610 LET B=36
3620 PRINT "RAMPRINT"
3630 GOTO 3640
3640 PRINT "RAMPRINT"
3650 GOTO 3660
3660 PRINT "RAMPRINT"
3670 GOTO 3680
3680 PRINT "RAMPRINT"
3690 GOTO 3700
3700 LET A=37
3710 LET B=37
3720 PRINT "RAMPRINT"
3730 GOTO 3740
3740 PRINT "RAMPRINT"
3750 GOTO 3760
3760 PRINT "RAMPRINT"
3770 GOTO 3780
3780 PRINT "RAMPRINT"
3790 GOTO 3800
3800 LET A=38
3810 LET B=38
3820 PRINT "RAMPRINT"
3830 GOTO 3840
3840 PRINT "RAMPRINT"
3850 GOTO 3860
3860 PRINT "RAMPRINT"
3870 GOTO 3880
3880 PRINT "RAMPRINT"
3890 GOTO 3900
3900 LET A=39
3910 LET B=39
3920 PRINT "RAMPRINT"
3930 GOTO 3940
3940 PRINT "RAMPRINT"
3950 GOTO 3960
3960 PRINT "RAMPRINT"
3970 GOTO 3980
3980 PRINT "RAMPRINT"
3990 GOTO 4000
4000 LET A=40
4010 LET B=40
4020 PRINT "RAMPRINT"
4030 GOTO 4040
4040 PRINT "RAMPRINT"
4050 GOTO 4060
4060 PRINT "RAMPRINT"
4070 GOTO 4080
4080 PRINT "RAMPRINT"
4090 GOTO 4100
4100 LET A=41
4110 LET B=41
4120 PRINT "RAMPRINT"
4130 GOTO 4140
4140 PRINT "RAMPRINT"
4150 GOTO 4160
4160 PRINT "RAMPRINT"
4170 GOTO 4180
4180 PRINT "RAMPRINT"
4190 GOTO 4200
4200 LET A=42
4210 LET B=42
4220 PRINT "RAMPRINT"
4230 GOTO 4240
4240 PRINT "RAMPRINT"
4250 GOTO 4260
4260 PRINT "RAMPRINT"
4270 GOTO 4280
4280 PRINT "RAMPRINT"
4290 GOTO 4300
4300 LET A=43
4310 LET B=43
4320 PRINT "RAMPRINT"
4330 GOTO 4340
4340 PRINT "RAMPRINT"
4350 GOTO 4360
4360 PRINT "RAMPRINT"
4370 GOTO 4380
4380 PRINT "RAMPRINT"
4390 GOTO 4400
4400 LET A=44
4410 LET B=44
4420 PRINT "RAMPRINT"
4430 GOTO 4440
4440 PRINT "RAMPRINT"
4450 GOTO 4460
4460 PRINT "RAMPRINT"
4470 GOTO 4480
4480 PRINT "RAMPRINT"
4490 GOTO 4500
4500 LET A=45
4510 LET B=45
4520 PRINT "RAMPRINT"
4530 GOTO 4540
4540 PRINT "RAMPRINT"
4550 GOTO 4560
4560 PRINT "RAMPRINT"
4570 GOTO 4580
4580 PRINT "RAMPRINT"
4590 GOTO 4600
4600 LET A=46
4610 LET B=46
4620 PRINT "RAMPRINT"
4630 GOTO 4640
4640 PRINT "RAMPRINT"
4650 GOTO 4660
4660 PRINT "RAMPRINT"
4670 GOTO 4680
4680 PRINT "RAMPRINT"
4690 GOTO 4700
4700 LET A=47
4710 LET B=47
4720 PRINT "RAMPRINT"
4730 GOTO 4740
4740 PRINT "RAMPRINT"
4750 GOTO 4760
4760 PRINT "RAMPRINT"
4770 GOTO 4780
4780 PRINT "RAMPRINT"
4790 GOTO 4800
4800 LET A=48
4810 LET B=48
4820 PRINT "RAMPRINT"
4830 GOTO 4840
4840 PRINT "RAMPRINT"
4850 GOTO 4860
4860 PRINT "RAMPRINT"
4870 GOTO 4880
4880 PRINT "RAMPRINT"
4890 GOTO 4900
4900 LET A=49
4910 LET B=49
4920 PRINT "RAMPRINT"
4930 GOTO 4940
4940 PRINT "RAMPRINT"
4950 GOTO 4960
4960 PRINT "RAMPRINT"
4970 GOTO 4980
4980 PRINT "RAMPRINT"
4990 GOTO 5000
5000 LET A=50
5010 LET B=50
5020 PRINT "RAMPRINT"
5030 GOTO 5040
5040 PRINT "RAMPRINT"
5050 GOTO 5060
5060 PRINT "RAMPRINT"
5070 GOTO 5080
5080 PRINT "RAMPRINT"
5090 GOTO 5100
5100 LET A=51
5110 LET B=51
5120 PRINT "RAMPRINT"
5130 GOTO 5140
5140 PRINT "RAMPRINT"
5150 GOTO 5160
5160 PRINT "RAMPRINT"
5170 GOTO 5180
5180 PRINT "RAMPRINT"
5190 GOTO 5200
5200 LET A=52
5210 LET B=52
5220 PRINT "RAMPRINT"
5230 GOTO 5240
5240 PRINT "RAMPRINT"
5250 GOTO 5260
5260 PRINT "RAMPRINT"
5270 GOTO 5280
5280 PRINT "RAMPRINT"
5290 GOTO 5300
5300 LET A=53
5310 LET B=53
5320 PRINT "RAMPRINT"
5330 GOTO 5340
5340 PRINT "RAMPRINT"
5350 GOTO 5360
5360 PRINT "RAMPRINT"
5370 GOTO 5380
5380 PRINT "RAMPRINT"
5390 GOTO 5400
5400 LET A=54
5410 LET B=54
5420 PRINT "RAMPRINT"
5430 GOTO 5440
5440 PRINT "RAMPRINT"
5450 GOTO 5460
5460 PRINT "RAMPRINT"
5470 GOTO 5480
5480 PRINT "RAMPRINT"
5490 GOTO 5500
5500 LET A=55
5510 LET B=55
5520 PRINT "RAMPRINT"
5530 GOTO 5540
5540 PRINT "RAMPRINT"
5550 GOTO 5560
5560 PRINT "RAMPRINT"
5570 GOTO 5580
5580 PRINT "RAMPRINT"
5590 GOTO 5600
5600 LET A=56
5610 LET B=56
5620 PRINT "RAMPRINT"
5630 GOTO 5640
5640 PRINT "RAMPRINT"
5650 GOTO 5660
5660 PRINT "RAMPRINT"
5670 GOTO 5680
5680 PRINT "RAMPRINT"
5690 GOTO 5700
5700 LET A=57
5710 LET B=57
5720 PRINT "RAMPRINT"
5730 GOTO 5740
5740 PRINT "RAMPRINT"
5750 GOTO 5760
5760 PRINT "RAMPRINT"
5770 GOTO 5780
5780 PRINT "RAMPRINT"
5790 GOTO 5800
5800 LET A=58
5810 LET B=58
5820 PRINT "RAMPRINT"
5830 GOTO 5840
5840 PRINT "RAMPRINT"
5850 GOTO 5860
5860 PRINT "RAMPRINT"
5870 GOTO 5880
5880 PRINT "RAMPRINT"
5890 GOTO 5900
5900 LET A=59
5910 LET B=59
5920 PRINT "RAMPRINT"
5930 GOTO 5940
5940 PRINT "RAMPRINT"
5950 GOTO 5960
5960 PRINT "RAMPRINT"
5970 GOTO 5980
5980 PRINT "RAMPRINT"
5990 GOTO 6000
6000 LET A=60
6010 LET B=60
6020 PRINT "RAMPRINT"
6030 GOTO 6040
6040 PRINT "RAMPRINT"
6050 GOTO 6060
6060 PRINT "RAMPRINT"
6070 GOTO 6080
6080 PRINT "RAMPRINT"
6090 GOTO 6100
6100 LET A=61
6110 LET B=61
6120 PRINT "RAMPRINT"
6130 GOTO 6140
6140 PRINT "RAMPRINT"
6150 GOTO 6160
6160 PRINT "RAMPRINT"
6170 GOTO 6180
6180 PRINT "RAMPRINT"
6190 GOTO 6200
6200 LET A=62
6210 LET B=62
6220 PRINT "RAMPRINT"
6230 GOTO 6240
6240 PRINT "RAMPRINT"
6250 GOTO 6260
6260 PRINT "RAMPRINT"
6270 GOTO 6280
6280 PRINT "RAMPRINT"
6290 GOTO 6300
6300 LET A=63
6310 LET B=63
6320 PRINT "RAMPRINT"
6330 GOTO 6340
6340 PRINT "RAMPRINT"
6350 GOTO 6360
6360 PRINT "RAMPRINT"
6370 GOTO 6380
6380 PRINT "RAMPRINT"
6390 GOTO 6400
6400 LET A=64
6410 LET B=64
6420 PRINT "RAMPRINT"
6430 GOTO 6440
6440 PRINT "RAMPRINT"
6450 GOTO 6460
6460 PRINT "RAMPRINT"
6470 GOTO 6480
6480 PRINT "RAMPRINT"
6490 GOTO 6500
6500 LET A=65
6510 LET B=65
6520 PRINT "RAMPRINT"
6530 GOTO 6540
6540 PRINT "RAMPRINT"
6550 GOTO 6560
6560 PRINT "RAMPRINT"
6570 GOTO 6580
6580 PRINT "RAMPRINT"
6590 GOTO 6600
6600 LET A=66
6610 LET B=66
6620 PRINT "RAMPRINT"
6630 GOTO 6640
6640 PRINT "RAMPRINT"
6650 GOTO 6660
6660 PRINT "RAMPRINT"
6670 GOTO 6680
6680 PRINT "RAMPRINT"
6690 GOTO 6700
6700 LET A=67
6710 LET B=67
6720 PRINT "RAMPRINT"
6730 GOTO 6740
6740 PRINT "RAMPRINT"
6750 GOTO 6760
6760 PRINT "RAMPRINT"
6770 GOTO 6780
6780 PRINT "RAMPRINT"
6790 GOTO 6800
6800 LET A=68
6810 LET B=68
6820 PRINT "RAMPRINT"
6830 GOTO 6840
6840 PRINT "RAMPRINT"
6850 GOTO 6860
6860 PRINT "RAMPRINT"
6870 GOTO 6880
6880 PRINT "RAMPRINT"
6890 GOTO 6900
6900 LET A=69
6910 LET B=69
6920 PRINT "RAMPRINT"
6930 GOTO 6940
6940 PRINT "RAMPRINT"
6950 GOTO 6960
6960 PRINT "RAMPRINT"
6970 GOTO 6980
6980 PRINT "RAMPRINT"
6990 GOTO 7000
7000 LET A=70
7010 LET B=70
7020 PRINT "RAMPRINT"
7030 GOTO 7040
7040 PRINT "RAMPRINT"
7050 GOTO 7060
7060 PRINT "RAMPRINT"
7070 GOTO 7080
7080 PRINT "RAMPRINT"
7090 GOTO 7100
7100 LET A=71
7110 LET B=71
7120 PRINT "RAMPRINT"
7130 GOTO 7140
7140 PRINT "RAMPRINT"
7150 GOTO 7160
7160 PRINT "RAMPRINT"
7170 GOTO 7180
7180 PRINT "RAMPRINT"
7190 GOTO 7200
7200 LET A=72
7210 LET B=72
7220 PRINT "RAMPRINT"
7230 GOTO 7240
7240 PRINT "RAMPRINT"
7250 GOTO 7260
7260 PRINT "RAMPRINT"
7270 GOTO 7280
7280 PRINT "RAMPRINT"
7290 GOTO 7300
7300 LET A=73
7310 LET B=73
7320 PRINT "RAMPRINT"
7330 GOTO 7340
7340 PRINT "RAMPRINT"
7350 GOTO 7360
7360 PRINT "RAMPRINT"
7370 GOTO 7380
7380 PRINT "RAMPRINT"
7390 GOTO 7400
7400 LET A=74
7410 LET B=74
7420 PRINT "RAMPRINT"
7430 GOTO 7440
7440 PRINT "RAMPRINT"
7450 GOTO 7460
7460 PRINT "RAMPRINT"
7470 GOTO 7480
7480 PRINT "RAMPRINT"
7490 GOTO 7500
7500 LET A=75
7510 LET B=75
7520 PRINT "RAMPRINT"
7530 GOTO 7540
7540 PRINT "RAMPRINT"
7550 GOTO 7560
7560 PRINT "RAMPRINT"
7570 GOTO 7580
7580 PRINT "RAMPRINT"
7590 GOTO 7600
7600 LET A=76
7610 LET B=76
7620 PRINT "RAMPRINT"
7630 GOTO 7640
7640 PRINT "RAMPRINT"
7650 GOTO 7660
7660 PRINT "RAMPRINT"
7670 GOTO 7680
7680 PRINT "RAMPRINT"
7690 GOTO 7700
7700 LET A=77
7710 LET B=77
7720 PRINT "RAMPRINT"
7730 GOTO 7740
7740 PRINT "RAMPRINT"
7750 GOTO 7760
7760 PRINT "RAMPRINT"
7770 GOTO 7780
7780 PRINT "RAMPRINT"
7790 GOTO 7800
7800 LET A=78
7810 LET B=78
7820 PRINT "RAMPRINT"
7830 GOTO 7840
7840 PRINT "RAMPRINT"
7850 GOTO 7860
7860 PRINT "RAMPRINT"
7870 GOTO 7880
7880 PRINT "RAMPRINT"
7890 GOTO 7900
7900 LET A=79
7910 LET B=79
7920 PRINT "RAMPRINT"
7930 GOTO 7940
7940 PRINT "RAMPRINT"
7950 GOTO 7960
7960 PRINT "RAMPRINT"
7970 GOTO 7980
7980 PRINT "RAMPRINT"
7990 GOTO 8000
8000 LET A=80
8010 LET B=80
8020 PRINT "RAMPRINT"
8030 GOTO 8040
8040 PRINT "RAMPRINT"
8050 GOTO 8060
8060 PRINT "RAMPRINT"
8070 GOTO 8080
8080 PRINT "RAMPRINT"
8090 GOTO 8100
8100 LET A=81
8110 LET B=81
8120 PRINT "RAMPRINT"
8130 GOTO 8140
8140 PRINT "RAMPRINT"
8150 GOTO 8160
8160 PRINT "RAMPRINT"
8170 GOTO 8180
8180 PRINT "RAMPRINT"
8190 GOTO 8200
8200 LET A=82
8210 LET B=82
8220 PRINT "RAMPRINT"
8230 GOTO 8240
8240 PRINT "RAMPRINT"
8250 GOTO 8260
8260 PRINT "RAMPRINT"
8270 GOTO 8280
8280 PRINT "RAMPRINT"
8290 GOTO 8300
8300 LET A=83
8310 LET B=83
8320 PRINT "RAMPRINT"
8330 GOTO 8340
8340 PRINT "RAMPRINT"
8350 GOTO 8360
8360 PRINT "RAMPRINT"
8370 GOTO 8380
8380 PRINT "RAMPRINT"
8390 GOTO 8400
8400 LET A=84
8410 LET B=84
8420 PRINT "RAMPRINT"
8430 GOTO 8440
8440 PRINT "RAMPRINT"
8450 GOTO 8460
8460 PRINT "RAMPRINT"
8470 GOTO 8480
8480 PRINT "RAMPRINT"
8490 GOTO 8500
8500 LET A=85
8510 LET B=85
8520 PRINT "RAMPRINT"
8530 GOTO 8540
8540 PRINT "RAMPRINT"
8550 GOTO 8560
8560 PRINT "RAMPRINT"
8570 GOTO 8580
8580 PRINT "RAMPRINT"
8590 GOTO 8600
8600 LET A=86
8610 LET B=86
8620 PRINT "RAMPRINT"
8630 GOTO 8640
8640 PRINT "RAMPRINT"
8650 GOTO 8660
8660 PRINT "RAMPRINT"
8670 GOTO 8680
8680 PRINT "RAMPRINT"
8690 GOTO 8700
8700 LET A=87
8710 LET B=87
8720 PRINT "RAMPRINT"
8730 GOTO 8740
8740 PRINT "RAMPRINT"
8750 GOTO 8760
8760 PRINT "RAMPRINT"
8770 GOTO 8780
8780 PRINT "RAMPRINT"
8790 GOTO 8800
8800 LET A=88
8810 LET B=88
8820 PRINT "RAMPRINT"
8830 GOTO 8840
8840 PRINT "RAMPRINT"
8850 GOTO 8860
8860 PRINT "RAMPRINT"
8870 GOTO 8880
8880 PRINT "RAMPRINT"
8890 GOTO 8900
8900 LET A=89
8910 LET B=89
8920 PRINT "RAMPRINT"
8930 GOTO 8940
8940 PRINT "RAMPRINT"
8950 GOTO 8960
8960 PRINT "RAMPRINT"
8970 GOTO 8980
8980 PRINT "RAMPRINT"
8990 GOTO 9000
9000 LET A=90
9010 LET B=90
9020 PRINT "RAMPRINT"
9030 GOTO 9040
9040 PRINT "RAMPRINT"
9050 GOTO 9060
9060 PRINT "RAMPRINT"
9070 GOTO 9080
9080 PRINT "RAMPRINT"
9090 GOTO 9100
9100 LET A=91
9110 LET B=91
9120 PRINT "RAMPRINT"
9130 GOTO 9140
9140 PRINT "RAMPRINT"
9150 GOTO 9160
9160 PRINT "RAMPRINT"
9170 GOTO 9180
9180 PRINT "RAMPRINT"
9190 GOTO 9200
9200 LET A=92
9210 LET B=92
9220 PRINT "RAMPRINT"
9230 GOTO 9240
9240 PRINT "RAMPRINT"
9250 GOTO 9260
9260 PRINT "RAMPRINT"
9270 GOTO 9280
9280 PRINT "RAMPRINT"
9290 GOTO 9300
9300 LET A=93
9310 LET B=93
9320 PRINT "RAMPRINT"
9330 GOTO 9340
9340 PRINT "RAMPRINT"
9350 GOTO 9360
9360 PRINT "RAMPRINT"
9370 GOTO 9380
9380 PRINT "RAMPRINT"
9390 GOTO 9400
9400 LET A=94
9410 LET B=94
9420 PRINT "RAMPRINT"
9430 GOTO 9440
9440 PRINT "RAMPRINT"
9450 GOTO 9460
9460 PRINT "RAMPRINT"
9470 GOTO 9480
9480 PRINT "RAMPRINT"
9490 GOTO 9500
9500 LET A=95
9510 LET B=95
9520 PRINT "RAMPRINT"
9530 GOTO 9540
9540 PRINT "RAMPRINT"
9550 GOTO 9560
9560 PRINT "RAMPRINT"
9570 GOTO 9580
9580 PRINT "RAMPRINT"
9590 GOTO 9600
9600 LET A=96
9610 LET B=96
9620 PRINT "RAMPRINT"
9630 GOTO 9640
9640 PRINT "RAMPRINT"
9650 GOTO 9660
9660 PRINT "RAMPRINT"
9670 GOTO 9680
9680 PRINT "RAMPRINT"
9690 GOTO 9700
9700 LET A=97
9710 LET B=97
9720 PRINT "RAMPRINT"
9730 GOTO 9740
9740 PRINT "RAMPRINT"
9750 GOTO 9760
9760 PRINT "RAMPRINT"
9770 GOTO 9780
9780 PRINT "RAMPRINT"
9790 GOTO 9800
9800 LET A=98
9810 LET B=98
9820 PRINT "RAMPRINT"
9830 GOTO 9840
9840 PRINT "RAMPRINT"
9850 GOTO 9860
9860 PRINT "RAMPRINT"
9870 GOTO 9880
9880 PRINT "RAMPRINT"
9890 GOTO 9900
9900 LET A=99
9910 LET B=99
9920 PRINT "RAMPRINT"
9930 GOTO 9940
9940 PRINT "RAMPRINT"
9950 GOTO 9960
9960 PRINT "RAMPRINT"
9970 GOTO 9980
9980 PRINT "RAMPRINT"
9990 GOTO 10000
10000 LET A=100
10010 LET B=100
10020 PRINT "RAMPRINT"
10030 GOTO 10040
10040 PRINT "RAMPRINT"
10050 GOTO 10060
10060 PRINT "RAMPRINT"
10070 GOTO 10080
10080 PRINT "RAMPRINT"
10090 GOTO 10100
10100 LET A=101
10110 LET B=101
10120 PRINT "RAMPRINT"
10130 GOTO 10140
10140 PRINT "RAMPRINT"
10150 GOTO 10160
10160 PRINT "RAMPRINT"
10170 GOTO 10180
10180 PRINT "RAMPRINT"
10190 GOTO 10200
10200 LET A=102
10210 LET B=102
10220 PRINT "RAMPRINT"
10230 GOTO 10240
10240 PRINT "RAMPRINT"
10250 GOTO 10260
10260 PRINT "RAMPRINT"
10270 GOTO 10280
10280 PRINT "RAMPRINT"
10290 GOTO 10300
10300 LET A=103
10310 LET B=103
10320 PRINT "RAMPRINT"
10330 GOTO 10340
10340 PRINT "RAMPRINT"
10350 GOTO 10360
10360 PRINT "RAMPRINT"
10370 GOTO 10380
10380 PRINT "RAMPRINT"
10390 GOTO 10400
10400 LET A=104
10410 LET B=104
10420 PRINT "RAMPRINT"
10430 GOTO 10440
10440 PRINT "RAMPRINT"
10450 GOTO 10460
10460 PRINT "RAMPRINT"
10470 GOTO 10480
10480 PRINT "RAMPRINT"
10490 GOTO 10500
10500 LET A=105
10510 LET B=105
10520 PRINT "RAMPRINT"
10530 GOTO 10540
10540 PRINT "RAMPRINT"
10550 GOTO 10560
10560 PRINT "RAMPRINT"
10570 GOTO 10580
10580 PRINT "RAMPRINT"
10590 GOTO 10600
10600 LET A=106
10610 LET B=106
10620 PRINT "RAMPRINT"
10630 GOTO 10640
10640 PRINT "RAMPRINT"
10650 GOTO 10660
10660 PRINT "RAMPRINT"
10670 GOTO 10680
10680 PRINT "RAMPRINT"
10690 GOTO 10700
10700 LET A=107
10710 LET B=107
10720 PRINT "RAMPRINT"
10730 GOTO 10740
10740 PRINT "RAMPRINT"
10750 GOTO 10760
10760 PRINT "RAMPRINT"
10770 GOTO 10780
10780 PRINT "RAMPRINT"
10790 GOTO 10800
10800 LET A=108
10810 LET B=108
10820 PRINT "RAMPRINT"
10830 GOTO 10840
10840 PRINT "RAMPRINT"
10850 GOTO 10860
10860 PRINT "RAMPRINT"
10870 GOTO 10880
10880 PRINT "RAMPRINT"
10890 GOTO 10900
10900 LET A=109
10910 LET B=109
10920 PRINT "RAMPRINT"
10930 GOTO 10940
10940 PRINT "RAMPRINT"
10950 GOTO 10960
10960 PRINT "RAMPRINT"
10970 GOTO 10980
10980 PRINT "RAMPRINT"
10990 GOTO 11000
11000 LET A=110
1101
```

# DEMON FROM THE DARKSIDE

Don't be put off by the cassette insert artwork, which is pretty grisly to say the least. **Demon from the Darkside** is a snappy, no nonsense little adventure which was put together using **The Quill** and **The Illustrator**, and a fair amount of attention to detail if the information you get when you call up the vocab list is anything to go by.

You are the good wizard's apprentice, trying to hold off the demon armies of the bad wizard. To delay the shadow demons controlled by the bad guy you have to enter his (ie the villain's) hidey-hole and slay him. Simple really - you only have an army of demons to worry about, plus assorted standard adventure game problems.

One thing which irked me somewhat was the spelling - reminiscent of some of Level 9's early stuff. I mean, using advise instead of advice, and spelling things ence instead of ance. . . However, such things should not be allowed to detract from the actual game.

The graphics are decent enough, and you have the option of turning them off if you like. I especially liked the way objects also had accompanying graphics, so when you call for an inventory you get pictures of what you've got as well as the list in words.

## FACTS BOX

*Quite an easy adventure but still good fun. Some of the spelling is a bit dodgy though*

### DEMON FROM THE DARKSIDE

Label: Compass  
36 Globe Place, Norwich, Norfolk  
Author: J. Lemon  
Price: £2.50  
Memory: 48K/128K

Reviewer: *Gams Rook*



I haven't got very far yet - the perennial cry of the adventure reviewer not provided with a solution - but I have been able to pat myself on the back a couple of times for solving some of the problems which are quite tricky.

The Sid mentioned on the vocab list, by the way, isn't the mysterious Sid of the British Gas shares advert (unfortunately - I would have loved to have strangled him, I'm so sick of hearing his name), but a white rat who might help you once given the gift of new life.

One very useful feature of the game is a *Ramsave* option,

It must be my lucky day - another independent adventure which displays a heap of wit and intelligence! And great graphics, too. . .

**Paradise Connection** is another **Quilled** and **Illustrated** adventure, this time from a company called Birdseed Software.

The plot is original and highly amusing: America faces a financial crisis so bad even the President has had to try to think about it. The FBI and the CIA, even with massive amounts spent on market research, the cassette label informs you, have failed to find out where all the dollars are disappearing to. Anyway, to cut a long introduction short, you, Kid Capello, the FBI's worst agent (a sort of Washington version of

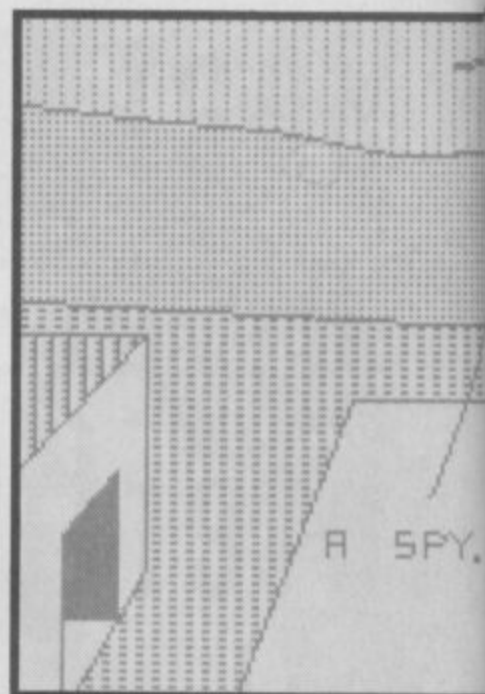

# PARADISE

Inspector Clouseau, no doubt) have been sent to the little town of Brandis Reef, somewhere in Latin America, to find out who's nicking the President's dollars and just how they're doing it.

The graphics are excellent - cartoon-like drawings of people, you in a trench coat and trilby hat looking like something out of an old 'B' movie. So far, I've been to about 20 locations, but I haven't found much to do

yet. I suspect I should be talking to all the people I meet, but right at the moment I'm more interested in sight-seeing.

I've avoided getting killed in quicksand by the simple expedient of taking notice of the warning sign, I've been swept off to a desert island by a freak wave, and I've been humiliated after trying to kill an arab who seems to spend his time dancing on the table-top in his

which allows you to dump your present location to memory without having to bother fiddling about with tape recorders. Of course, if you want to turn your Spectrum off but *Save* the game, you'll need to fall back on the old fashioned cassette again.

**Demon** is good, though perhaps a little simple. After all, I was surprised to get as far as I have so quickly. . . ■

# ORAN

**D**ual Dimension Software's **Quest for the Golden Orange Peel** is another of those adventures where you have to find the magical mystical item - orange peel, ring, C5 etc - and bring it back.

# ADVENTURE

This program left me in something of a quandry, because **Adventure** is,

## FACTS BOX

*Affectionate homage to Advent, the first ever adventure game. If you know the plot it's not for you*

### ADVENTURE

Label: Adventure Software  
(soon to be released on the Players label)  
Price: £1.99  
Memory: 48K/128K

Reviewer: *Gams Rook*



unashamedly, a copy of the first ever adventure game.

For those of you who may not know your computer game history, back in the mists of time (the early 1970s) two computer geniusses called Don Woods and Willy Crowther - Americans both - wrote a game called **ADVENT**. They called it that because at the time, computer files could only have names of up to six letters, and they had to be in caps. **ADVENT**, believe it or not, is short for adventure.

Since then, numerous people have written their own version of the game, some of them commercial products. This is possible because the program was public domain - ie nobody claimed copyright on it. **Adventure** is yet another version.

That means that, to the seasoned adventure, the plot is as familiar as the Lord's Prayer to a born again Christian. You have to collect the treasures,

take them back to the hut where you start. The objective is to collect all the treasures there are in the game and so score maximum points.

I'm assuming that, since this is a copy of **ADVENT**, the plot continues to be basically the same - I haven't had the time to

and green meadows that slope gently away westwards.

What now? N

You are on a north/south road crossing a plain littered with volcanic debris. The land rises to the north. North-east there is a mountainous volcano. To the north-west you can see the stark outline of a desolate moor. To the west there are lowlands.

What now? W

You are upon the floor of a wide valley. Spiky green reeds poke through the grass, and from far away you can hear the faint boom of a bittern.



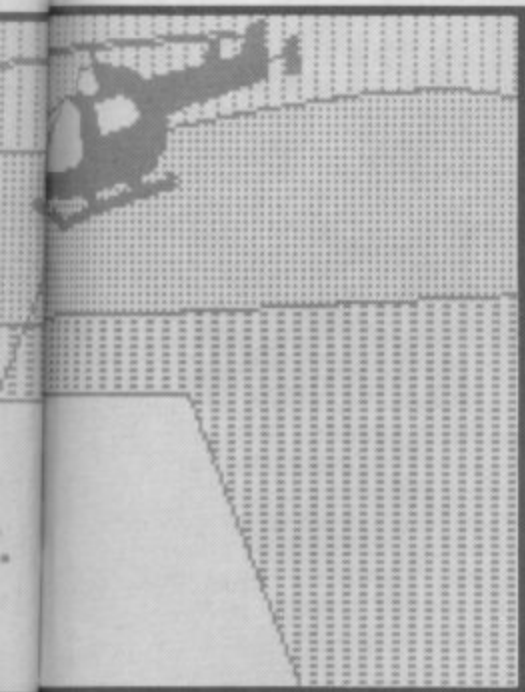

## FACTS BOX

*Highly imaginative plot. It's the political conspiracy CIA/FBE involved in Latin American scenario. Entertaining too*

## PARADISE CONNECTION

Label: Birdseed  
Springfield, 180A Purlpit, Atworth,  
Melksham, Wilts

Price: £3.99  
Memory: 48K<sup>1</sup>/128K

Reviewer: *Gams Look*



# CONNECTION

seedy night club. 'What a plonker - I'm no Rambo' sneered the screen before telling me that I'd been killed by said Arab.

My only objection to the program is that it's possible to see it as just the teeniest bit racist. Personally, I think that's rather objectionable - but it doesn't detract too much from the rest of the game.

So long as you don't mind the

rather cardboard stereotype funny foreigners, a good game that should offer quite a few decent puzzles.

It's certainly good to see someone trying to create an original plot, rather than copying everyone else.

It just proves that, with tools like the Quill, it's the ideas that are important - and anybody can have good ideas, regardless of programming skill ■

# ORANGE PEEL

Why, you're never told, and in this case you are unlikely to care very much after a few moves either.

You begin the game outside a mysterious grey temple that looks from the rather crude illustration like it was designed

play through the entire game, nor have I seen a solution. Indeed, there would be nothing wrong with that if it were the same game - it's very challenging, and everybody who claims to be an adventurer should have had a go at it at least once in their lives. But it has also been done so many times: I really don't know if we need another version of it.

Having said that, Adventure Software's version is very attractive the screens are well laid out, the choice of colours is good and makes the text easy to read, and everything seems to be programmed correctly.

Which means that if you haven't got a copy of **ADVENT**, then I would recommend this one for you - it's as good as any other.

If you have already got a copy, or played it on a mainframe, then I wouldn't bother ■

by the man who thought of lego, only he'd only invented one type of brick and they were all grey. Go North and you're stuck in the temple and, as you need some items from outside I'd go South if I were you.

South you find an uninteresting town where everybody sunbathes all day (don't blame me, that's what it says on the screen) and a very yellow desert. I mean yellow - like so bright it hurts the eyes.

Pick up the objects you find on the way and then get back to the temple. Inside you'll find that the place seems to be scattered with pornography, including 'tapestries' and copies of *Playboy*. Don't bother with the snakes - they kill you (mainly with more bad spelling: one of them gives you a head butt. Try peeling the padding off the cell and crawling through the hole you'll find.

Personally, I'd prefer less of the smutty innuendos and bad in-jokes (so bad they're actually out-jokes) about adventures and computer personalities, and definitely less of the pictures - like none at all. They don't add anything really just a waste of money.

What I would have liked more of? Well, how about more use

# DON'T PANIC PANIC NOW

**D**on't Panic - Panic Now! (which from now on I'm going to call **DPPN**) is an example of a genre of adventure game made famous by the sainted Fergus McNeil of Delta 4: that of the spoof or parody.

Indeed, one Fungus MacNaill makes an appearance in **DPPN**, rabbiting on about Delta 4.

Unfortunately, Dented Designs aren't half as good at it as Delta 4. In **DPPN**, as any fan of the four books in the *Hitch-Hiker* trilogy may have guessed by now, the words being parodied are those of Douglas Adams (and presumably the Infocom adventure game based on the books as well).

The whole thing has been put together with **The Quill** and **Illustrator**, and the graphics are typically angular, although

## FACTS BOX

*A miss. Tired plot, unimaginative writing and poor vocabulary. Nice title, shame about the game*

## QUEST FOR THE GOLDEN ORANGE PEEL

Label: Dual Dimension  
Cedarwood, Darkes Lane, Potters Bar, Herts

Price: £3.99  
Memory: 48K/128K

Reviewer: *Gams Look*



Ivory stand where the orange peel has lain for many centuries before it was removed. Exits: east, west. You can see - An old sign.

■ **INFO**  
You are carrying - The Concise Oxford Gibberish Dictionary  
A chipmunk

■ **HELP**  
What do you mean? The chipmunk grunts.

■ **HELP**  
Follow instructions on cassette inlay to get a free clue sheet.

of the dictionary for a start - and not the dictionary of gibberish you find in the game either. And how about a bit more imagination as well. **Orange Peel** is really little more than a tired old plot barely tacked together with some tired old sudden-death situations ■

## ADVENTURE

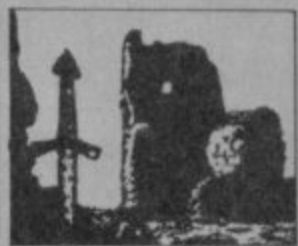

## REVIEW

## FACTS BOX

*Huge spoof - three full Loads - based loosely on the Hitch-Hiker's Guide. The snag is it's not all that funny*

## DON'T PANIC PANIC NOW

Label: Dented Designs  
Memory: 48K/128K

Reviewer: *Gams Look*



pretty good nonetheless. The game is divided into three parts, and you have to solve each preceding part to get into the next one. Why designers think this is a good idea I don't know - I think it's far more likely to put people off buying the games. Why shouldn't you solve Part 2 before Part 1 anyway?

You are Arfur Bent, your house is about to be demolished by the big yellow bulldozers, your friend Ford Popular (or is it Consul?) keeps wittering on about the end of the world... yes, you've heard it all before.

But wait! That means that the answers to the problems are the same, right? Well, no, actually. Try lying down in front of these bulldozers, and you get run over.

Unfortunately, there isn't enough originality to grab your interest.

That may seem like a strange thing to say of a parody adventure, but actually it's not enough just to twist a few ideas and make a few bad jokes. You have to work very hard at pastiches to make them funny, otherwise they get very dull, very quickly.

I think that Dented Designs would have been far better advised if it had written an entirely new plot around the same basic problems. There's nothing wrong with the actual puzzles themselves. They work fine.

I can't really recommend **Don't Panic - Panic Now**, unless you have a long wet Saturday to fill. There's plenty of quantity, but no real meat ■

# CITY

In **City Clicker** you combat the forces of urban terrorism (as represented by a very dodgy racial stereotype Sprite in the shape of an Arab ie, it's got one of those cloth things over its head) and try to prevent the houses of Parliament being destroyed by a bomb.

Not an objective I found it very easy to identify with.

Even more difficult to assimilate is the fact that **City Slicker** is, superficially, yet another **Manic Miner** game.

In fact, my first reaction on seeing it was of horror. I thought games like this had been relegated to the budget ranks long ago.

It isn't that simple, however. **City Slicker** is by the people who brought you **Technician Ted** which got mixed reviews but sold in zillions mainly because what the reviews hadn't realised was that whilst

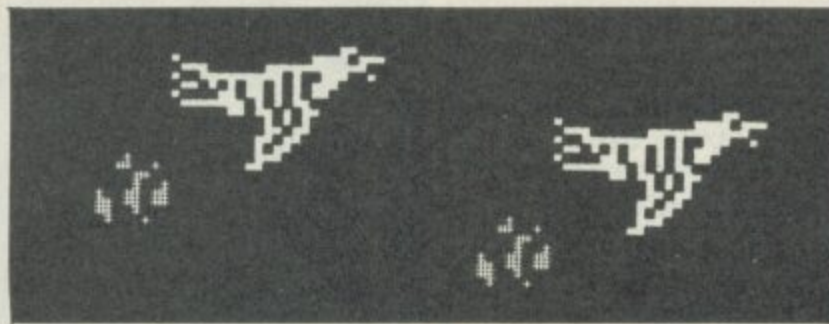

# SLICKER

the game looked dull, it had a lot of clever puzzles, some of them fiendishly difficult.

**City Slicker** is pretty much the same. Its failings are similar and it might easily be dismissed but when you come to play it – well it's quite good fun. A sort of **Jet Set Willy** meets **Spellbound** in that your time is equally divided between working out how to jump over obstacles 'leap over the penguin when it nearly reaches the cherry then quickly drop down the whole screen whilst turning around. . . ' and

## FACTS BOX

*Jet Set Willy meets Spellbound well-worn game ideas that shouldn't be entertaining yet somehow are*

CITY SLICKER

Label: Hewson

Author: David Cooke and Steve Marsden

Price: £8.95

Memory: 48K/128K

Joystick: various

Reviewer: *Gordon Taylor*



working out what object you can pick up does what 'having got the herring I should now be able to open the box and get the lathe to make the key to the door. . . '

The plot is all about assembling a bomb deactivator device. The various unlikely parts of the device are strewn around London as it would look if it comprised 50 caverns.

Between some areas you can take the tube and thus rest your weary feet from all that

## ARCADE



intensive jumping.

Then there is this terrorist whose arrival is indicated by weird noises from your Spectrum. In fact there are dozens of odd little things, that redeem this game no end.

The graphics are well – how can I put this – they look like almost every single one of the **Jet Set** gang. There are telephones, cute little guards (beefeaters actually), 100 ton weights, platforms, sudden gaps, indescribable blobby things in fact the complete 'how to make a **Jet Set Willy** game' kit of sprites. They don't flicker too much, though there is the occasional attribute clash.

I quite liked the birds in Trafalgar Square whose air to ground bombings must be avoided on pain of death and was impressed by the poor herberts – people – you can pick up and treat as an 'object' dropping them from great heights on to nasty objects for example. The main virtue of the game is its puzzles, however.

In the cheat sheet handed out to reviewers, the solution to getting the first part of the deactivator ran to two pages.

I can't say this sort of thing fills me with much joy but for some it'll be game of the year ■

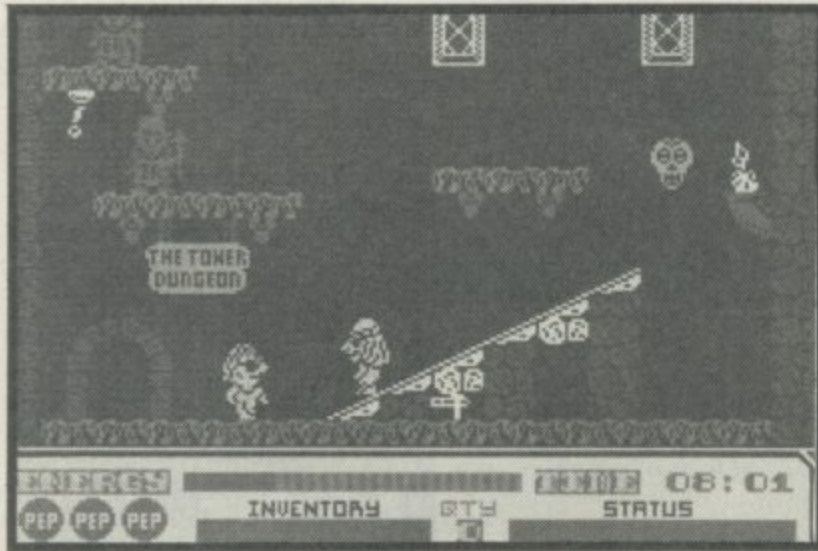

Oh No! Why did I get this? Doctor What! I mean there is a title that says "this is going to be a fun filled game that isn't the slightest bit funny".

I think it's supposed to be a spoof of Dr Who (he said pointlessly). A spoof if you think that Trydis rather than Tardis is funny. Doubtless CRL will ship a few before the BBC's lawyers start to send them nasty letters.

**Dr What** is a very basic **Spellbound**-style game. It has object that you pick up, store and use in various unlikely ways. You, the Doctor, are a large sprite, movement looks not so much jerky, more as if rigor mortice has set in.

The plot? Well there are these four Doctors (yes, four) called . . . What, When, Where and Why? Why? is the question I keep asking myself. Each Doctor has his (?) own tremendously amusing problem, although finding a key to the Trydis (usually just lying around) means you can zip off

# DR WHAT

somewhere else.

To be generous there was one reasonably Okish sort of problem I came across – a cliff face to be climbed where the shape of particular rocks gave

you a clue to a route up, get it wrong and you fall.

Mostly, however, the game is spent jumping up on tables and collecting objects that don't look like what the status screen

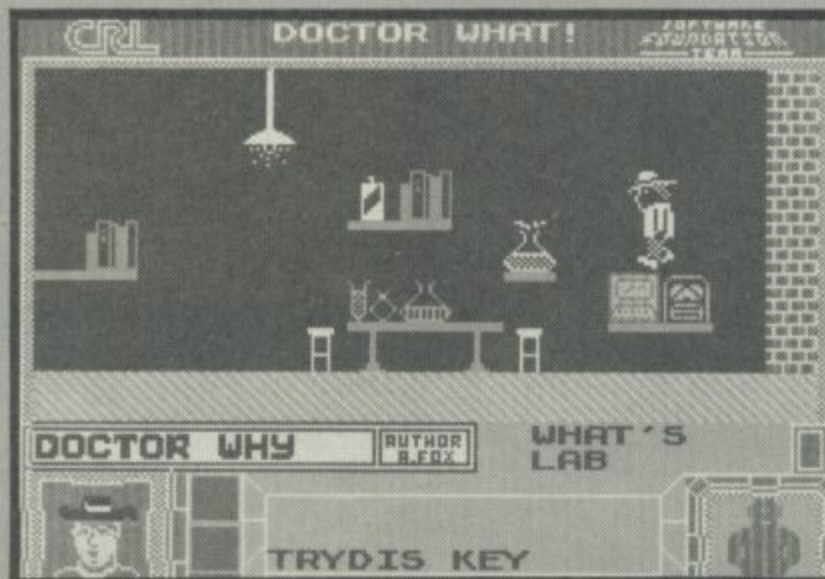

## FACTS BOX

*Tired variation on the Spellbound formula. Tries very hard to be funny but fails miserably. Better as budget*

DOCTOR WHAT!

Label: CRL

Author: Software Foundation

Price: £7.95

Memory: 48K/128K

Joysticks: Cursor etc

Reviewer: *Jim Douglas*

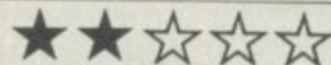

says they are. If there is relatively little attribute clash it's only because of the lack of detail in most of the graphics.

Surely it should have been a budget offering – it is certainly inferior to **Spellbound** and yet sells for £7.95. Maybe CRL are thinking of those legal costs ■

# SUPER SOCCER

## THE GAME OF THE SEASON

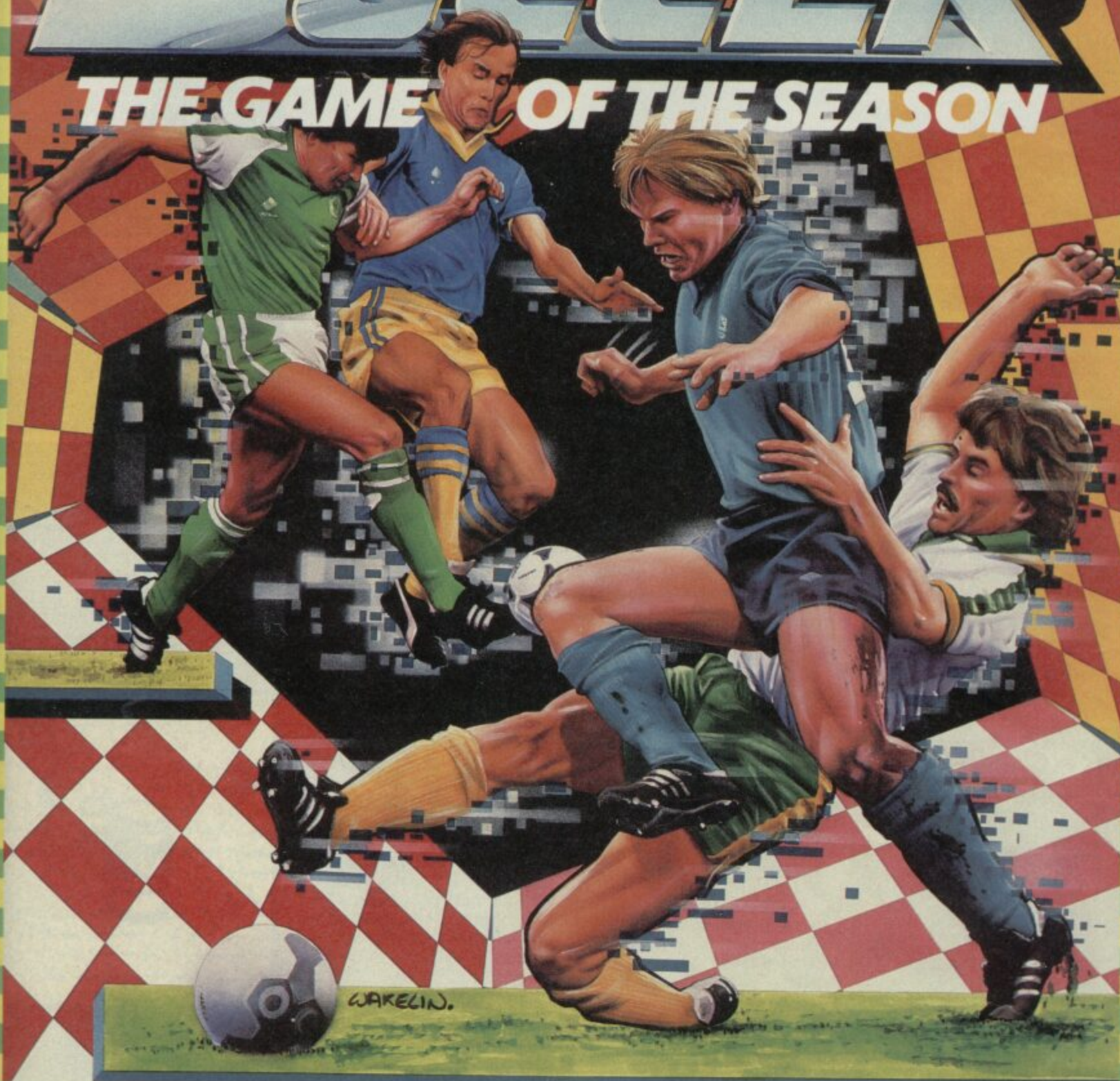

We think Super Soccer is the best computer soccer simulator yet. Be Maradona on screen. You can dribble past opponents, slide tackle, make crosses, even attempt diving headers. But what makes this game outstanding in its own field is the control you can exercise over the ball. No other game allows you to control the strength of your sharp shooting and ball passing like Super Soccer does. What's more, when taking free kicks you can organise the whole team with the "full team positional play" feature.

This is a 1 or 2 player game and there's an optional extra which allows up to 8 separate players to participate in a tournament competition.

So get on the ball in the game of the season.

**SPECTRUM**  
**£7.95**

# JUDGE DREDD



**J**udge Dredd, the computer game. Coming soon from Melbourne House. Does it do any sort of justice? You play Dredd, as impersonated by a fairly convincing sprite.

The game plot isn't at all bad. Thankfully Melbourne hasn't tried to invent some sort of ridiculous special plot that enables them to include 50 different bouncing aliens.

The game is all about crime. Your task is to stop it – to stop every sort of crime from littering, to comic dealing (kids get addicted to them), to murder. Crime is a constant feature of Megacity One.

In Stage 1 of the game you have a map, a plan view of Megacity with icons representing the various kinds of crime scattered about as they happen. And you must use your judgement to decide what

crime to go for first and what sequence of crime fighting will be most economical of time.

Time is of the essence because crime is breaking out all over the place and if more than eight misdemeanours are happening simultaneously you get fired. For a Judge that's a fate worse than death.

Having selected a crime, the scene changes to a **Dan Dare**, esque representation of City Blocks, Megacity One and the Under City.

Most crimes occur high in the blocks but you'll need to cross the Megacity walkways and may sometimes be forced to venture down into the Under City where danger lurks in every crumbling corner. Dredd has to run around leaping between the walkways or leaping into lifts seeking out the crime and arresting or wasting the

participants.

The representation of Megacity is reasonable but definitely less shabby than the real thing – it all looks so clean. I like the views of distant grim tower blocks though.

Dredd may have to deal with

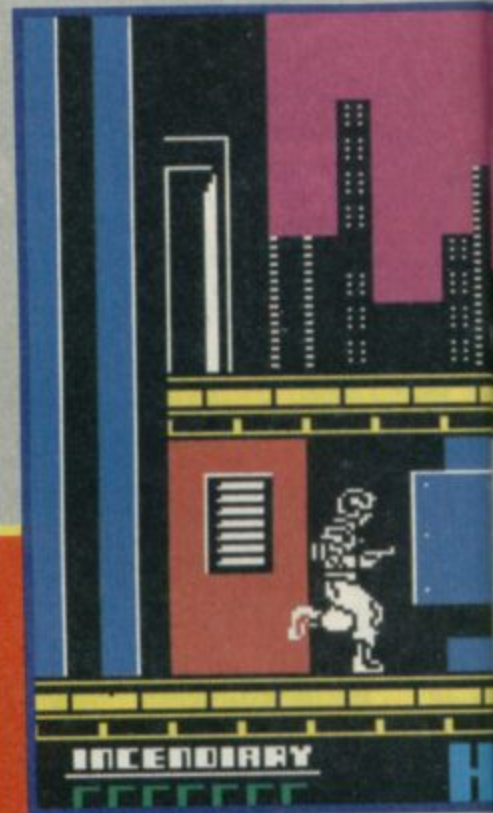
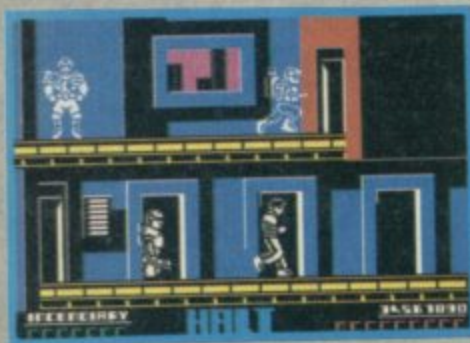

**M**aybe it doesn't matter all that much when a terrible Hollywood Blockbuster epic is turned into a terrible computer game.

But now there's a different and far more disturbing trend – the licencing of comic book characters.

In particular from *2000 AD* a comic much beloved by many of us **SU** hacks.

It's recently been looted of *Rogue Trooper* (gasp) and (gasp, gasp) *Judge Dredd*. Having spent many hours and more pounds rummaging through *Forbidden Planet* for previously unseen editions of the magazine we were concerned what kind of abominations would be produced?

We take a detailed look at Melbourne house's *Judge Dredd* project, review *Rogue Trooper* from Piranha and try to decide if anything like justic has been done ■



state of the art graphically is certainly in the first division. Big sprites which trot along (it has to be said that *Rogue's* walk is not very macho – more carefree



# ROGUE

**I**t says something for *2000AD* that it has been the source of so many ideas for computer games.

Now Piranha has lifted out *Rogue Trooper* to fight on the Spectrum.

*Rogue Trooper*, a sort of mutant Rambo of the future, battles alone against a relentless foe. His mission – to destroy a traitor who betrayed *Rogue's* GI buddies. The buddies are not actually dead. Their personalities are stored on microchips and in destroying the traitor *Rogue* will win their release. As you can see there is going to be a lot of serious killing in this game.

The game look visually very like *Commando* presented as a 3D scrolling game, big sprites and a true sense of perspective. This is good.

The gameplay is fairly complex – aside from

destroying very many things, there are little icons representing the chipped buddies who offer advice ('kill, kill, kill', mostly) and things like stamina levels to be maintained etc. This is also good.

There are eight tapes to be collected – video recordings which together provide the evidence necessary to convict the traitor – and I found four of them on my second attempt at the game. This, I would have thought, is bad.

The game, though maybe not

**S**econd only to *Dredd* in *2000AD* mythology, *Trooper* is another lone man dispensing his own kind of justice in an inhospitable and barren landscape.

His objective has always been vengeance – to find the traitor who turned his buddies into biochips and perhaps even return them to life.

In Nu-Earth where everybody else is crazed, *Rogue Trooper* is the only one still sane – and sometimes even that is in doubt ■

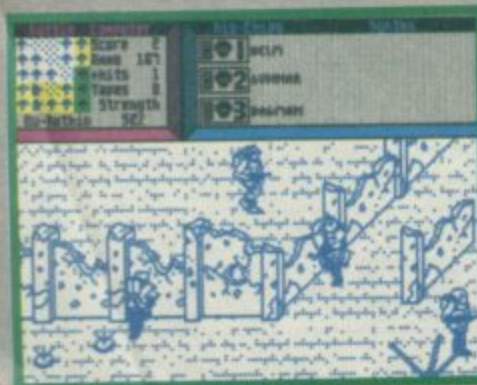

# EDD

other problems on his way to a crime. These are in keeping with the comic so full marks for authenticity. There are the Garbage Grinders into which it is a bad idea to fall. Sudden patches of ice send Dredd into an uncontrollable skid.

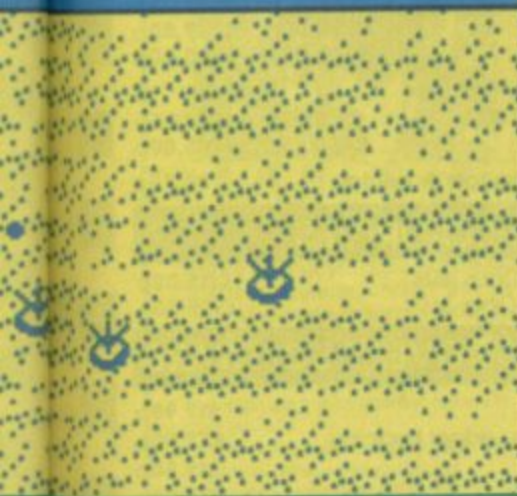

really) smoothly and quite detailed backgrounds. The restriction to two-colour gives no attribute clash but makes things a little difficult to see on some screens – particularly yellow on white is a bit distracting.

Although clearly a large part of the point of the game is kill and not being killed, the speed at which everything happens is very restricted. Because of the large number of big sprites moving about at the same time it's all a bit slow and this

**"You're next, punk!"** What is it about Dredd that makes him probably the most powerful comic book character of the last ten years? In America you can probably take a degree in the subject.

Dredd is a different sort of superhero, he does some good in a world where because of claustrophobic tower blocks and high unemployment doing bad is understandable.

But for Dredd life in the slums of Megacity One admits no fudging of black and white. Judge Dredd's strength is that he is so certain of everything and so vigorous in his upholding of his sense of right. This frequently results in instant execution on the street.

Put simply, Judge Dredd is a very right-wing sort of hero, with a sense of right and wrong not dissimilar to Charles Bronson in *Death Wish*. Judge Dredd would make a pretty good member of some parts of the conservative party, in fact ■

Conveyor belts convey him – usually into something bad. . .

In other places parts of the platforms and walkways between the city blocks may collapse and then there are the patches of alien seed that will grab hold of your boots and slow you up.

More animated obstacles include Maintenance Robots which get in the way, Satellats and Robo Hounds which will take pot shots at you if they can. Under City dwellers and Perps are also out for blood but are marginally (maybe) less dangerous. The remaining problem is passers by – innocent bystanders get in the way a lot and basically it's not a good idea to kill them although you don't lose serious points for it and actually it's quite a lot of fun blasting them.

Which brings us to Dredd's own special ways of dispensing justice.

You have three attack options. You can elect to fire a warning shot – a speech bubble saying either 'Halt' or 'Blam'

will appear. 'Halt' is OK but 'Blam' is not a very Dreddish word. If Dredd is close to another person the *Fire* button press is interpreted as a punch – it does as much damage as firing but looks funnier. The battle between Dredd and an escaping Perp is sometimes highly fraught – each successful hit only reduces the Perps stamina level – some Perps have a stamina level greater than yours – and they will

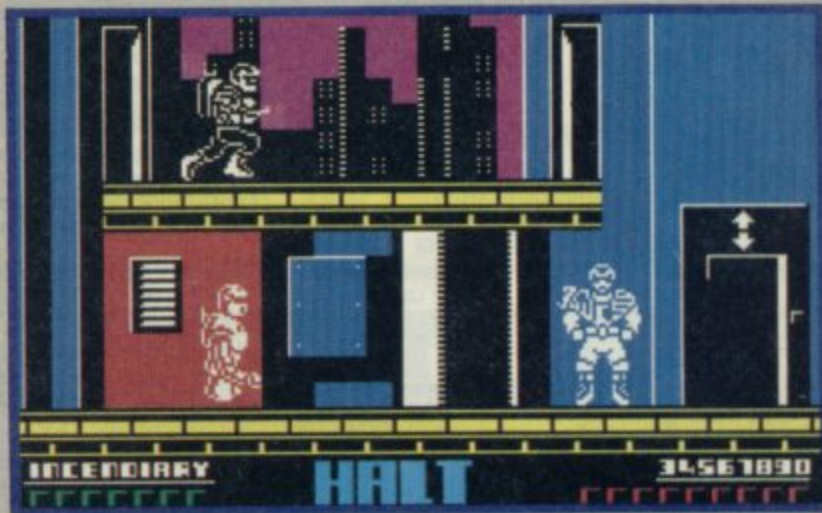

## ARCADE



certainly fire back. This is one of the really good things about Dredd – the fights are genuine fights.

Graphically I rate the game (a pre-production version I should stress) as pretty close to *Dan Dare* in style.

As a recreation of the style of the comic book it's really not bad at all though – in the end it comes down to a lot of continuous tension and gung-ho shoot-em-outs (not ups).

It's retained a certain portion of the black humour to be found in the original comic book and for that let's give thanks. We haven't stuck any sort of rating on it because the Spectrum version wasn't close enough to completion but it's looking very promising ■

# TROOPER

## FACTS BOX

*Nice to look at but just not fast enough to crack it as the sort of arcade action game it is supposed to be*

### ROGUE TROOPER

Label: Piranha  
Author: Design Design  
Price: £9.95  
Memory: 48K/128K  
Joysticks: various

Reviewer: Graham Taylor



detracts seriously from the challenge of the game. It is comparatively difficult to be caught unawares and your fire

button is hardly likely to suffer damage when your bullets stroll nonchalantly across the screen.

The game is large (100+ screens) and there is some variety to the landscapes – mixed areas of desert, barbed wire and burnt-out ruins. The latter are more exciting since there is an opportunity to shoot through holes in the walls (tricky programming stuff that) and use corners as cover. Things almost get exciting.

Whilst shots from assorted enemies are relatively ineffective – you need to be hit a lot of times before it matters much – treading on a mine is instant death. This would be a source of potential tension in the game were it not for the fact that it is quite easy to avoid them. The only time I died from a mine was when moving from one screen to the other.

The problem with *Rogue Trooper* is that it has the wrong plot for this style of game. The slick big graphics cause the speed of movement to be restricted and that means it can't succeed as a high-action blast 'em game.

Conversely there isn't really enough in it to turn it into a 'find the objects and figure out what to do with them' affair.

I think most people will find it visually impressive, but slow, unexciting and all too easy ■

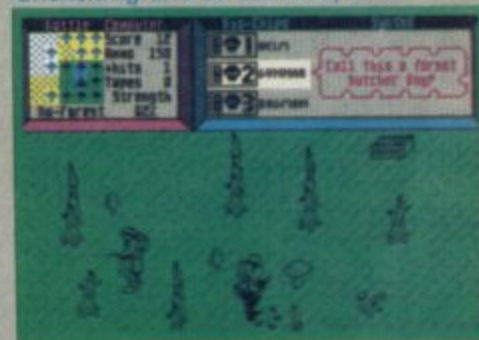

### EUROELECTRONICS ZXL PRINT III CENTRONICS-RS232 PRINTER INTERFACE

Enables your Spectrum 16k, 48k, Spectrum+ or 128k (in 48k mode) to print on almost any dot matrix or daisy wheel printer with RS232 or Centronics input. Just plug in ZXL Print III and LPRINT and LLIST commands will work. COPY works without any additional software on Epson, Star, Brother, Walters, Mannesman Tally, Taxan Kaga, Canon, Shinwa, Citizen, Epson compatibles and a full colour copy on Seiksha GP700. Optional extras are available for 4 Colour screen copies on CGP115, MCP40 & 80, SCP80, and shaded screen copies for Epson compatible printers.

ZXL Print III is also compatible with INTERFACE 1, VTX 5000 modem, OPUS Discovery and BETA interfaces.

Optional extras: 4 copy screen copies £5.00. Shaded screen copies £5.00p.

- WORD PROCESSING • PLUG IN FOR LLIST, LPRINT & COPY
- PRINTS SPECTRUM GRAPHICS & UDG's • HIGH RESOLUTION SCREEN DUMPS • TWO COPY SIZES ON EPSON & COMPATIBLES
- PRINTS PRESTEL FRAMES WITH SUITABLE MODEM
- COMPATIBLE WITH MICRODRIVES & INTERFACE 1

Now available!

RGB INTERFACE  
£45.00

Interface £29.95  
Cable £8.85  
Inc VAT

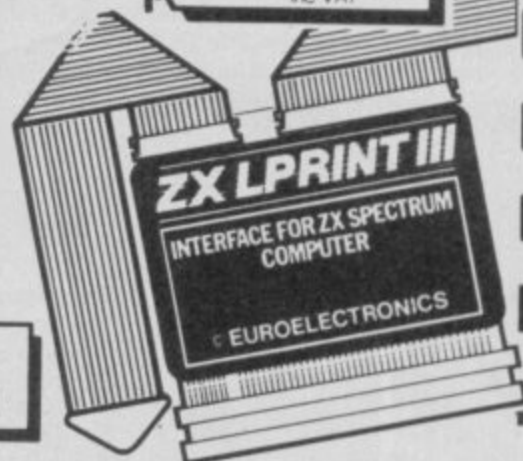

### SPECTRUM 48K BUSINESS SOFTWARE

#### BUSINESS PACK. £14.95p

This suite of programs includes Sales Day Book, Purchase Day Book and Business Bank Account. These programs are being used by over 1000 companies to produce VAT and annual accounts; the Purchase and Bank Account programs allow for analyses under 17 subheadings. The Sales programs produce statements of outstanding invoices. Both Sales and Purchase programs calculate VAT.

#### INVOICING. £15.00p

This program will print out invoices, calculates discounts and VAT. The program will calculate totals from unit prices. Up to 50 accounts with 250 outstanding invoices.

#### SALES/PURCHASE LEDGER INVOICING £25.00p

This program is for use on microdrive or Opus Disc only. The program will print an invoice using a built-in price list and post the invoice to your customer's account. Will also print price list, statements, labels, etc.

### WORDPROCESSING

#### TASWORD THREE by Tasman £16.90p

This new version of Tasword is supplied on microdrive with the following features: 128 column print out, tabs, page footers, buffered typing, page headers, full insert mode, built mail merge.

#### TASPRINT by Tasman Software £9.90p

Use this program with Tasword Three to produce 5 different fonts on a dot matrix printer.

### SPREAD SHEET

#### OMNICALC 2 by Microsphere £14.95p

This is the long-awaited micro-drive version of omnicalc complete with histograms and many other features.

### STOCK CONTROL

#### STOCK CONTROL. £10.95p

Handles 900 lines, including details of supplier. Program has full search facilities enabling you to search and update all lines from one supplier.

### DATABASES

#### MASTERFILE by Campbell Systems £14.95p

This is one of the best database programs available for the ZX Spectrum. This program has many uses in a small business.

#### SUPERFILE. £14.95p

This is a new database program that stores pages of text 64 columns x 22 rows. The program includes word processing and full search facilities.

#### V-NOTCH. £12.95p

Index and Catalogue System, for collections of photographs, recipes, books, knitting patterns, stamps, etc. Up to 3500 items per file full search facilities.

### BUSINESS GRAPHICS

#### HISTO-GRAPH. £10.95p

This program will enable you to present figures in histograms or pie charts. Displays 3 years as a direct comparison or 5 years to show a trend. A unique feature of this program is that all the figures can be printed with the histogram.

### UTILITIES

#### DLAN by Campbell Systems £7.95p

Use your Spectrum to sell your products. Dlan will display messages in up to 11 different typefaces. Will scroll text in any direction.

#### TASWIDE by Tasman Software £5.50p

You can use this program within your other programs to display 64 columns on screen.

#### MF-PRINT by Campbell Systems £6.95p

Enables you to set a print format for your full-size printer within masterfile. Supplied complete with masterfile for £19.95.

#### TASMERGE by Tasman Software £10.95p

Allows you to transfer data from Masterfile into Tasword enabling you to use Tasword for mail merge. The program allows you to specify line and column of each field. For use on micro-drive only.

#### TRANSEXRESS by Romantic Robot £9.95p

Micro-drive utility program which will enable you to back-up all your micro-drive cartridges.

#### TASCOPY by Tasman Software £9.90p

This program allows you to produce 3 sizes of screen copy using Interface 1.

New

#### SUPADRIVE £9.95

This program supplied on microdrive allows you to format a cartridge on the spectrum with 100-105K, retrieve corrupted files or print a full catalogue showing addresses and start lines.

### ACCESSORIES

- Microdrive storage boxes £4.95p
- RS 232 lead £11.50p
- Monochrome monitor connector £11.50p
- RGB monitor connector £45.00p
- Centronics interface £44.90p
- 3 1/2" floppy discs £4.81p
- Continuous Paper 2000 sheets £12.98p
- Continuous labels 1000 £6.65p

Add £1.00 post for labels. £3.00 post for paper.

### MICRODRIVE CARTRIDGES

- Blank microdrive cartridges £1.99p
- Microdrive storage box with 10 cartridges £22.45p
- Microdrive storage box with 20 cartridges £39.95p

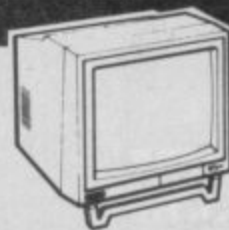

### MONITORS

Philips 7502

Ex VAT Inc VAT

- Philips 7502 monochrome £75.00p £86.25p
- Philips 8533 RGB + C/V £250.00p £287.50p
- Spectrum monitor lead £10.00p £11.50p
- Spectrum RGB interface £39.13p £45.00p

### PRINTERS

#### Dot Matrix

- Seiksha SP1000 RS232 £150.00p £172.50p
- Seiksha SP1000 Centronis £179.00p £205.85p
- Brother M1109 £185.00p £212.75p
- Epson LX86 £215.00p £247.25p
- Taxan Kaga £250.00p £287.50p
- Epson FX85 £368.00p £423.20p

#### DAISY WHEEL

- Silver Reed EXP 400 £215.00p £247.25p
- Brother HR15XL £430.43p £495.00p

Delivery of monitors & printers £5.75p

### DISC-DRIVES

- Discovery 1 by Opus 180k £115.00p
- Discovery 2 by Opus 360k £199.00p

### OPUS DISCOVERY SOFTWARE

- Business Pack £17.95p
- Sales/Purchase Ledger Invoicing £25.00p
- Tasword Three £19.50p
- Stock Control £13.95p
- Omnicalc 2 £21.90p
- Masterfile+MFprint £22.95p
- Superfile £14.95p
- V-Notch £12.95p
- Histo-graph £14.95p
- Dlan £10.95p
- Transexpress £14.95p
- Tascopy £12.90p

All programs supplied on 3 1/2" discs.

### DISCS

- 10 x 3 1/2" blank discs £27.00p
- Box to hold 12 discs £5.50p



## Write or Rom?

The bottom three lines make up the command and status window. *Loading* and *Saving* files, finding, replacing and deleting bits of text all take place here. Typing *E* in the command window starts you editing in the big screen. *Break* gets you back to command level.

The commands are all fairly simple, single-key, and the repertoire is fairly limited. As well as the main commands above, there's a 'display text before printing' option. This shows your opus on screen pretty much as it will appear on paper. The display can be in either 32- or 64-column text, but unlike *Tasword* you can only edit in 32-column mode. The software can use tape or Microdrive without problem.

Editing is simple enough. Word-wrap and justification aren't shown on screen whilst editing is in progress (that's what the display text option is for), but end of paragraphs are.

As this is all happening in a printer interface, you might reasonably expect printer options aplenty. There are. There's the usual condensed,

double-width, bold and underlining available, but there are also facilities to send any sequence of codes to your printer. So, no matter how peculiar and non-standard your facilities are (and some people's are right weird), *RamWrite* should be able to get at them.

That's about it for the word processor. It's a fairly simple beast, more suited to letter writing, invoice printing and similar small jobs than thousand-page theses, but none the worse for that. It took me about ten minutes to get everything going for the first time with my trusty Taxan (Epson compatible) printer. Not bad.

Then there's the printer interface side of things. Using *LPrint* from Basic does the business with little or no problems, and you have the choice of expanding tokens or just sending the codes straight through.

There are two kinds of *Copy*. One does a conventional (if squashed) pixel by pixel copy of the screen on to the printer; the other is much faster, and just copies characters from the

screen. This is the mode that the *Ramprint* starts up in.

The documentation leaves a lot to be desired. It's eight pages of paperback size, photocopied dot-matrix output. It's fairly incomprehensible at times and with more than a couple of spelling mistakes. Common sense is usually enough to drive the product, but there's nothing in the handbook about running the interface from machine code, or any of the common word processors. Which is a shame.

Niggles notwithstanding, Ram has produced another little cracker. It's a good idea, and quite nicely implemented. Not as exciting as the Music Machine, but, in its own way, just as worthy of success ■

Rupert Goodwins

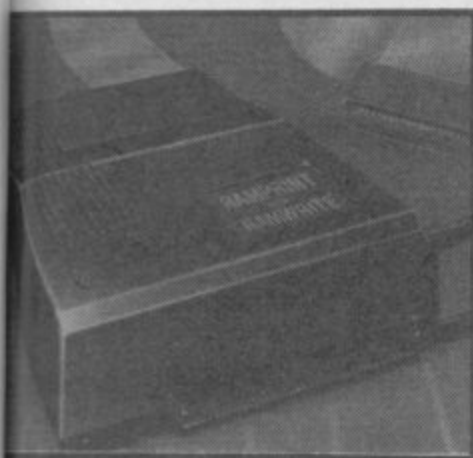
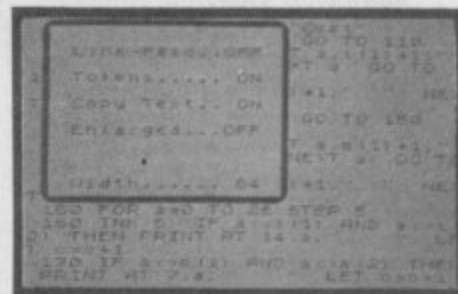

**R**am Electronics, no doubt flushed with success after its Music Machine, has produced the *RamPrint* parallel printer interface. Why splash out for this one rather than others available?

Ram has tried to make it more than just another port. For starters, there's the joystick port for those who play, as well as write, classics. The built-in printer driver software and Centronics cable are fairly standard, I suppose, but the ace is *RamWrite*.

*RamWrite* is a word processor. It's built into the interface on Rom in much the same way as Basic is built into your Spectrum, so it's available as soon as it's turned on.

Typing *LPrint* "© word" gets things going. *RamWrite* revolves around two windows, the biggest of which is used for editing. This takes up the top 21 lines of the screen and displays the document being worked on.

### DATA-SKIP PRESENTS:



These are all real Spectrum screen-shots!

## VIDEOFACE

### DIGITISER



With the Videoface you can transfer television pictures into Spectrum SCREENS. With this SCREENS you can do whatever you like. You can LOAD them into a drawing program or make hardcopies on a printer (see examples) For the Videoface a video-out signal is needed so you can use a video recorder, camera or scart-television.

You can even use another computer as a transmitter. What would you think of a Commodore screen in your Spec??

The Videoface scans continuously and because of its speed, it appears you're watching a digitised movie!

The Videoface produces a high-res 256 x 192 x 4 bit screen.

The software is fully menu-driven and is Beta and microdrive-compatible.

Slice adjustable while scanning. Always stores the latest six screens for animations! The Videoface digitises a picture in 0.27 seconds!

And you can use it for fun, computer art or professional aims. So why hesitate? Rush to the mailbox and order now!

The Data-Skip Videoface digitiser is £69, including P&P and VAT.

Trade enquiries welcome, please contact us: (0) 1820-20581 Data-Skip, L. Willemsteeg 10, 2801 WC Gouda, Holland

\*Also available from Romantic Robot 01 625 9463

#### Data-Skip digitiser

Please send me \_\_\_\_\_ Videofaces at £69 each, VAT and P&P is included.

I enclose Cheque or Postal Order for £ \_\_\_\_\_

Made payable to Data-Skip, Gouda, Holland

Name \_\_\_\_\_

Address \_\_\_\_\_

\_\_\_\_\_

\_\_\_\_\_

Signature \_\_\_\_\_



## I AM THE LAW... I AM JUDGE DREDD

The most popular comics character in the U.K. appears in his own graphic album series published by TITAN BOOKS. Over 25 volumes of JUDGE DREDD are now available at your local bookshop.

Send away for the JUDGE DREDD catalogue containing the full line of DREDD books and merchandise.

Available by mail order from the science fiction and comics specialist shop:

FORBIDDEN PLANET,  
Dept. JD,  
23 Denmark St.  
London, WC2H 8NA.  
Tel- 01 980 9711

Now Available:

- JUDGE DREDD in CITY OF THE DAMNED.
- ROGUE TROOPER BOOK 5.



## Sinclair Surgery

### Spectrum on the blink?

#### Rupert Goodwins has a cure

software. The extra circuitry in a 2068 might well interact with other kinds. Interface 2s are in short supply at the moment, so try Ram Electronics or Kempston.

### Yet another Saga

I am thinking of getting a Saga 1 Emperor keyboard for my Spectrum+. How do you fit one to a Spectrum? Is there any soldering involved, and how complicated is it? Can Microdrives and other bits be connected without any trouble?

**Alex Showell**  
Eltham  
London

● The Saga keyboards, like most keyboards, don't need any soldering, but you do need to take your Spectrum printed-circuit board out of its case before putting it into the Saga. Any add-on that fitted your Spectrum before the metamorphosis should fit afterwards without any problems.



The easy-to-fit Saga

### No hope on hi-res

I've got a 48K Spectrum, a Kempston centronics Interface (software on tape) and an Amstrad DMPI dot matrix printer. The text software works, but none of the high-res programs will produce hi-res copies of the screen. And I'd like to know how to produce double width, and so on. Help! Bye.

**R Tait**  
North Island  
New Zealand

PS You're one of the best computer magazines I know. ● The Amstrad DMPI is a little long in the tooth nowadays, and it can't cope with standard high resolution commands. You can send it a stream of bytes to print out as a graphics image. To send a chequerboard pattern try:

```
10 LPRINT
CHR$(27);"K";CHR$(0);CHR$(20);
20 FOR F=1 TO 20: LPRINT
CHR$(BIN 10101010); : NEXT F
```

Change the 1s and 0s after the Bin in Line 20 to change the pattern. If you want to copy the screen to the printer, have a

look at the screen dump program on Page 79 of the September issue of **SU**, but omit lines 10,20,30 and 110: and change Line 50 to  
50 LPRINT CHR\$(27);"K";CHR\$(1);CHR\$(2)

See the reply to Pauline Winter elsewhere this page for more about this program

The DMPI only has a single special mode of printing text, and that's double width. Turn it on with Chr\$(14), and off with Chr\$(15).

PS And it's getting better. . .

### Interface and family trace

Can you help me with the following: a) Can an adaptor be purchased to connect a Spectrum+ with a QL monitor? b) Is there a program available for the Spectrum+ to cater for genealogy, as I have a number of tables I would like to put on to the computer.

**E.Wolleson**  
Ruislip  
Middlesex

● a) Yup, try Transform on 01-658 6350. b) Programs for genealogy don't grow on trees, y'know! Seriously, there was one for the Spectrum from an off-shoot of an engineering firm in, I think Leicester, but I can't remember their name - it was years ago now. If anyone else can remember their name write to me (c/o Sinclair Surgery) and between us we'll tell the world

### Spectrum power struggle

A friend plugged in a ZX Printer to my old faithful 48K Spectrum when the power was on. Now Save and Load with Code work fine, but trying to write any Basic program puts funny things on the screen and it crashes. Clear works over 32,000, but not under 25000. I think it's the 16K Ram that's faulty, but I'm not sure.

**Jari Komulainen**  
Turku  
Finland

● A major problem with Spectrums is this plugging of stuff in with power on. Much damage can be done. In your case (black ABS plastic), it might be the 16K Ram chips (type 4116), the ULA or even the Z80.

### Hit the speed limit

I read that the Loki would use a Z80H, which is compatible with the Z80 used in the Spectrum, but twice as fast. Could I get one and replace the Z80 in my Spectrum with it, and would it go faster? Might I need some extra components, like a new crystal? Could I switch between the two?

**Nick Clarke**  
Rowley Regis  
Birmingham

● An old favourite, this. Yes, the Z80H does waltz along at twice the speed of the humble Z80A hidden deep within your Spectrum, but just replacing one for t'other would do no good, as the Z80 (A or H) is told what speed to go at by the rest of the Spectrum's circuitry. As you seem to be aware, the speed of the whole caboodle is set by a quartz crystal, and while doubling this speed would indeed make a Z80H run at twice the speed, the rest of the circuits wouldn't be able to cope. Nice try, though!

### Connecting with Timex

I have a Timex 2068 and I want to add a joystick interface to it. Since the two joystick ports built in don't work with any software that I can run, can I connect a Kempston joystick interface (or any others) to it?

**Orjan Kjellberg**  
Goteborg  
Sweden

● The safest interface to use would be an Interface 2 from Sinclair or any interface that supports Interface 2 type

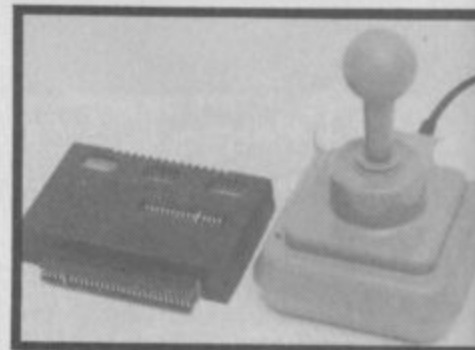

A compatible interface

### Bunged up Biorythms

Help! I've got a Spectrum 48K, Interface 1 and a Brother M1009 printer. I want to copy the screen to the printer, as I've got a biorhythms program, but it just prints ???'s from the Print option.

I've tried the program in the September Surgery, but I can't find Chr# (Line 30), and Line 70 won't go in, even if I threaten to throw my Spectrum out of the window!

**Pauline Winter**  
Maidstone  
Kent

● Er yes, the gremlins old escape from the back of the mag to get to the listing in September's Surgery. Line 30 should be Chr\$ - not Chr#. The bit of Line 70 that's kerpiffle is the bit that goes: +2\*POINT)\* (y+1)+4\*POINT. It should read: +2\*POINT)\* (y+1)+4\*POINT.

This program will only work for Epson compatible printers. If your Brother isn't, then change Line 50 to cope with whatever the special codes are that it needs. Printer manuals invariably have this information hidden away as 'Graphics Printing Mode', or Bit Image Setting, and it will probably take the form of Escape (Chr\$ 27), followed by two or three special bytes

Another Surgery over. More diagnosis done. Actually, I've got a hardware problem of sorts myself - my cat likes to sleep on the printer, 'cos it's warm. And this stops the paper from moving properly, so me output gets all crumpled. Any ideas on solving this without upsetting the feline at fault? Strange how printers seem to cause problems. . .

And don't forget, keep exercising that keyboard. We don't want to see any flabby rubber now, do we? Come back in a month's time for another checkup, and a repeat prescription.

*Rupert Goodwins*



# Rubot rides out

Them that know reckon that the hardware is only as good as the software. With Rubot the hardware's pretty good, but the software depends on what you do with the poor thing.

Owners of buggys invariably take a delight in making their beasts bash against the nearest solid objects and turn away in a daze. What the psychologist calls a conditioned response.

Others take great pleasure in persuading their hardware to engage the cat in hot pursuit. Shrinkers everywhere know this as out and out nastiness.

So here are two programs to give the Rubot a chance to sample the joys of dubious droidery.

Program 1 is a very basic Basic maze-learning program. Even that's being a bit grand. All it does is trundle Rubot forward until it hits something bigger than

itself. Then Rubot turns until it gets an all-clear ahead, and then continues. The clever bit comes when you press a key on your Spectrum. With heartwarming faith and Mensa-like intelligence Rubot will return to its starting point without hitting anything. At least that's the theory.

Program 2 is a bit simpler. All it does is make Rubot respond to Interface 1/128K+2 joystick commands.

If you're feeling particularly bright you might like to combine Programs 1 and 2 so you can teach Rubot a path using a joystick.

**NOTE:** Depending on exactly how your Rubot is wired you may need to swap the values for *Forward* and *Back* in Line 140 of both programs. Similarly, *Left* and *Right*, and *Bumpleft* and *Bumpright* may need a little juxtaposition

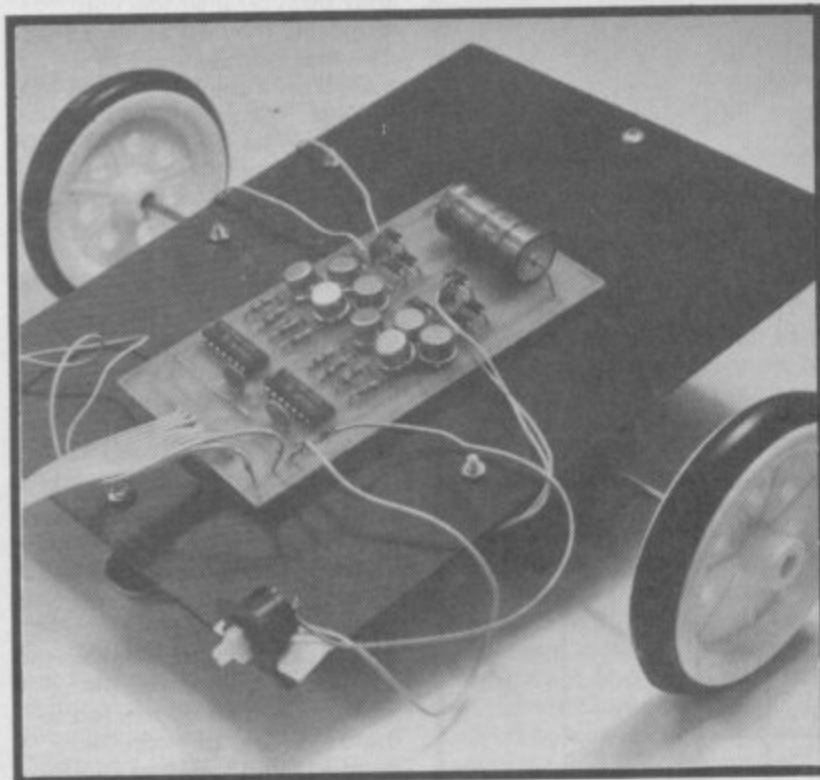

```

100 REM Rubot Joystick Jive
110 REM (c) Rupert Goodwins
120 REM      1986
130 REM set up everything
140 LET left=9: LET right=6: L
ET forward=10: LET back=5
150 IF INKEY$="9" THEN OUT 31,f
orward
160 IF INKEY$="8" THEN OUT 31,b
ack
170 IF INKEY$="7" THEN OUT 31,r
ight
180 IF INKEY$="6" THEN OUT 31,l
eft
190 IF INKEY$="" THEN OUT 31,0
200 GO TO 150

```

```

100 REM Rubot Maze Trace
110 REM (c) Rupert Goodwins
120 REM      1986
130 REM set up everything
140 LET left=9: LET right=6
150 LET forward=10: LET back=5
160 LET bumpleft=223: LET bumpright=239
170 LET bumpboth=207
180 DIM a(200,2): LET stage=1
190 GO SUB 390: REM start clock
200 LET dir=forward: GO SUB 430
210 IF IN 31<>nobump THEN GO TO 240
220 IF INKEY$<>"" OR stage>198 THEN GO TO 310
230 GO TO 210
240 IF IN 31=bumpleft THEN LET dir=right
250 IF IN 31=bumpright THEN LET dir=left
260 IF IN 31=bumpboth THEN LET dir=back
270 IF dir=forward THEN GO TO 210
280 GO SUB 430
290 IF dir=back THEN LET dir=left: GO SUB 430
300 LET dir=forward: GO SUB 430: GO TO 210
310 REM Now retrace steps
320 LET time=a(stage,1)-a(stage-1,1)
330 OUT 31,15-a(stage,2): REM reverse step
340 GO SUB 390
350 IF FN t(<time THEN GO TO 350
360 LET stage=stage-1: IF stage>1 THEN GO TO 320
370 OUT 31,0: STOP
371 REM Read timer
380 DEF FN t()=PEEK 23672+256*PEEK 23673
390 REM Start timer...
400 POKE 23672,0
410 POKE 23673,0
420 RETURN
430 REM change direction
440 OUT 31,dir
450 LET a(stage,1)=FN t()
460 LET a(stage,2)=dir
470 LET stage=stage+1
480 FOR f=0 TO 300: NEXT f
490 RETURN

```

## THE WIMP'S WAY OUT

We've arranged with Magenta electronics special prices on all the gear you'll need to build our Rubot Buggy.

There are two versions:

The Electrics kit gives you everything you need apart from motors, wheels and base and is designed for moderately experienced people who want to design their own look of buggy and maybe pinch the parts from somewhere else.

However, if you are starting completely from scratch and want absolutely everything we have the Absolutely Everything Kit which includes everything you need to build a complete buggy. It has proper wheels, base, switches and best of all comes with a ready-to-assemble circuit board - all you have to do is put the parts in the right place and connect up leads - no track cutting is necessary. This version will also include a special instruction sheet designed to be even easier to understand than the stuff printed here. We have even arranged a special deal on a suitable soldering iron and solder.

### PACKS

The Electrics (does not include motors, wheels or base)	£10.
Full Buggy Kit	£20.
Special Offer Soldering Pack (Antex XS 25 watts 240V iron plus stand plus solder dispenser)	£9.90

Please add £1 postage and packing with each order (Multiple orders still single £1)

Fill out the coupon and send it to: rubot Robot Sinclair User, Priory Court, 30-32 Farringdon Lane, London EC1R 3AU.

Makes cheques payable to Magenta Electronics.

You may also pay by Credit Card:

Card Type: (access, Barclaycard, Trustcard) .....

Card Number: .....

Your: .....

Name .....

Address .....

## How it works – the techy background

To the novice roboteer, the circuit diagram seems daunting. The trick, like software, is to look at each bit by itself and when you understand how it works try and fit it all into the rest of the robot.

Let's start at the motors. These, let's face it, do all the hard work of hauling the rest of the unit about. Rubot has two, one for each driver wheel. They run from DC, so if you put a 5V torch battery across the motor terminals it'll turn. If you then reverse the battery, the motor will run in the opposite direction.

This useful little trick is put to work in the steering of Rubot. When power is applied to both motors in the same direction at once, the unit will head off in a straight line. Reverse the supply to the left-hand motor, for example, and the left-hand edge of the unit will suddenly try and move backwards. As the right-hand motor (and attached edge) is still resolutely ploughing forwards, Rubot will execute a smart anticlockwise spin until both motors are set in motion in the same way again. This trick reversed can, of course, be used to turn the unit clockwise. So Rubot can turn.

So we need to be able to reverse the voltage to both motors. It would be nice to be able to stop the things as well.

To reverse the motors, we need to connect either of each motor's two terminals to either +5 volts or 0 volts. If we connect one to +5 volts, and the

other to 0 volts, current flows one way and the motor spins. reverse the connections, and it goes in the other direction. Connect both to 0 volts, or both to +5 volts, and no current flows, so the motor just doesn't go.

When you've got that little lot clear, have a gander at the circuit diagram for the Motor Board – Diagram 1. In the middle you'll see two symbols which stand for the two motors. They look like this:



Each straight line on the circuit diagram stands for a connection. So, looking at one of the motor symbols, you'll see two straight lines appearing out of the side. These are the motor terminal lines. The first thing that's attached to these lines is one of these:



This is called a capacitor, and its job is to keep the motor clean. Electric motors can make an awful lot of electric rubbish – if you've ever tried to listen to a radio when someone's using an old, unsuppressed hair drier you would probably have heard the rubbish as noise on the frequency you were listening too. The little motors in Rubot can make a lot of noise too, and that can interfere with the rest of the circuit and even (horrors) your Spectrum. The capacitor catches the rubbish and disposes of it before it can get out and on the rampage.

Next on the motor lines,

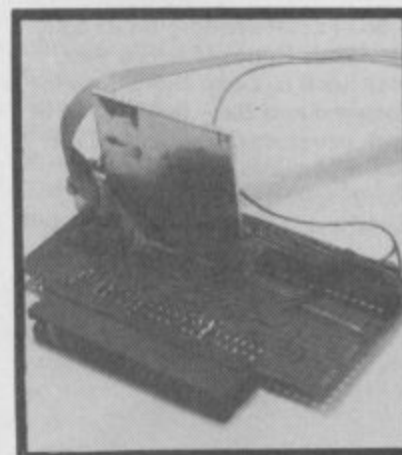
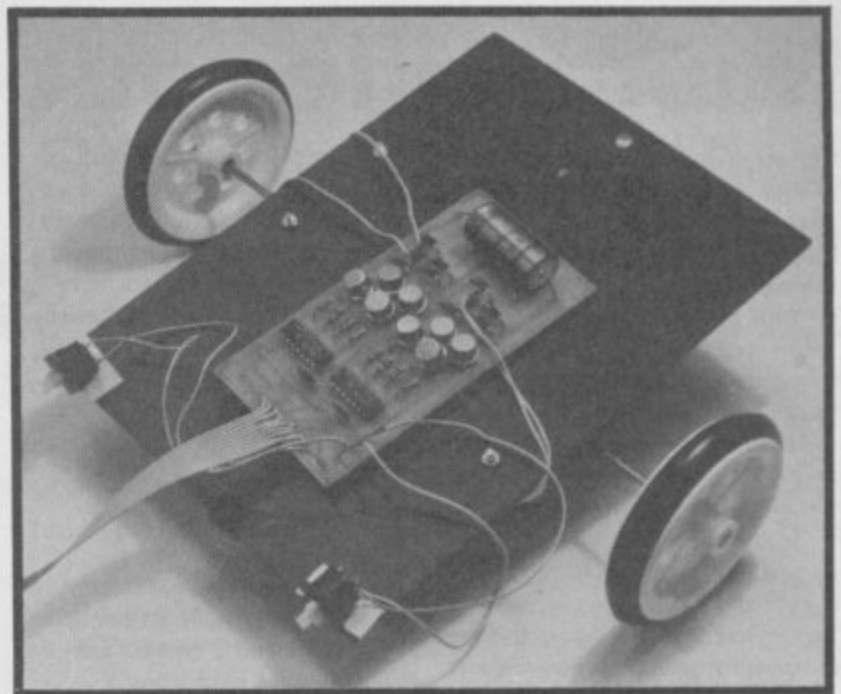

you'll see these:



These are called diodes, and they do a similar job to the bits of electrical rubbish that are too meaty for the capacitor. Now we come to the business bits, the transistors. Transistors are

the stars of the show, and look like this:



PNP and



NPN. There are two types, but they both do a similar job. Basically, they act as switches. The first kind (called PNP) switch on if they're given a low voltage. The second (NPN to their friends), switch on if they see a high voltage. You'll notice they have three connections each. The connections are called emitter, base and collector (E,B and C on the picture above). The reasons for these names are lost in the mists of time, but you apply the voltage to the base, and the switch closes between the emitter and the collector.

Back to the circuit diagram. Have a look at the bases of TR2 and TR6. If these both receive a high voltage then TR2, being a PNP transistor, will turn off, and TR6, being of the NPN persuasion, will turn on. So the motor line (remember the motor?), will be connected to the 0 volt line through the connector and emitter of TR6. Whoopie, I hear you cry. But wait, cynics. If you look at the other side of the motor, you'll see an identical bit of circuit, involving TR1 and TR5 in much the same way as TR2 and TR6 were configured. If we take the bases of these transistors low, then TR1 will turn on, (PNP, remember) and TR5 will turn off. This connects the other side of the motor to +5 volts, and whizzzz! The motor will run.

So why not just connect the voltages straight to the motor, instead of through this complicated transistor business? (If you don't understand the question, then take a short break, play Light

◀Diagram 1: The motor board. This is the circuit that is mounted on to the Rubot itself.

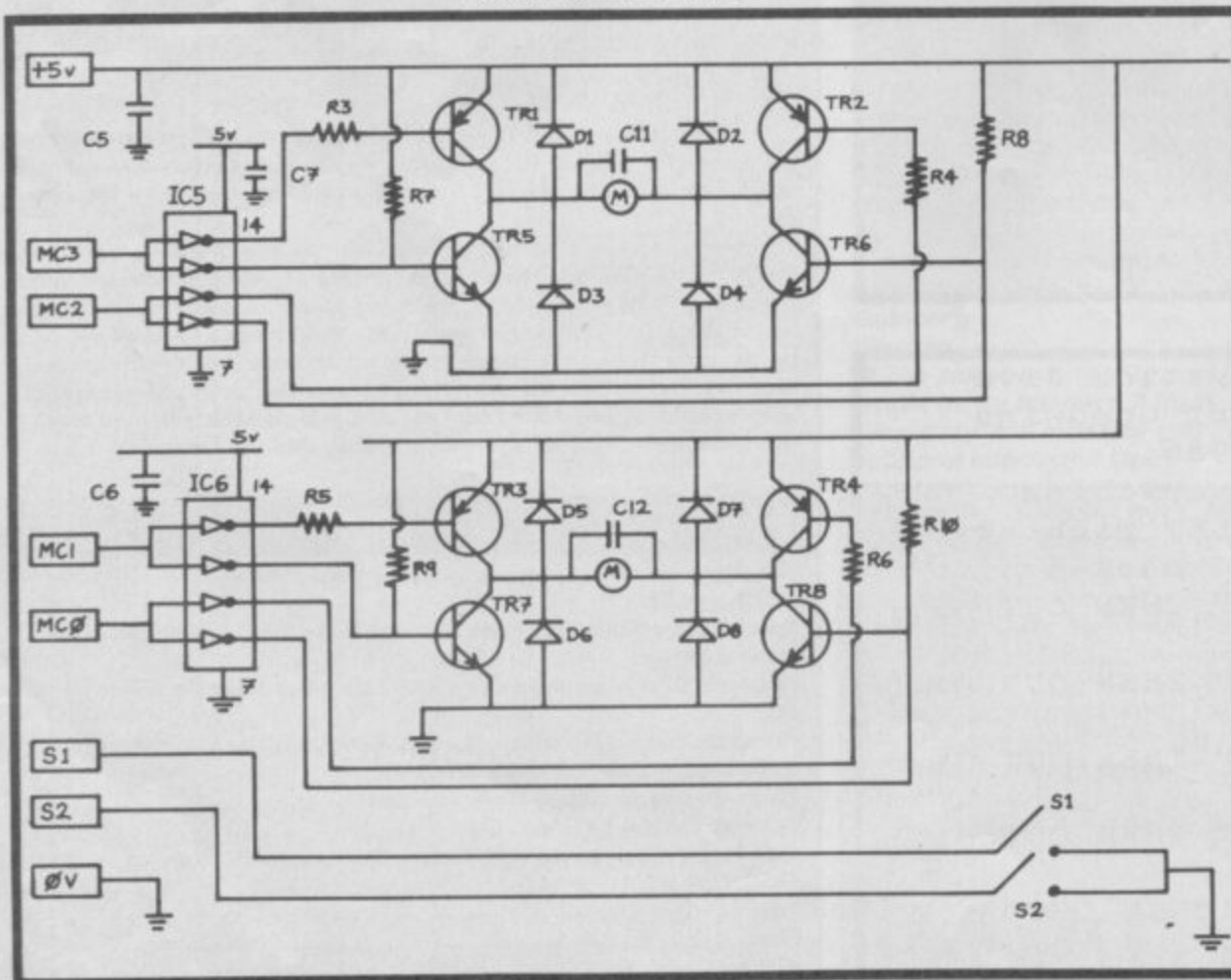

Force, and try again.) The transistors are needed as the motors are greedy brutes and need quite a lot of power. But the computer is a subtler beast, and is only happy when dealing with little tiny snippets of electricity. The transistors operate like switches: a little bit of power from the micro is enough to switch on or off the big power to the motors to keep them wheels a'turning. They still need a bit more than the computer can deal with, so IC5 and IC6 (with the help of resistors R3 to R10) do a little more power-level conversion to the signals from the interface board to feed the transistors. This business of converting power levels is called amplification, and is exactly what your hifi amp is doing when shoving a tiny little signal from a record player cartridge through your masso-whumph 100 watt speakers.

So we've tracked the signals down to the interface board. These signals (MC0 to MC3, for Motor Control) switch the terminals of the motors between +5 volts and 0 volts. Since this is a computer-controlled beastie, it would seem a good idea to switch MC0 to MC3 from the computer. That's what ICs 1 and 3 are there for. IC1's job is to detect when the computer wants to send out a signal. It manages this by constantly looking at IORQ and A5. A5 is an address line, and the computer uses this to identify which peripheral to talk to, like the loudspeaker, cassette or keyboard. A5 isn't used by anything within the Spectrum, so we can snaffle it. IORQ signals that the computer wants to use a peripheral rather than memory. So when both A5 and IORQ are active, IC1 knows that the computer wants to talk to Rubot. If it wants to write to Rubot, which is when it sets MC0 to MC3, then it also makes WR (write) active. If it wants to check the switches, then it makes RD (read) active. IC1 detects both of these, and switches in the appropriate bit of silicon. IC3, when switched

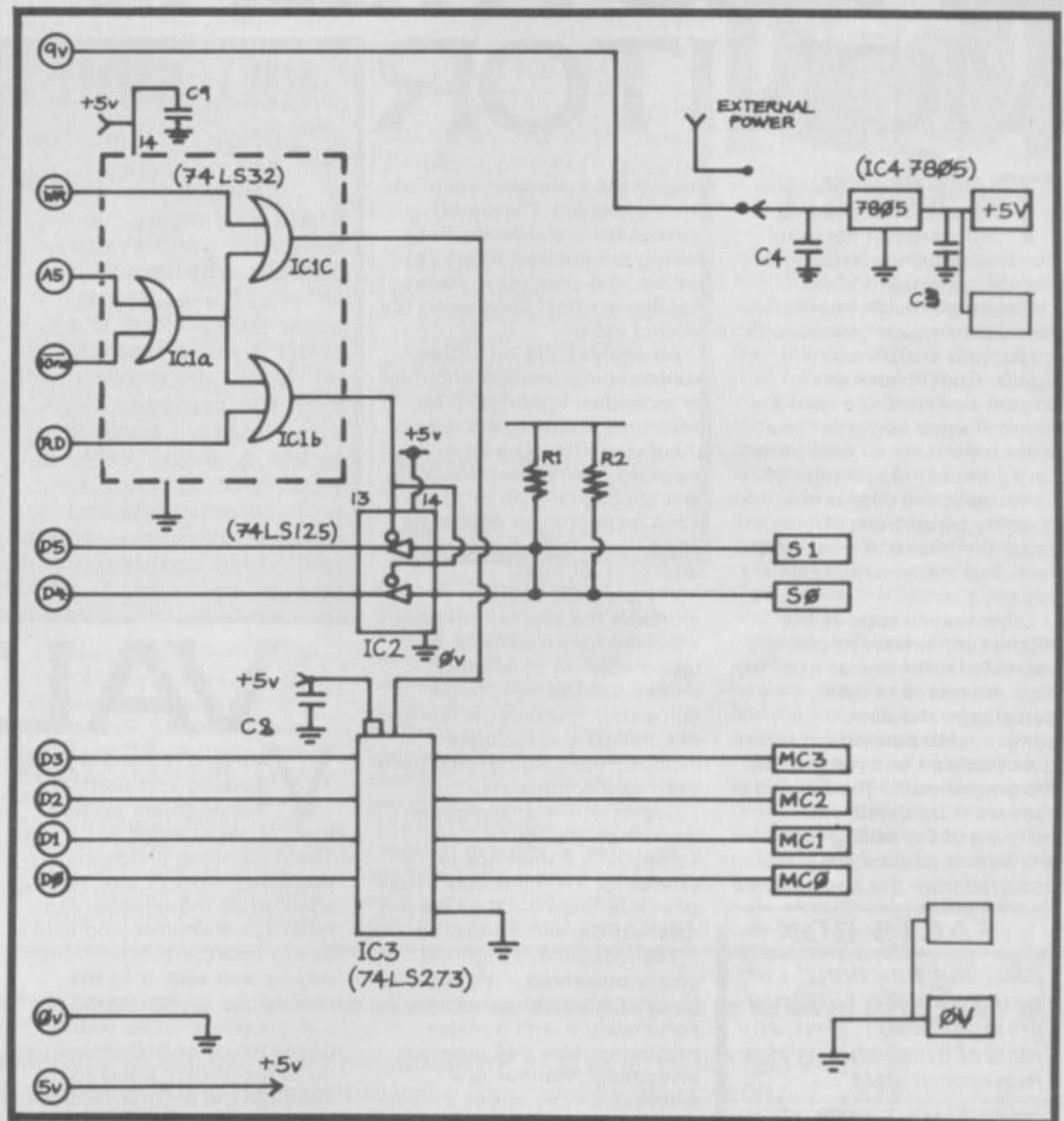

on, copies data from the computer to MC0 to 3. Its speciality is that, when it's switched off again, it remembers that data and keeps it on MC0 to 3. So the computer just needs to write the information once, and can then get on with something else. Until it comes up with some new data, IC3 will remember. Reading the switches is a similar sequence. IC1 turns on IC2 instead of IC3, and IC2 copies the information from the switches into the computer. Unlike IC3, IC2 turns off

completely when not selected. Address line A5 corresponds to Address 31. The Basic command *In 31* will tell the interface that the computer wants to read the switches, and will come back with the status of those switches. If neither are closed, then it'll come back with 255 (as everything will be high). The switches are connected to D4 and D5, which have decimal values of 16 and 32, so if the switches get closed, these lines will go low, and their value will be subtracted from that 255 we just got.

▲Diagram 2: The interface board which plugs into the Spectrum

The command *Out 31*, number writes that number to the data line. If you do *Out 31,1*, then D0 will go high. 2 will put D1 high, 4 D2 and 8 D3. Any combination of the above numbers will put the equivalent combination of D0 to 4 high, and the motors will spin!

The last bit of silicon skulduggery concerns IC4. This is a voltage regulator, and keeps a nice, steady voltage going to the motor board even when the motors are chopping and changing. IC4 can get its power either from the Spectrum or from somewhere else. It can take the power from the Spectrum if you have just such a power supply, but ordinary 48K and Spectrum + users are unlikely to be so lucky. To find out, read the label on the base of the power supply. If it says 2A or more, you're OK. If it's less than that, then you'll have to connect a 9 volt power supply or large 9 volt battery (like PP9) to pin 1 of IC4, and not connect it to the 9V line of the Spectrum ■

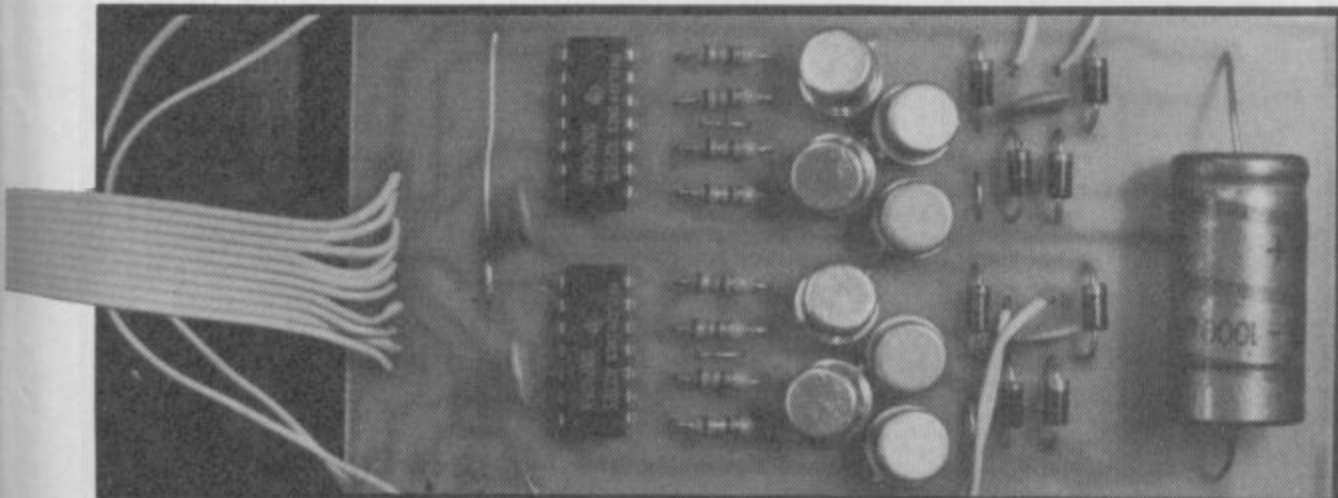

# INVESTMENT MONITOR

**T**he Investment Monitor from Michael Slatford Software is a personal portfolio valuation system for the 48K, priced at £12.00.

The program can handle data for investments in shares, unit trusts, gilts and investment bonds. Each investment is treated as a card in a card-file index of up to 50 cards. You enter the details on each new card - the name and type of investment, the date and quantity bought, the buying price, the total cost (including fees) and the latest date and price.

Other details such as the highest and lowest prices, the estimated value and any gain or loss, expressed in real, percentage and annual compounded percentage terms are calculated and retained by the program until the next time the card is up-dated. An estimate of the selling fees at any time is automatically deducted from the book value

to give the estimated value of the investment. Details of income from dividends and selling are entered when up-dating, and changes in name or holding are best done using the amend option.

An analysis option allows statistical information about all or individual holdings to be examined showing the date of the last up-date, the amount invested, the realisation value and the capital gain or loss. Total income from dividends and sales is included to give a total gain (or loss).

The portfolio section monitors the amount of money allocated for investment by taking account of whether money from sales is to be reinvested. It shows the number of holdings and includes income from holdings that have been sold completely.

Copies of the analyses can then be printed out - Kempston's E interface is catered for - it is possible to use other interfaces but they are not covered from within the program.

The manual is, I'm afraid, poorly presented - it's just five loose sheets in an envelope. Fortunately it isn't a major requirement for this program. **Investment Monitor** is a practical, simple to use means of watching how your investments are doing. It doesn't set out though to show what those investments may do in the future.

A QL version which is compiled and runs faster with room for up to 90 investments, details of a building society account, that lets income be zeroed at the start of a year and will realise capital gains is also available for £20.00

## KILL SID!!

**P**rivatisation and the Big Bang (the deregulation of the Stock Exchange) have created a huge surge of interest among small savers in Sid, among other things. Yet, the small investor may have no more information than the previous day's price from a newspaper to use as a guide. Now your Spectrum can help by providing detailed information and analysis and which could lead you to even make money!!



# VALTRAK

**V**altrak 4 is a share price-tracking and portfolio management system from Morley Davies Associates. The underlying philosophy is that an analysis of a company's share price movements can reflect performance and leads you to take correct decisions on buying and selling, ie the philosophy of a chartist.

A maximum of 26 weekly prices for up to 100 entered at up to six weekly intervals although the program works on weekly prices. The data for missing weeks will be automatically extrapolated. Once the records are in place they will need to be up-dated regularly with the latest prices. Usually this will mean an up-date of all the prices in a file. Even the authors agree that this is a chore and estimate, conservatively in my view, that to up-date 80 records takes about 20 minutes. Alternatively an interim up-date will restrict the up-date to only those companies where stock is held. At the end of the up-date this option moves straight to a valuation of the portfolio. For this purpose shares are valued at 4 per cent below the latest price to take into account selling fees. The records can also be erased, amended or moved around the file, allowing names to be changed or groupings altered for easy entry of data. Analyses of the data are provided through the *Select Record* and *File Surveys* options on the main menu.

*Select Record* deals with the individual records and produces 5- and 13-week moving averages, weighted and unweighted, for raw and

adjusted (large changes are reduced to less than 10 per cent) prices. A wide range of graphs can also be produced and copied, including log graphs for fast moving prices.

Analyses for all records on file are produced via the *File Surveys* option and include posture tracking. The posture of a share as rising, positive, neutral, negative or falling is determined by comparing the 5 (short) and 13 (medium) week weighted moving averages with the actual prices.

Although **Valtrak 4** can be used from cassette, Microdrive or disc and with either a Sinclair or 80-column printer the manual seems to suggest that only the Technology Research Beta+ disc interface is suitable. While only the use of Morex, Kempston (E) and Lprint III printer interfaces are coded into the program. While a manual of 40 pages looks very intimidating, especially when it

### FACTS BOX

*Basic but functional current value tracking program. Doesn't give any market trend/share value movement data*

#### INVESTMENT MONITOR

Label: Michael Slatford,  
3 Campden Road, South  
Croydon, Surrey CR2 7EQ  
Price: £12.00  
Memory: 48K

Reviewer: *Mike Wanjat*



### "TOTALS" AT 29/12/1984

#### UNITS

Total Investment	£7427.36
Total Realisation	£20196.95
Cap. Gain (171.93%)	£12769.59
Total Dividends	£2022.70
Total Income	£1595.34
Total Return	£21792.29
Total Gain (193.41%)	£14364.93

#### BONDS

Total Investment	£4000.00
Total Realisation	£5870.69
Cap. Gain (46.77%)	£1870.69
Total Withdrawals	£450.00

### FACTS BOX

*A sophisticated share tracking system. Despite great manual for serious investors as an aid for making MONEY*

#### VALTRAK 4

Label: Morley Davies,  
11 Denham Lane, Chalfont St  
Peter, Bucks SL9 0ER  
Price: £24.65  
Memory: 48K

Reviewer: *Mike Wanjat*



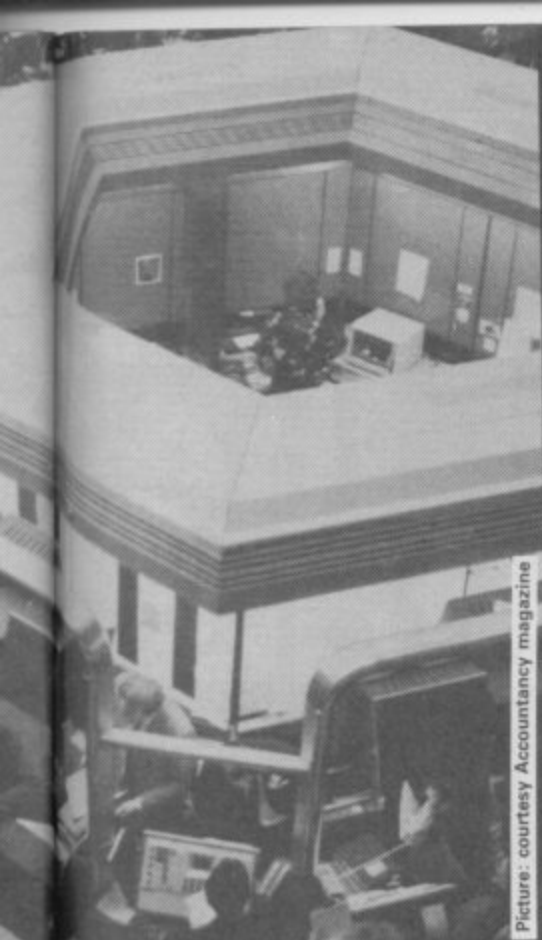

Picture: courtesy Accountancy magazine

# SHARES

**S**hares from Cottage Computing is a database of monthly share prices for the 48K with Microdrive. The database consists of a number of files on three cartridges each containing information on companies in industry groupings.

Shares 1 covers Banks, Beers, Building, Chemicals, Drapery, Engineering, Food, Hotels, Insurances, Leisure, Motors and Newspapers; Shares 2 covers Electricals, Industrials and Property while Shares 3 covers the remaining sectors.

On loading an automatic catalogue produces a list of data files that can be loaded. The file names are arranged with the number of companies on the file in the first three characters followed by the sector.

**Shares** uses the last twelve month's prices to prepare a statistical break-down of performance. To get the best from it you'll have to up-date all the prices each month, done by entering the number of the month followed by the latest prices for all the companies on the file. Once the prices are entered you get a final chance to check them all and re-enter

## FACTS BOX

*Monthly share price database. Limited capabilities, doesn't match up to other programs available*

### SHARES

Label: Cottage

1 Elm Cottage, Randalls Hill, Lytchett, Poole Dorset

Price: £7.50

Memory: 48K

Reviewer:

*Mike W...*



them all if one is wrong. Then the program goes to work. The time for a monthly up-date of all the prices on a cartridge is estimated at somewhere over three hours. If this sounds like hard work Cottage Computing provides it's own up-date service for £2.50 per cartridge per month.

The information which the program extracts is limited to the latest share price for all companies on file and breaking out from all its data those firms

## WORK-OUT



## REVIEW

whose latest price is greater then or less than it was twelve months ago. A list of companies where there has been no monthly share price drop can also be produced. This comparison is based on three month moving-average figures and it's also the only option where the data for the whole cartridge can be extracted at one go. For individual companies a histogram of the twelve month's data highlighting the latest, highest and lowest prices and the percentage change for the year can be drawn. A graph of the moving average price with the latest price superimposed completes the output.

**Shares'** attempt to cover an entire market has unfortunately been made at the expense of features such as details of holdings, that could have been included.

As a result the package falls between two stools

**4** is only stapled, this is one of the most readable I have ever come across. The explanations are simple and relevant.

I once said of an earlier version that it was for use by dedicated dabblers because of the amount of time and effort required. I have not changed that view although **Valtrak 4** with its extra features and increased speed is clearly now a very powerful tool



Reach an estimated readership of 250,000 users per month for as little as £6.00\* (inc VAT)

Or if you are starting your own small business advertise in the supermart for only £20.00 (inc. VAT)

Yes, all you have to do is fill in the coupon below including your name, address and telephone number and send to: Supermart, Sinclair User, EMAP, Priory Court, 30-32 Farringdon Lane, London EC1R 3AU  
Maximum 30 words. Your advert will appear in the earliest possible edition.

Name .....

Address .....

Tel: .....

Have you included the fee of £6.00\* or £20.00?

Make cheques payable to EMAP PUBLICATIONS LTD

\*for second hand sales only

Conditions  
The Advertisement Manager reserves the right to alter, reject or suspend an advertisement without assigning any reason. Advertisements are accepted subject to approval of copy and to the right of the Advertisement Manager to alter, reject or cancel any order without explanation. The Proprietors are not liable for any loss from any cause whatever, nor do they accept liability for printers' errors. The Advertisers shall indemnify the Publishers in respect of any claim, cost and expenses arising out of any libellous or malicious matter or untrue statement in any advertisement published for the advertisers, or any infringement of copyright, patent or design therein. The placing of any order will be deemed to be an acceptance of these conditions.

# NEXT MONTH

## It's all in the stars



And so, another year passes gently by. Another twelve issues of **SU** are carefully filed away and added to the rich tableau that is history. What do the swirling mists of fate have in store for us in the New Year? We talk to a group of the Industry's biggest names and get their predictions for 1987.

We'll also be looking forward with the **SU** preview section to the games that are set to be the hottest around, and giving our customary no-nonsense verdict on the big games of the moment.

If your new 128K+2 is proving just a little difficult to control, our pull-out Guide For New Owners will help you get started. **SU** tells you what the manual was afraid to! Oblivious to the hate mail it will involve and we'll pick out the ten best games ever released on the Spectrum. New owners start your collection here!

Maps, Give us Maps you cry! Following the success of this issue's **Great Escape** and **Glider Rider** guides, we present a pictorial path through more top programs.

Adventure-writing is a funny old business. You may have some great idea for fiendish traps and maps and puzzles, but putting them into a computer is another matter entirely. With thousands of budding game-designers buying adventure-writing utilities, we take a long, hard look and ask: Are they really worth it? Check out the SP with **SU**.

And finally... last but not least, the FREE GIFT. You reeled with the excitement of Future Visions. You swooned over the astonishing Price is Right booklet. Now here comes the ultimate in free entertainment: **The Zapchat** Booklet. Ten of the hottest titles taken to pieces.

In 24 action-packed pages **SU** gives you the low-down on top games such as **Starglider**, **Avenger**, **Sacred Armour of Antirad**, and many more.

As you can tell, the February issue is going to beat them all on everything - value for money, looks, style, news and views. It's a crime not to read it.

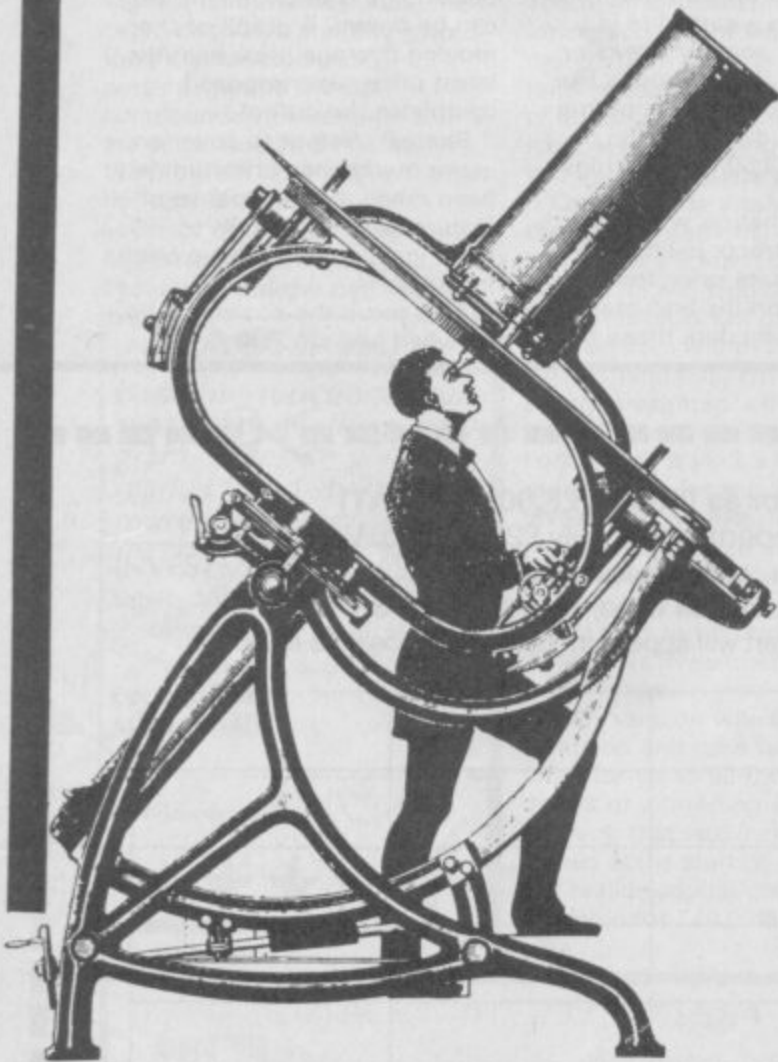

The February issue of **SU**, materialising mysteriously. January 18th, buy it!

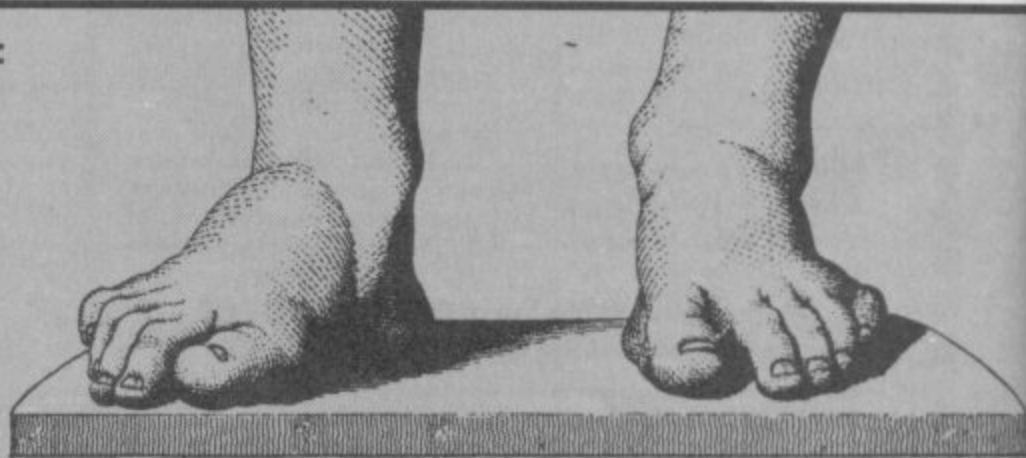



**ON STRIKE!**

**D**eep Strike, from Durell is a novel addition to the massed ranks of simulator programs to emerge over the past months.

Instead of being told that you get to control the most advanced fighter in the history of flying, you get to fight it out with World War I bi-planes.

Your mission, should you choose to accept it, is to protect a bomber on its journey behind enemy lines. On the way you will come into contact with barrage balloons and enemy fighters, every one a hazard to be avoided at all costs.

The game has refreshingly simple controls (up down, left, right, fire and bomb) and allows you to get directly into the action. As you fly around, fighters will crop up from just about anywhere, and attempt to send you ground-ward in a cloud of black smoke. You will have to keep an eye on your fuel gauge and ammunition supply if you are to succeed.

Mainly you have to shoot things however. Rat-atat-tat etc. etc. Streetdate: December. Price: £9.95.



## MAGIC KNIGHT STORMS IN

**H**ere it is folks! The concluding episode of the wonderful Magic Knight Trilogy, from Mastertronic. First there was Spellbound, then came Knight-Tyme. Now, the tale continues in Stormbringer.

In this game, it is Magic Knight's task to defend the honour of his home town, which is being threatened by a malevolent force.

The force in question is the Off-White Knight, an opposing force whose ambitions are far from pure. In his quest for universal domination OWK decides the best place to begin an empire is the very heart of Magic Knight's domain.

Parking his time machine, OWK stumbles upon an empty castle, and takes up residence. The object

of the game is to cast out the evil knight, and return him to his own universe.

The game features a variety of locations, from outside, and above ground, to the cave complex, through the castle and - ultimately - to the Off White Knight's time machine.

The plot seems every bit as complex as the others in the series. Puzzles are numerous and difficult. Objects must be collected, used and shuffled.

With a host of commands available (tickle, wish and smell being some of the most bizarre) Stormbringer looks like a "biggie".

Streetdate: Late December  
Price: £2.99



## BRIAN'S BALLS

**O**h, for goodness sake! Yet another football game! Sometimes I sit for ages, wondering what the world would be like without football simulations.

CDS Software has just brought out Brian Clough's Football Fortunes (titter). Not only does it involve the usual balderdash (eg selling players for ludicrous prices to other teams) but the package involves a 'board' (?). The idea is you and your mates play the game with both the board and micro.

Apparently, the whole caboodle was written with plenty of advice from Brian himself.

And the worst part is still to come. CDS even dares to suggest 'players' should indulge in the absurd phrases as uttered by Sir Bri himself. 'Over the moon' indeed. Pah!

Streetdate: January  
Price: £14.95

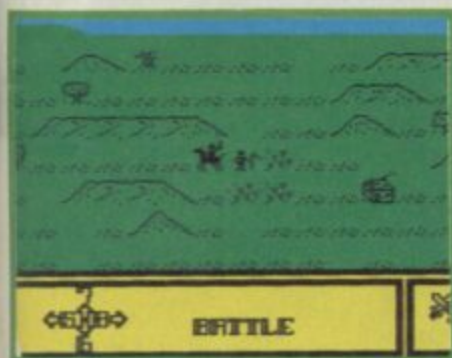

## SWORD & THE GREEN GOO

**S**word and Shield, from Black Knight software is very similar to Valley, the completely brilliant game about running a small village in olden days. Although littered with interesting features, it really comes down to the old routine - run a village, planting crops etc and hope too many people don't die of the amazing green goo that sweeps in from the north every 6 turns...

The game has lots of interesting additions to this plot, though. Battles crop up at the most inconvenient times, costing you men who could be put to far better use in the fields.

Dragons are rumoured to roam the lands where sensible people fear to tread, and the whole game looks rather impressive. If you try to rule too firmly, the proletariat may rebel, scarper off to the hills and hang out as rebels.

It sounds like just the thing to play on a cold night, when one's mind turns to power-crazed domination.

Streetdate: December.  
Price: ££5.95



## SIDE TRACK

Everyone knows that as far as skittary-round-the-track race games go, Scalextric is the best. More details on Scalextric next month. But in the meantime, feast your eyes on the following features:

- 2 player game.
  - split screen.
  - 3D graphics.
  - Design your own tracks.
  - 17 pre-programmed tracks already included.
- Crazy stuff huh? It's from Scrabble authors' Leisure Genius. Streetdate: December. Price: £9.95.

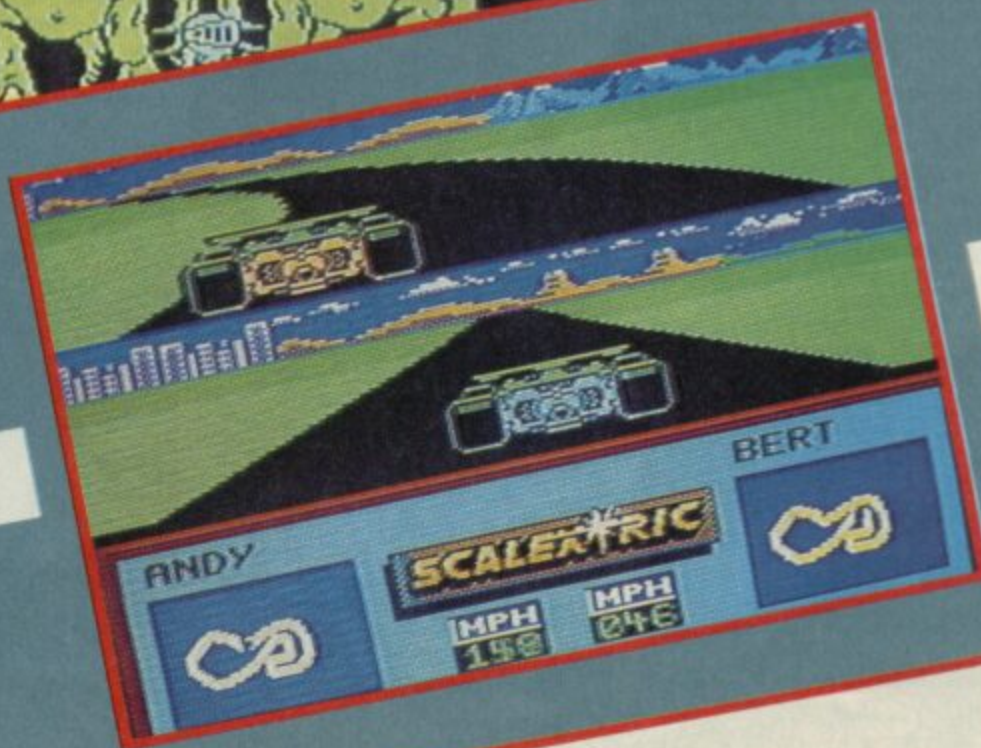

## NATTY SUPER SOCCER

Football games seem to pop up every now and again. After last month's report on Peter Shilton's Handball Maradona, Ocean manages to produce the 'long awaited' Super Soccer.

Apparently, Super Soccer is the most realistic simulation yet. Although the game looks remarkably similar to a good deal of other soccer simulations, it does boast some rather natty little features.

While controlling your player, you can belt left and right across the screen, running faster and slower at will, and stopping to make 90 and 45 degree turns, you can run yourself ragged with the

flick of the stick.

It is possible to alter the team names, too and progress through a tournament, taking your team on to higher things.

A more unusual feature is that you can play as goalie as well as the other players, and try your hand at saving the computer-controlled shots. Perhaps this puts Handball Maradona on trial for value-for-money?

A practice option is also included, permitting you to have a go at the game without being kicked to death by other players.

Streetdate: December.  
Price £7.95

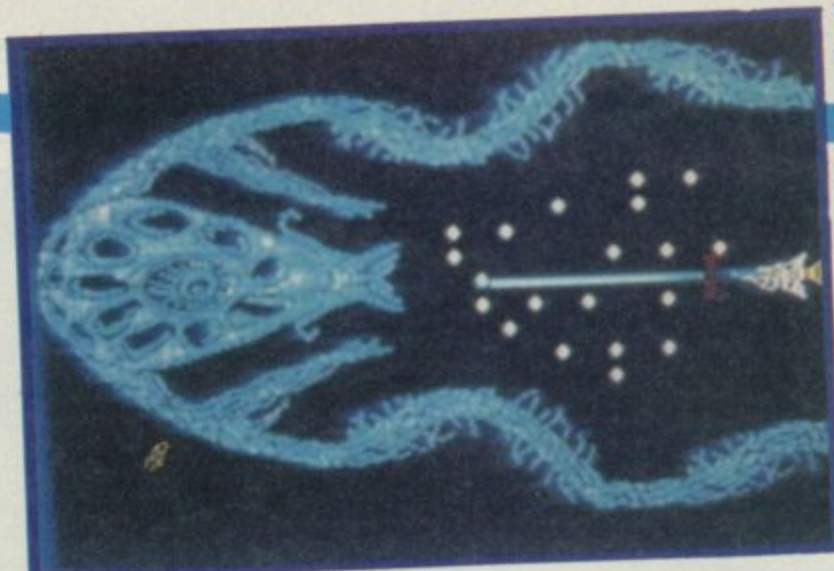

## WARP RATTLING IN NEMESIS

Streuth! Look at these graphics. "Ha. Just another arcade picture, I bet." I hear you cry. Well, hold on to your horses, why don't you? This is Nemesis on the Spectrum from Konami.

The classic arcade game was once converted to the MSX, and was described as 'the best game ever on the MSX' which wasn't an altogether difficult feat to achieve. Well, now it's being coded for the Spectrum, and looks pretty impressive.

The storyline of this scrolling space shoot-out is simple. The World is about to be destroyed by an alien force. Gunning your Warp-Rattler space craft through alien defences, you must fly toward the brain of the advancing war-planet and destroy it. Will you succeed? Not ruddy likely, there are eight levels, each increasingly more impossible and a positive multitude of alien beings queueing up to kill you.

It's possible to employ a wide number of weapons, you have dual-direction lasers, shields, missiles and a speed-up mode. There is also a very bizarre feature allowing you to create another ship to join on to your own, increasing your firepower. Very odd.

Streetdate: December/January.  
Price: £7.95



## STILL FAFFING ABOUT IN THE FOREST

In Legend of Kage, the latest from Ocean, you are presented with a return to traditional values. None of this faffing around in alternate dimensions. Oh no. This is a straightforward lump of heroism in the classic style.

You take the role of Kage, a swordsman and brave warrior. The Princess Kiri has allowed herself to be taken captive by the evil Warlord. Sounds as if she may be a bit low on the grey matter. (The less, the more?) Being one who is keen to right any wrong, you take it upon yourself to rescue Kiri, and smash the Warlord.

Setting off through dense forest,



the castle, you must rescue the princess and make good your escape.

And you could be forgiven for thinking that was the end of the game, but you'd be WRONG! The game takes place during four seasons, each just that little bit tougher than the last. Each time Kage rescues Kiri another season will begin and he'll have to do it all over again!

Streetdate: December  
Price: £7.95



Kage (Japanese name, so pronounce as if you are cross and in pain) finds himself in mortal combat with an assorted bunch of fiendish Ninjas. Climbing the trees, and using his sword-wielding prowess he must battle his way to the second stage - the moat. After swimming through the moat, Kage will encounter castle walls.

As you fight through the different levels, you will encounter all sorts of evil monsters. How do you fancy coming up against a horde of utterly evil wizards?

Finally, as you reach the top of



## LOCH OUT FOR NESS

Terror of the Deep, from Mirrorsoft sounds like a very peculiar little game indeed. It is necessary for you, as a late nineteenth-century explorer's apprentice, to investigate the mysterious happening in Loch Ness.

The great man, your hero, has become ill, and summons you with his dying breath in order to pass on the "terrible responsibility" that his quest entails. Strange things have happened in the Loch. Sailors have vanished without trace, and the locals are getting decidedly miffed.

Placing you in charge of his old, but valuable, submarine he says



# PREVIEW

## PEACE LOVIN' ZYRONEANS IN SF KAYLETH!!

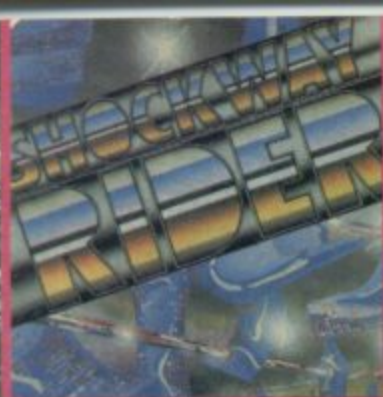

### SHOCKING!

**S**hockway Rider – the follow-up to FTL's hit Lightforce – is a bizarre little game.

The storyline and plot are amazingly simple: you have to ride the moving walkways around a futuristic city, avoiding the obstacles placed in your path.

The object of the game appears to be simply to ride the walkways for as long as possible without falling off.

As well as numerous gangs of youths who roam the walkways, the player must combat the police who are decidedly unpleasant.

The game will feature numerous scrolling windows, used to simulate the walkways' varying speeds. Graphics are pretty whizzy, too, with a large central character.

Looks like a severe case of stick-wiggling will ensue when the game appears.

Streetdate: End of December  
Price: £7.95

**K**ayleth from US Gold is an Adventure. The Zyroneans were a peaceful race until the evil Kayleth arrived and everything went decidedly sour. It is your task, as a loyal Zyronean – Oh God, no. Look, I can't stand any more of this. I thought this job would be really easy and everything but all I get to do is sit at this typewriter talking about advanced civilisations, when you all know that it's completely untrue. (Get on with it – Ed)

Anyway, it materialises that this Kayleth character is a real pain, and you've got to get rid of him. How do you do it? Simple, you type commands into a little black box with rubber keys.



It's possible to type in whole sentences (invert the banana and sharpen it with the branch) and even talk to some of the characters in the game if you feel like it.

Kayleth is programmed by the people who used to be called Adventure International, until US Gold bought them up and called them Adventure Soft. It features some rather natty graphics too.

Apparently, Kayleth has something to do with Assac Asimov. Probably one of his rosey magazine stories. If you're into overthrowing tyrannical overlords with odd names, Kayleth promises to be worth a look.

Streetdate: December.  
Price: £8.99



You are outside the ancient citadel of Zenron. A troop of ferocious Zemps circle around you!

## ROCKMAN GRABS THE GRAIL

**D**a-daaa! Here's Rockman! The latest game from Alligata features the best-looking macho hero ever found in a computer game. Well, this is what they would have you believe. As a matter of fact, he has the most useless grin, and some truly horrific clothes.

Anyway, moving swiftly away from all this tosh, Rockman – for it is he! – is happy and contented sort of bloke, until he is called to the King of Spain's bungalow, and informed that a really bad thing happened the other day. "The Holy

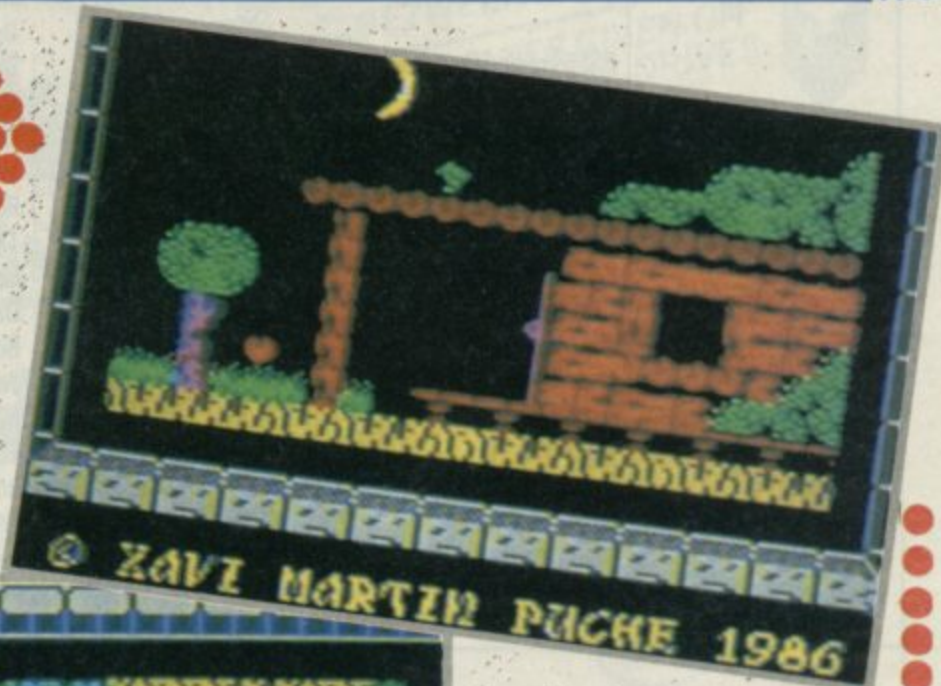

Grail has been nicked," said Kingy, "and we're in a right old state. Get on yer bike and get it back from that loony in the hills."

"OK," said Rockman.

Rockman will have to use all of the knowledge gleaned from the old man to recover the Grail. (There's always an old man in these things. You know, the sort of guy with puffy eyes who can't speak well, but is really clever.)

Rockman is a graphic adventure (don't ya just know it) featuring big graphics and lots of colourful things to jump about with.

Streetdate: early January.  
Price £2.99



that it's your duty to explore the Loch and discover the enormous creatures which, it has been rumoured, live there.

The game looks vaguely like RMS Titanic. The screen is presented like the inside of the submarine, with a view of the outside world, moving around in 3D. Various dials and gauges move on the display, indicating all the important controls.

In case of an attack from unpleasant underwater monsters, you are armed with a harpoon gun, with which you can prang any aquatic life-form in view.

As depicted, the game looks pretty ruddy murky, which means that it will probably be a big success. (?-Ed)

Streetdate: March  
Price: £7.95





# THE SINCLAIR COMPUTER CLUB



- ★ **Exclusive Members Only Offers**
- ★ **Free Monthly Magazine worth £11.40**
- ★ **Special Member Discounts**
- ★ **Club Newsletter that you can contribute to**
- ★ **Club Meetings in your own area**
- ★ **Competitions - Profit from your skill**



## YOU'VE READ THE REVIEWS - HERE ARE THE GAMES

	List Price	Our Price	Our Members Price		Ace	£9.95	£9.00	<input type="checkbox"/>	£8.45	<input type="checkbox"/>
PSI-5 Trading Company	£7.95	£7.15	<input type="checkbox"/> £6.35	<input type="checkbox"/>	Dynamite Dan II	£7.95	£7.15	<input type="checkbox"/>	£6.35	<input type="checkbox"/>
Shaolins Road	£7.95	£7.15	<input type="checkbox"/> £6.35	<input type="checkbox"/>	Dan Dare	£9.95	£9.00	<input type="checkbox"/>	£8.45	<input type="checkbox"/>
Uridium	£8.95	£8.15	<input type="checkbox"/> £7.20	<input type="checkbox"/>	Heart Land	£9.95	£9.00	<input type="checkbox"/>	£8.45	<input type="checkbox"/>
Dragon's Lair	£7.95	£7.15	<input type="checkbox"/> £6.35	<input type="checkbox"/>	Crash Smashes II	£9.95	£8.95	<input type="checkbox"/>	£8.45	<input type="checkbox"/>
Asterix	£8.95	£8.00	<input type="checkbox"/> £7.20	<input type="checkbox"/>	Vera Cruz	£8.95	£8.10	<input type="checkbox"/>	£7.60	<input type="checkbox"/>
Elite	£14.95	£13.45	<input type="checkbox"/> £11.70	<input type="checkbox"/>	Revolution	£8.95	£8.15	<input type="checkbox"/>	£7.20	<input type="checkbox"/>
Strike Force Harrier	£9.95	£9.00	<input type="checkbox"/> £8.45	<input type="checkbox"/>	They Sold A Million III	£9.95	£9.00	<input type="checkbox"/>	£8.45	<input type="checkbox"/>
Silent Service	£9.95	£9.00	<input type="checkbox"/> £8.45	<input type="checkbox"/>	Scooby Doo	£7.95	£7.15	<input type="checkbox"/>	£6.35	<input type="checkbox"/>
1942	£7.95	£7.15	<input type="checkbox"/> £6.35	<input type="checkbox"/>	Dandy	£7.99	£7.15	<input type="checkbox"/>	£6.35	<input type="checkbox"/>
Frost Bite	£8.95	£8.15	<input type="checkbox"/> £7.20	<input type="checkbox"/>	Bobby Bear	£7.95	£7.15	<input type="checkbox"/>	£6.35	<input type="checkbox"/>
Great Escape	£7.95	£7.15	<input type="checkbox"/> £6.35	<input type="checkbox"/>	Jewel Of Darkness	£14.95	£13.45	<input type="checkbox"/>	£11.95	<input type="checkbox"/>
TT Racer	£9.95	£9.00	<input type="checkbox"/> £8.45	<input type="checkbox"/>	Napoleon At War	£8.95	£8.00	<input type="checkbox"/>	£7.20	<input type="checkbox"/>
Paper Boy	£7.95	£7.15	<input type="checkbox"/> £6.35	<input type="checkbox"/>	Theatre Europe	£9.95	£9.00	<input type="checkbox"/>	£8.45	<input type="checkbox"/>
Light Force	£7.95	£7.15	<input type="checkbox"/> £6.35	<input type="checkbox"/>	Infiltrator	£9.95	£9.00	<input type="checkbox"/>	£8.45	<input type="checkbox"/>
Nightmare Rally	£7.95	£7.15	<input type="checkbox"/> £6.35	<input type="checkbox"/>	Hardball	£8.95	£8.15	<input type="checkbox"/>	£7.20	<input type="checkbox"/>
					A years club membership with 12 free Magazines	£14.95		<input type="checkbox"/>		<input type="checkbox"/>

To join simply complete the box opposite and post it to:

SINCLAIR COMPUTER CLUB  
P.O. Box 52  
Sunderland  
Tyne & Wear SR1 3QE

OR Phone the Order Action Line 0783 658116

ACCESS

VISA



Please send me details of the Sinclair Computer Club

I would like to join the Sinclair Computer Club, I have chosen the games marked above.

\_\_\_\_\_

\_\_\_\_\_

\_\_\_\_\_

\_\_\_\_\_

\_\_\_\_\_

POSTCODE \_\_\_\_\_

My Visa/Access No. is \_\_\_\_\_

I enclose my cheque for £ \_\_\_\_\_ Games

My computer is \_\_\_\_\_

SUD

SPECTRUM · BBC · COMMODORE · AMSTRAD · APPLE · IBM PC  
PRINTERS · EPSON · SEIKOSHA · MOST MAKES OF DISK DRIVES

# EXPRESS

COMPARE OUR GUARANTEE  
TERMS – YOU DON'T FIND  
ANY 'HIDDEN CATCHES'  
AFTER THE REPAIR!

WHY PAY HIGH  
"FIXED" PRICES?

# REPAIRS

OUR PRICES INCLUDE VAT, P&P AND INSURED DELIVERY!

MANCOMP SETS THE STANDARDS AND  
PRICES – OTHERS FOLLOW!

WHEN WE SAY 'NO HIDDEN COSTS'  
WE MEAN IT!

## NO HIDDEN EXTRAS

THE FIRST AND STILL THE BEST.

**FIRST –**

To provide 'While-U-Wait' Service.

**FIRST –**

With International repairs and discounts for Schools, Hospitals and H.M. Forces.

**FIRST –**

To provide Insured/Recorded Delivery on return journey.

**FIRST –**

With **LOW CHARGES** (e.g. £9 for keyboard faults).

**FIRST –**

For **PROFESSIONALISM**... "Of all the repair companies 'Sinclair User' spoke to, **MANCOMP** seemed the most professional when it came to advice and a helpful attitude". AUGUST 1985.

**FIRST –**

For **SPEED**... "One firm, at least, can usually effect any necessary repair 'over-the-counter' in 45 mins. Based in Manchester, **MANCOMP** can offer what is arguably the fastest turnaround in the business, to personal callers". 'CRASH' Magazine, JUNE 1985.

**FIRST –**

For **ADVICE & HELP**... "I have come across a firm that will be more than willing to advise you as to how to remedy your problem. They are called **MANCOMP** and as well as repairing faulty Spectrums, are also quite willing to discuss your problems with you, and offer reasonably cheap and (more importantly) **CORRECT** cures". Phil Rogers, 'POPULAR COMPUTING WEEKLY', JANUARY 1985.

**FIRST –**

For **LOW PRICES**... "My Spectrum blew recently. I took it to **MANCOMP**, who fixed it in 8 mins. and for less than £10. they are local, 'clued-up', and blindingly efficient!" COMPUTER COLUMN, '4 HEATONS DIGEST', (Vol. 1, No. 11.).

**FIRST –**

For **HONESTY**... Call in and watch your computer being tested and repaired 'While-U-Wait'. Our engineers don't disappear into a back room. If there is nothing wrong, we will tell you!

**FIRST –**

For **REPUTATION**... We have a reputation built on 2½ years of successful Spectrum, BBC, Commodore, Apple and IBM repairs.

SPECTRUM REPAIRS  
BETWEEN £9 and £20

COMMODORE  
REPAIRS BETWEEN  
£14 and £35

BBC REPAIRS  
BETWEEN £14 and £45

AMSTRAD REPAIRS  
BETWEEN £14 and £55

ESTIMATES GIVEN ON  
PRINTERS/DISK DRIVES  
ETC.

(Terms and conditions available on request.)

### MANCOMP GUARANTEE

IF THE SAME FAULT  
OCCURS WITHIN 90 DAYS  
OF OUR REPAIR, WE WILL  
REPAIR IT **FREE** OF  
CHARGE AND REFUND  
THE POSTAGE.  
(TERMS AND CONDITIONS AVAILABLE  
ON REQUEST.)

	MANCOMP PRICE
<b>JOYSTICKS</b>	
PRO JOYSTICK	16.50
QUICKSHOT II	9.50
<b>INTERFACES</b>	
TRISTATE I/F.	12.50
PRO JOYSTICK I/F.	16.50
RAM TURBO I/F.	17.99
STD. JOYSTICK I/F.	7.50
SWITCHABLE	9.50
J/S. I/F. & THRO CONNECT	12.40
MULTIFACE 1	38.50
CENTRONICS E I/F.	38.50
DISC I/F.	80.00
KEMPSTON MOUSE I/F.	64.50
PARALLEL PRINTER I/F.	28.50
AMX MOUSE	65.00
RGB I/F.	35.00
<b>TASMAN</b>	
TASWORD 3	16.50
TASWORD 2	12.99
TASMERGE	10.50
TASPRINT	9.50
TASDIARY	8.99
TASWIDE	5.00
TASCOPY	9.50
MEGA SOUND	10.50
SWEET TALKER	22.15
RAT	18.99
SPECTRUM	28.50

**FREE  
GAMES  
WORTH £39  
(WITH EVERY SPECTRUM  
REPAIR)**

WE ARE  
MOVING.  
CHECK  
FOR  
DETAILS

PHONE OR SEND  
YOUR COMPUTER (without  
power supply or leads) FOR  
FREE, NO OBLIGATION  
ESTIMATE!

## MANCOMP LTD.,

(Dept. SU1)

PRINTWORKS LANE, LEVENSHULME,  
MANCHESTER M19 3JP.

Tel: 061-224 1888/9888

OPEN  
MON-SAT  
9AM-8PM

48K SPECTRUM UPGRADE  
£18 FITTED  
THE BEST KEYBOARD FOR  
YOUR SPECTRUM –  
THE SAGA I EMPEROR –  
£39.95 INCLUSIVE!

**MONITORS**

STD. RES. M'VITEC RGB	201.50
PHILIPS GREEN BM7502	79.00
PHILIPS COLOUR CM8501	209.95

**DISKETTES**

BOX OF TEN INCL. FREE LIBRARY CASE	10.95
---------------------------------------	-------

**LISTING PAPER**

60 g.s.m. 11" x 9½" (2000)	13.00
-------------------------------	-------

**PRINTER RIBBONS**

PLEASE PHONE  
ALL PRICES INCLUDE  
VAT/CARR. EXTRA.

ROBOTEK	28.50
LIGHT PEN & I/F.	18.99
CURRAH SPEECH	19.50
CURRAH MICROSLOT	6.50
WAFADRIVE DISC SYS.	120.00
ROTRONICS 128K WAF	3.50
ROTRONICS 64K WAF	3.35
ROTRONICS 16K WAF	3.25
MICRODRIVE CARTRIDGE	1.99
RS232 CABLE FOR I/F. 1	13.99
<b>PRINTERS</b>	
EPSON FX804	442.75
EPSON LX80	225.00
JUKI 6100	350.00
BROTHER HR10	274.85
BROTHER M1009	149.00
<b>DISK DRIVES</b>	
OPUS DISCOVERY 1	149.50

SOFTWARE & ORDERS ABOVE £5.00 add £1.80 P&P  
SOFTWARE ORDERS BELOW £5.00 add 50p P&P.

WE REPAIR HUNDREDS OF  
COMPUTERS EVERY WEEK, SO WE  
CAN PASS ON OUR BULK-BUYING  
DISCOUNTS TO YOU – Z80 CPU –  
£1.50, 4116 RAM – £0.50.  
COMMODORE CHIPS: 906114 – £23,  
6526 – £23, 6510 – £23 (INCLUSIVE  
OF VAT & P&P).

# PREVIEW

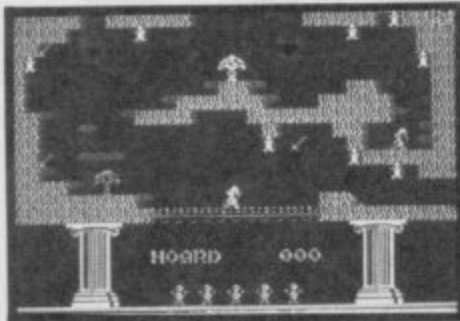

## REALLY ALTERNATIVE

**H**urrah! A tad of sensibility has just appeared in the shape of two budget games from Alternative Software. . .

Henry's Hoard is a straightforward platforms and ladders game involving Henry, fifty locations, 200 items to collect and stacks of traps.

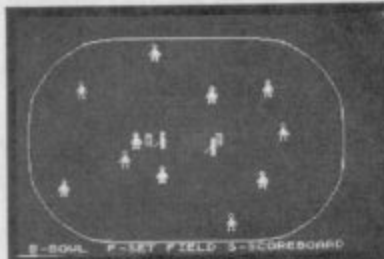

Howzat is a cricket game with graphics, bowling option, field changes, name changes, skill factors, scoreboards and match analysis.

Each game costs under £2 so you can't really go wrong.  
Streetdate: December/January.  
Price £1.99

## WHAT IS IT GOOD FOR?

**W**argames are still astoundingly popular. PSS has just released two titles based on the mutilation and destruction of other human beings. Not being the sort of mag to take a political stance on such matters, **SU** is quite happy to preview the games.

The first is *Annals of Rome*, and is based upon the struggle of the Roman Empire to achieve world supremacy. The game should be a delight for wargamers and megalomaniacs alike, featuring things such as "fiscak problems" and a "phase game".

*Battlefield Germany* is more straightforward. The commies are invading West Germany, and it's up to you to stop them. The game features a nuclear option, which has presumably a similar effect to the Quit option in similar programs. An interesting feature is that it is possible to take the role of the Warsaw Pact, and attempt to overrun the den of capitalist hypocrisy in one fell swoop, introducing the world to the wonders of communism.

The games are based on the familiar wargaming foundations, and provide a couple more wars to wage with your Spectrum.

Streetdate: November (both)  
Price: £12.95 (each)

*Annals of Rome*  
Price: £12.95

Streetdate: November.

## WAR WALLY

**T**he thunder of an exploding CS cannister, the smell of noxious gas in your nostrils, the flare from the muzzle of an Heckler + Koch 9mm. It's all go as a member of the SAS. Up and down those ropes all ruddy evening, and zooming about in those brilliant helicopters. It's Mikro-Gen's latest, SAS Strikeforce.

A very nice man in a Milk Tray advert costume swung into the Preview Suite at **SU** towers, with a copy of the game which has been on Mikro-Gen's lips for ages. The idea is to carry out a house clearance, using bombs and guns, and get rid of some of those undesirables who occupy various locations throughout the game.

Apparently, the program was developed with the co-operation of the "lads", and we reckon it could be one of the big sellers of the coming months. The only problem is that the screen does bear stunning similarities to other Mikro-Gen games.

Wally Goes to War?  
Streetdate: December.  
Price £7.95

## SCOOPER!

**D**um dum dum diddle-de dum dum dum. . . From the ranks of the super-killers comes a man stronger than any other, tougher than any other, rougher than any other.

The year is 2108. On a distant planet, the inhabitants of a solar system struggle to negotiate a peace-treaty. Everyone knows that this is their last chance.

You are Trooper. The man leading the Earth delegation. After uncovering a plot to scupper the negotiations, you learn of the aliens' plans for over-throwing the universe by controlling helpless minds. . .

Deary me, readers. They Call Me Trooper is a 128K game from CRL featuring very little indeed except a small man legging around in service boots, climbing the occasional rope and getting into large-character-graphics fights with anyone who pops out of the



alien landscape.

"There is one priority in your mind," burlies the useless introduction, "escape from planet Therop ALIVE!"

Trooper looks a cross between Jet Set Willy and a karate game.  
Streetdate: December.  
Price: £8.95

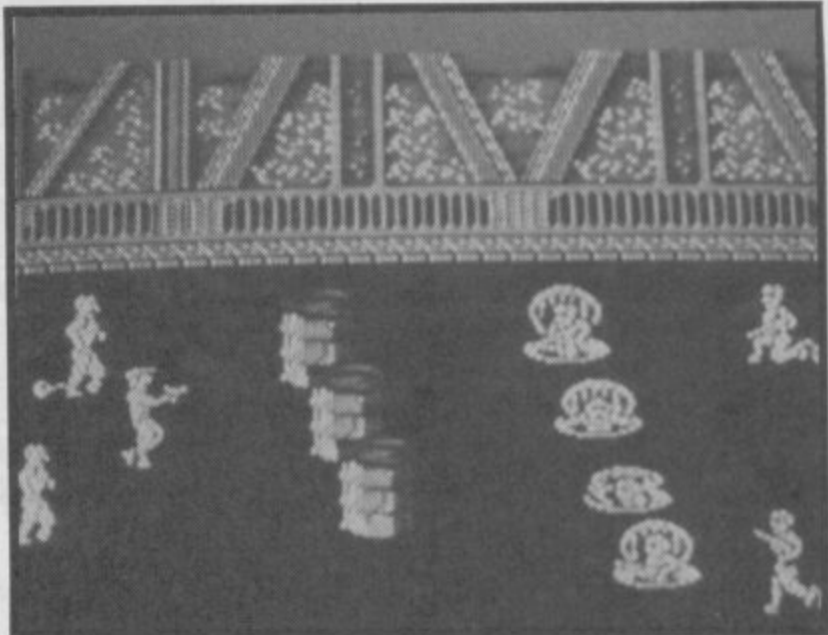

## KONAMI DRIVE

**T**his is Konami Jailbreak screen shot. The firm promises us that the game is 'nearly ready' and it has been inundated by people calling trying to find out when it

will appear. It doesn't look too bad, in fact.  
Revised Streetdate: really soon, honest.  
Price: £7.95

## STUDIO OF THE FUTURE

**A**dvanced Art Studio is for the 128K + 2 only, and comes from Rainbird.

The program is really, really clever and can do lots of very useful things like, um. . . well. . . you could use the Ramdisc feature, and make the program remember what you were doing without saving it or. . . er. . . create a scrapbook with lots of family photos or something. . .

(Computer Art Buff interrupts: In fact, the Scrapbook is a genuinely interesting feature, allowing the user to select a certain section of the screen, and then move that area to a different 'page'. The process can be repeated allowing the more useful blocks of the screen to be stored in a small space, and then re-created at will.)

You can also use the completely brilliant Font Editor, where you can create those completely fantastic (if illegible) text fonts and put them on your art stuff. Pretty cool, huh?

The Fill routine is better now, too. You can design your own pattern and when you hit that button whoosh! There's an Arc feature. The world would be pretty straight without curves, right? Well, you can do lots of real crazy

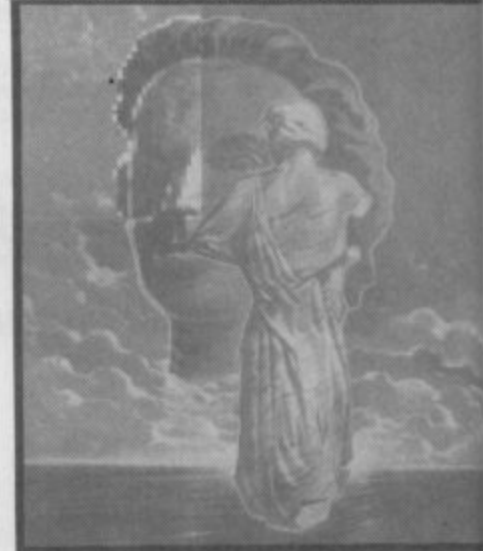

stuff and, like, bend things too.

(Art buff again - by fixing two points, designating the start and end of the arc, and a third showing the extent of curvature, the program will construct the desired curve.)

All of the features in the original program are included, too.  
Streetdate: December.  
Price: £24.95

## CHECK OUT THE FAX

**Z**arjaz it may be, but the style is very much **SU**.

This is the latest press release from those astoundingly pleasant people at Ariolasoft. While you're

reading, take note of the intriguing text style found in preposterously large quantities in the pages of **SU**. What does this mean? Search me.

## FAX McSHEEN BLASTS HIS WAY THROUGH SPACE . . .

A distant future date . . . a Zone of space is discovered not obeying the normal laws of the Universe (tuti). The entrance to the Zone leads out of our universe and into a weird cone-shaped area of space.

Our hero, Fax McSheen (you), is despatched from Astro College to investigate in a large flying saucer with rocketty things on the back (who wrote this garbage? - Ed). He is accompanied by three attack Drones which he soon realises can only be controlled by him if he keeps them in sight (errant children need tape on backside etc. etc.). Unfortunately for the lazy Fax, this means following the Drones into the Zone and destroying planets and other 'bodies' that get in his way.

CONTINUED NEXT WEEK . . . FOR BUBBLES!

COMPILED BY JIM DOUGLAS

# 24 HOUR

# COMPUTER REPAIRS

and

## AMSTRAD · SINCLAIR

QUALITY APPROVED REPAIR CENTRE

## COMPUTER SPARES



### HOW TO GET YOUR SPECTRUM REPAIRED FOR ONLY £19.95

THE NO. 1 REPAIR CENTRE IN THE U.K. OTHERS FOLLOW

SPECTRUM (only) KEYBOARD REPAIRS £8.95 THE CHEAPEST AROUND

WHILE YOU WAIT SERVICE CALL FOR APPOINTMENT

MANCHESTER CITY CENTRE BRANCH NOW OPEN. CALL FOR DETAILS

WHY NOT COME AND VISIT US AT OUR NEW 2,500 SQ. FT. WORKSHOP. YOU CAN EVEN HAVE A CUP OF COFFEE WHILE YOU WAIT.

### SPECIAL OFFER!

Why not upgrade your ordinary Spectrum into the fantastic DK Tronics typewriter keyboard for only **£31.50** including fitting, VAT and return post and packing. Normal recommended retail price **£49.95**. Replacement printed DK Tronics key sets **£7.50** including post & packing.



### SPECIAL OFFER!

Why not upgrade your 16K Spectrum to a 48K for as little as **£17.95** including VAT, post and packing. If you would like us to fit the kit for you, just send us **£19.95** which is a fully inclusive price to cover all costs including return postage. Full fitting instructions supplied with every kit. Issue 2 and 3 only.



### Update Your Rubber Keyboard to a New Spectrum+

Fitted for only **£29.95 + £1.50** post & packing. (Also D.I.Y. Kit available for only **£23.00 + £1.50 p & p**) Same day service LIMITED OFFER



## TEN ★ REPAIR SERVICE

- ★ While you wait service including computer spare parts over the counter.
- ★ All computers fully overhauled and fully tested before return.
- ★ Fully insured for the return journey.
- ★ Fixed low price of £19.95 including post, packing and VAT. (Not a between price of really up to £30.00 which some of our competitors are quoting).
- ★ Discounts for schools and colleges.
- ★ Five top games worth **£33.00** for you to enjoy and play with every Spectrum repair.
- ★ We repair Commodore 64's, Vic 20's, Commodore 16's and Plus 4's.
- ★ The most up to date test equipment developed by us to fully test and find all faults within your computer.
- ★ Keyboard repairs, Spectrum rubber key boards only **£8.95**.
- ★ 3 month written guarantee on all repairs.

**BEST SERVICE - BEST PRICES!**

### ARE YOU ANOTHER CUSTOMER - fed up waiting weeks for your estimate?

Need your computer repaired fast? Then send it now to the Number One Repair Company in the U.K., or call in and see us at our fully equipped 2,500 square foot workshop, with all the latest test equipment available. You are more than welcome. We will repair your computer while you wait and help you with any of your technical problems. Commodore computers repaired for only **£35.00**. Please note we give you a 100% low fixed price of **£19.95** which includes return post and packing, VAT, not a between price like some other Repair Companies offer. We don't ask you to send a cheque in for the maximum amount and shock you with repair bills **£30** upwards. Don't forget we are Amstrad approved for quality and speed, don't risk your computer to any other unauthorised repair centre. We don't just repair the fault and send your computer back, we give your computer a:-

### FREE OVERHAUL WITH EVERY REPAIR WE DO:-

We correct colour, sound, keyboard, check the loading and saving chip, put new feet on the base if required, check for full memory, check all sockets including ear/mike and replace where needed. All for an inclusive price of **£19.95** including VAT, all parts, insurance and post and packing. No hidden extras whatsoever. We don't have to boast too much about our service as we have thousands of customers from all over the world highly delighted with our service. A first class reputation for speed and accuracy. Don't forget, we also now have a Service Branch in Manchester City Centre for while you wait service.

### EXTENSION RIBBON



56 Way ribbon cable to extend your ports for your peripherals **£10.95** plus **£1.50 p & p**



KEYBOARD TEMPLATES **£5.50** plus **£1.50 p & p**



RUBBER MAT **£6.50** plus **£1.50 p & p**

### REPLACEMENT POWER SUPPLY



Spectrum replacement power transformer suitable for all makes of computer **£9.95** plus **£1.50 p & p**



NEW SPECIAL OFFER! Gun Shot II Rapid Fire Joystick and interface complete outfit. Normal recommended retail price **£19.95** if purchased together. Special offer of only **£16.50** including p & p. Joystick available as separate item **£10.95** plus interface available as separate item **£9.00** plus **£1.50 p & p**

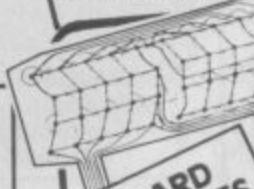

Spectrum keyboard membranes **£5.50** plus **£1.50 p & p**

### COMMODORE POWER SUPPLY



Commodore replacement power transformer **£29.00** plus **£1.50 p & p**

### KEYBOARD MEMBRANES

Spectrum Plus spare keyboard membranes **£12.90** plus **£1.50 p & p**  
ZX 81 membranes **£5.00** plus **£1.50 p & p**

### VideoVault

### D.I.Y. CORNER

We regret we cannot show all the components available. Just give us a call and we can quote you over the phone, delivery by 1st class post.

SPECTRUM SPARES		COMMODORE SPARES	
280B CPU	3.00	6526 - C.I.A.	19.00
4116 Rams	1.00	6510 - Processor	19.00
ZTX 650	0.60	6581 - Sid Chip	19.00
ZTX 213	0.60	906114 - House Keeper	19.00
Power Supply Transformers	9.95	901225 - Graphic Rom	19.00
ULA 6C001	16.50	901226 - Basic Rom	19.00
Rom	16.50	901227 - Kernal Rom	19.00
Keyboard membrane Spectrum	5.50	6569 - VIC	19.00
Keyboard membrane Spectrum Plus membrane	12.90	4164 Rams - Memory	3.00
Metal Templates	5.50	Power Supply Transformers	29.00
Keyboard Mats	5.50		
ZX81 membrane	5.00		
Service Manual	£30.00		

VIDEOVAULT HEALTH WARNING!!! Sending your computer to any other Repair Centre can seriously Damage its Health

# VideoVault Ltd.

140 High Street West, Glossop, Derbyshire SK13 8HJ  
Tel: 04574-66555/67761 Head office & access orders, queries, Manchester 061- 236 0376 while you wait repair centre only.

FULLY REPAIRED AND TESTED ON MOST ADVANCED TEST EQUIPMENT IN EUROPE!

OPEN 7 DAYS A WEEK MANCHESTER MON-SAT ONLY

ORDER NOW!

SPECIAL OFFER

5 GREAT FREE GAMES  
NORMAL RECOMMENDED RETAIL PRICE  
YOURS FREE WITH EVERY SPECTRUM REPAIR  
**£39.00**

# SINCLAIR user

## SUPERMART

TO ADVERTISE IN THE SUPERMART  
PLEASE CALL JACQUI POPE ON 01-251 6222

### COMPUTER SPARES

SINCLAIR/AMSTRAD  
/COMMODORE

ROM CHIPS	CMOS CHIPS
RAM CHIPS	74LS CHIPS
ULA'S	VOLT REGS
MEMBRANES	Z80 CPU
POWER SUPPLY'S	DFS KITS
TEMPLATES	EPROMS
MODULATORS	SERVICE MANS
SPEAKERS	TRANSISTORS
RIBBONS	TUBES
DISC'S	KEYBOARDS

TRADE COUNTER OPEN  
MON-SAT 9.30a.m.-5p.m.

Just phone  
your order  
through, we  
do the rest



Order from Govt. Institutions,  
Schools, Nationals etc.,  
accepted with official order.

TEL: 0254 390936

P.V. TUBES  
104 ABBEY ST.  
ACCRINGTON LANC'S  
BB5 1EE  
Telex: 635562  
Griffin G (For P.V.)

### SPECTRUM REPAIRS

Spectrum repairs £18.95 including  
parts insurance and P/P.

Send your computer with cheque or PO  
for £18.95 and description of the fault to:

**SUREDATA (SU)**  
45 Wychwood Avenue,  
Edgware, Middlesex.  
Tel: 01-951 0124

### NEW TAPE UTILITY 9

This program gives a tape back-up of most software! Even converts most jerky loaders to normal for reliable loading. Manages v. long programs (even 51k!), fast loaders, etc., etc., 48k Spectrums only. **£6.99 on tape (£4.99 if updating).**

### NEW TRANSFER PACK 3 — FOR TAPE TO DRIVE

A software system to convert many TAPE based programs to your DRIVE (not matter what type) + OTHER USEFUL utilities. Most jerky loaders are EASILY converted to drive. Pack has at least 7 programs! Only 48k Spectrums. Opus/Beta owners add £1 for optional extra program.

State name of your drive when ordering. **£11.99 on tape OR £12.99 on m/drive cartridge.** (£6 if updating)

INFORMATION SHEETS — £1 each — approx 8 transfers of popular programs, per sheet — needs TP3. Up to No. 25 available. **Special offer — No's 1 to 20 only £4.50!**

MICROTRANS — for m/drive to m/drive back-up + tape to m/drive (incl headerless) — does NOT covert programs. **£3 on tape, £4 on m/drive cartridge.**

Overseas: add £1 Europe, £2 others each product. SAE for enquiries.

**ALL OUR PROGRAMS CARRY OUR MONEY BACK GUARANTEE**  
(not updates)

LERM, DEPT SU, 11 BEACONFIELD CLOSE, WHITLEY BAY NE25 9UW  
(Tel: 091 2533615)

Please send now for our  
extensive catalogue of Spectrum  
Software for hire, with over 250  
music tapes available as well.  
£2 membership (refundable if  
not satisfied)

SOUNDBOX SOFTWARE DEPT SU  
P.O. BOX 12, RENFREW  
RENFREWSHIRE, SCOTLAND PA4

### SPECTRUM REPAIRS

We expertly repair Spectrums  
for £17 inclusive of parts and  
labour and return postage.

Spectrums upgraded to 48K  
for £34 inc. P&P. All keyboard  
faults cost only £12.

RA ELECTRONICS  
133 London Road South  
Lowestoft, Suffolk  
Tel: (0502) 66289

### TANGLEWOOD SOFTWARE

157 Warwick Road, Rayleigh,  
Essex SS6 8SG

#### THE RACING GAME

All the thrills of managing  
your own stable of  
thoroughbreds  
TRAIN,  
SELECT,  
BET,  
Watch them race  
SO LIKE THE  
REAL THING



£6.95

#### FOOTBALL FEVER

Manage your team to win  
THE LEAGUE TITLE  
CUP WINNERS CUP  
EUROPEAN CUP  
F.A.CUP  
Features include:  
Team selection, injuries,  
substitutes, bookings,  
suspension etc.etc.  
Take the challenge



£6.95

Both Games for £11.90  
for Spectrum 48K and 128K+2



### KIDDISOFT

IS BACK!  
COMPUMAG FOR  
4 to 8 yrs.  
48k SPECTRUM  
£3.99

KIDDISOFT,  
5 Nanpusker Road  
Hayle, Cornwall

AT LAST THE REAL McCOY



### FOOTBALL DIRECTOR



ONLY AVAILABE ON SPECTRUM 48K OR +  
FOUR LEAGUES: 20 TEAMS EACH: 38 GAME SEASON: HOME + AWAY: FA/  
LEAGUE CUPS: REPLAYS: EUROPEAN/U.E.F.A.CUP WINNERS CUP: 2 LEGS:  
AGGREGATE: PENALTIES: PLAYERS: MORALE: SKILL:FIELD POSITION:  
SCORED: CONCEDED: PLAYED: FIXTURE LIST: PWD/FAPts: SCOUTS: COACH:  
PHYSIO: YOUTH TEAM: GAMBLE: SUBSTITUTIONS: SENDING OFFS:  
POSTPONMENTS: MIDWEEK GAMES: MORE THAN 1 WEEK INJURIES: FREE  
TRANSFERS: RETIREMENTS: BUY/SELL SHARES: 3 PLAYER TRANSFER  
MARKET: INTERNATIONALS: EUROPEAN TOURS: 3 LEVELS: MANAGER RATES:  
£1,000,000 PLAYERS: PRINTER OPTION: 8 RESERVES: PROMOTION:  
RELEGATION: WEEKLY NEWS: BORROWING: MORTGAGE: SAVE GAME:  
INTEREST: TAX: SPONSORS: FULL RESULTS: SEASON TICKETS: NEXT GAME:  
GATE MONEY: SEASON COUNTER: TV CAMERAS: CROWD VIOLENCE:  
MANAGER APPROACHES: TESTIMONIALS: WEEK'S PROFIT: LMTG COUNTER:  
WAGES: INTERNATIONAL COMMITMENTS: NAME/TEAM EDITOR: LEAGUE  
TITLES + MUCH MORE

### 2 PLAYER SUPER LEAGUE

MANY OF THE ABOVE FEATURES BUT 2 TEAMS CAN PLAY IN THE SAME OR  
DIFFERENT DIVISIONS: INCLUDES LOCAL DERBYS: LOAN/FREE TRANSFER +  
CASH SETTLEMENTS: INCREASED TRANSFER MARKETS: MANAGER OF THE  
MONTH AND TOP SCORER LEAGUE

### INTERNATIONAL MANAGER

QUALIFYING GROUPS: WORLD CUP: EUROPEAN CUP: TOURS: BOOK YOUR  
FIXTURES: FRIENDLIES: HOME + AWAY: MATCH REPORTS: SUBSTITUTION:  
NEXT FIXTURE: PLAYERS: MORAL: FORM: TALENT: CONSISTENCY: CAPS: AGE:  
AVAILABILITY: SUSPENSION: INJURIES: RETIREMENTS: SCORED: WORLD  
RANKING: SEASON COUNTER: EXTRA TIME: PENALTIES: SAVE GAME AND  
PRINTER OPTION: BOOKINGS: SENDING OFFS + MUCH MORE

### RECORDS FILE

COMPATIBLE WITH ALMOST ANY  
LEAGUE TABLE: ESPECIALLY  
DESIGNED FOR FOOTBALL  
DIRECTOR & 2 PLAYER SUPER LEAGUE: ENTER YOUR END OF  
SEASON DATE AND IT WORKS OUT: BEST TEAMS: TEAMS AVERAGES:  
RECORDS: TITLE WINS: HOW MANY SEASONS PLAYED AND OTHER  
INFORMATION (This is not a game)

### PLAYING TIPS

ALL THE TIPS YOU NEED TO WIN AT  
EITHER FOOTBALL DIRECTOR, 2  
PLAYER SUPER LEAGUE OR  
INTERNATIONAL MANAGER **£1.00**

**EACH GAME £4.99 ANY TWO £9.50  
ANY THREE £14.00 ALL FOUR £18.25**  
Enclose Cheque/PO + Large SAE with 20p stamp  
attached per cassette

### D & H GAMES

19, MELNE RD, STEVENAGE, HERTS, SG2 8LL  
MAKES THE OTHERS LOOK LIKE THE SUNDAY  
LEAGUE

## POOLS PREDICTION

Perfect over 6 seasons. Outputs best draws, homes & aways. Holds form comparison graphs. Analyses & graphs results. Takes full account of mid week games & "Cup" matches between main league teams. Promotion/relegation option (can be used from season to season). Easy to use, even for beginners. 62 wins (365 dividends) received by author so far. "The best and most scientific of any program I have seen" — Mr R.A.P. Secretary Orpington Computer Club. "once again, thank you for one of the best investments I have made" — Mr D.L.B. Feltham. "I would like to congratulate you on your excellent service. It is a rare thing these days" — Mr L.G.P. Shrewsbury. "I found your program very professional and user friendly, I am very satisfied with it" — Mr B.D. Spalding.

Ask for British Pools @ £11.95  
Australian Pools @ £11.95  
Allow 7 days for delivery. Cheques, POs payable to ROMBEST or quote Access card number.  
Rombest Dept SU, 2 Welland Croft, Bicester, Oxon OX6 8GD (0869) 248002  
Available for 48K Spectrum

## CASH FROM YOUR MICRO

Use your computer to make money. Turn your hobby into a home-based income. Full and part time opportunity to cash in on this tremendous market. High earnings easily possible. Open to an amateur micro user and gamer. Write for free details.

**Westlink Promotions C.D.**  
108 George Street, Edinburgh EH2 4LH

## HINTS · POKES · MAPS

"Stunning value" — Tony Bridge, Popular Computing Weekly  
The monthly handbooks packed with tips, pokes, hints, maps, solutions, gossip, latest reviews, competitions and much more

**ADVENTURERS HANDBOOK** (CBM/Spec) £1.00  
**SPECTRUM ARCADE HANDBOOK** (48/128) £1.00  
or for even better value take advantage of our reduced subscription rates 3 issues £2.75; 6 issues £5.00; 12 issues £9.00. Send cheque or P.O. to

**H & D SERVICES (SU),**  
1338 ASHTON OLD ROAD  
HIGHER OPENSHAW  
MANCHESTER M11 1JG  
Tel 061 370 5666

RGB OUTPUT ?  
COMPOSITE VIDEO ?  
GREEN SCREEN ?  
TTL - ANALOGUE ?  
COMP SYNC ?  
BRIGHT ?  
**adapt electronics**

## CONFUSING ISN'T IT?

Talk to the problem solvers. We have the experience and expertise to advise on all aspects of computer display problems. eg:

★ **RGB OUTPUT MODULE** for Spectrum 16 or 48K. Much acclaimed — gives monitor quality pictures — no dot crawl. **£36.95**

★ **NEW ★ BRIGHT BOX** — Allows full use of the bright facility on analogue input monitors and monitor-TV's to produce full colour palette. Only for Spectrum 128. **£29.95**

Add P&P £1 (UK), £2 (EEC), £4 (Others)  
Send SAE for our Free Monitor Fact Sheet

20 STARLING CLOSE, BUCKHURST HILL, ESSEX IG9 5TN. Tel: 01-504 2640

## TURBO TIPS

The tips and pokes mag for the Spectrum. Loads of tips, maps and pokes plus news, reviews and previews and much more.

Send 75p for issue four to:

**TURBO TIPS,**  
6 Sterndale Road, Romiley,  
Stockport, Cheshire

## ELITE EDITOR

Redefine status, rating, fuel, cargo, weapons, credits, galaxy, special missions, even cloaking device and E.C.M. Jammer, alter every feature for only £1.99.

## ASTROCADE The Collection

**C+VG (July)** "Fancy a Bit of Arcade Fun for £4.50? Then ASTROCADE on the Spectrum from D.D.S. Software could be for you. The six games on offer are Simon, Caverns D'Or, Bomber, Zombies Luna-Rover and Alien."

**Your Sinclair (July)** "They are all very playable. The graphics are adequate, the sound excellent". Addictiveness 7/10; Playability 8/10; Value for money 8/10.

**CRASH (June)** "Overall the ASTROCADE Collection should keep any games player quiet..."

**P.C.W. (May)** "You can't call it a rip off at the price".

**Your Sinclair (July)** "If you fancy a nostalgic bash (it's absolutely amazing since I've potted a good Zombie!) then rush £4.50 to D.D.S."

**Stewart Green** "Now it's only £1.99+p.p. You can't afford not to buy it!"

Cheques/Postal Orders to:  
D.D.S. Software, 49 Besumont Road, Halesowen, West Midlands, B62 9HD.

## SPECTRUM REPAIRS IN NOTTINGHAM

Fast 24 Hour Turn Round

SPECTRUM.....£17  
INTERFACE.....£17  
MICRODRIVE.....£17  
KEYBOARD.....£12

All prices inclusive of Parts, VAT & Insured Return Postage

Please send cheque or P.O. with faulty unit to:

**SPECTRUM HOSPITAL**  
CENTRALISED SERVICES LTD, PICCADILLY,  
BULWELL, NOTTINGHAM, NG6 9FN  
TEL: 0602 751153

# FRONT PAGE

This advertisement was prepared with FRONT PAGE

FRONT PAGE... is supplied as two cartridges and is user-orientated. It is complete, ready to use. Now it is possible to try desktop publishing for yourself for only **£22-50!**

DESK-TOP PUBLISHING FOR THE SINCLAIR QL

HERE IS A SUMMARY OF THE FACILITIES:

886000 pixel drawing area  
Supports all QL text sizes.  
Alternative font.  
Very simple text entry.  
User-defined graphics on 8x8 square.  
Freehand graphics.  
Cut and paste.  
Load and save full and part screens.  
Up to 98 lines and 133 columns.  
Load your own screens.  
Supports Floppies, harddisks, etc.

Of course, once you have created your masterpiece, you will want to print it. FRONT PAGE has a built-in routine to print. It allows Epsoms and Epson-compatibles to do a full A4 page. And you can customise it for your own system, as well!

Yes, the QL can now do desktop publishing, and can do it economically!

FRONT PAGE allows you to do something USEFUL with your QL. Design your own artwork, produce your Company newsletter, make up leaflets quickly.

AND DO IT ECONOMICALLY!

FRONT PAGE is:

EFFICIENTLY MENU-DRIVEN  
EASILY TO USE  
AND...

"An innovative design package with pagemaker potential. Shows small companies can still make magic." — John Gilbert, Sinclair User, Nov 86 (5 star review)

REMEMBER WHERE YOU READ IT FIRST—ON FRONT PAGE!

When replying, please mention Sinclair User

GRP SOFTWARE, 17 ST. JOHN'S TCE, LONDON, E7 6BX; 01-552-5452

P&P INCLUDED FOR UK AND EUROPE. ADD £1-99 FOR OUTSIDE EUROPE

**FREE MEMBERSHIP** Spectrum Software Hire, latest titles originals only. Send a SAE for your membership kit to: Spectrohire, Spectrum Software Club, 27 Colville Terrace, Nottingham NG1 4HL.

**QUILL USERS; THE FIX** adds five Actions PARSE, WAIT, ADD,SUB, PERFORM. £4.50 miniFIX; implementing PARSE & WAIT, £3.00 illustrator & Patch compatible, each with example adventure. Kelsoft (SU), 28 Queen Street, Stamford, Lincolnshire PE9 1QS.

**GAC USERS!** and other adventure writers, adventure contract provides advice on plotting, writing, marketing, free evaluation, interaction with other users. Sample magazine £1. Pat Winstanley, 13 Hollington Way, Wigan, WN3 6LS.

**LOOK! No more waiting 28 days for delivery. Immediate posting of goods in stock.**

Paperboy	6.50
Trivial Pursuit	11.95
Dragons Lair	6.50
Knightmare Rally	6.50
Dan Dare	8.25
Strike Force Harrier	8.25
Dracula	8.25
Sacred Armour of Antrud	7.25
All £1.99 Mastertronic games	1.75
All £2.99 Mastertronic games	2.50
Blank C15 Datasheet	30p
Spectrum (cheetah)	27.95
Joystick Interface (cheetah)	7.95
125 + joystick (cheetah)	5.75
Mach 1 joystick (cheetah)	12.95

Free £1.99 Mastertronic games with every 3 games ordered. Cheques/P.O. payable to G D COMPUTER TAPES, PO Box 106, Gloucester, GL3 4LL. Tel: (0452) 864769

Send SAE for full catalogue. All micro covered.

## SPECTRUM SOFTWARE

Each of below Microdrive Cartridges £9.75  
Microdrive Management & Recovery Package  
Indispensable, Versatile, Easy to Use — SU Review Oct '86  
Copy any type of files or cartridges even on one drive  
Sensible CAT, analyze problems, recover corrupt files.  
**FREE TEXT DATABASE & INFORMATION SYSTEMS**  
Easy to use, multi-purpose, address book, diary, letters, lists, tables. Random access, input, edit, search, print.  
**MACHINE CODE SYSTEM** (Also on tape £7.95) Assembler, Disc Assembler, test, debug trace features.  
On line machine code learning, teach yourself booklet.

Roybot SU3, 45 HULLBRIDGE ROAD  
RAYLEIGH, ESSEX SS6 9NL  
Write or tel: 0268 771663 for leaflets

**DO YOU OWN A HOME MICRO?** Do you want something more than the usual boring game? This is most certainly for you. Don't just play at life, become part of it by starting your own **HOME BASED BUSINESS**. Full or part-time. For **FREE** details S.A.E. to: Mr G McGovern SU2, 97 Pitton Place, King and Queen Street, Walworth, London SE17 1DR.

## 48k SPECTRUM Fed up with ordinary fruit machine games?

★ **NOW** ★  
A fruit machine simulation with the most up-to-date features, sound and graphics

## FRUIT 2010

★ For fruit machine experts to fun players  
★ The most advanced and realistic fruit machine simulation

**FEATURES:** Real reels — Gold Rush — Roulette-style-gamble — £100 jackpot — holds — easy keys — Nudges — HIGH-speed Spinning Reels — Save Down — Large Graphics — Mystery Box — USES ALL 48K — 12 different fruits — super sound — Cash Run — MULTIPLE ODDS — multi-colour — MAX. NUDGES — Number board

PLUS LOTS MORE

Please send **£6.95** which includes P&P  
Cheques or P.O. to **ROSSWARE SU1**  
646 London Road, Westcliff, Essex SS0 9HW  
FOR FAST DELIVERY  
Software from **ROSSWARE**

## SPECTRUM SOFTWARE HIRE

### FREE MEMBERSHIP

A wide range of games and utilities.  
Send SAE for Hire Details to:

**SSH (SU);**  
21 Chaceley Way, Wilford  
Nottingham NG11 7EG

**GODS!** This is ultimate war, the war of the Gods. A new exciting PBM game in which you're a God. £5.00 for starter part or SAE for detail. Elite Games, Ave. Henri Houssaye 16,140 Waterloo, Belgium. Tel: 384-23-63

**TURBOBAUD** (48K Spectrum) turns your programs into reliable turbo loaders, handles basic/mcode/commercial. Halves loading times. Protects and professionalises. Easy to use. Prompt despatch. £4.95. P. Stanley, 81 Jutsuns Lane, Romford, Essex.

**TV AERIAL/COMPUTER COMBINERS.** Switches automatically between computer/TV aerial without need to constantly remove plugs 1.99 10 metre aerial extension leads 3.99 Cheques/P.O.'s to N. Greenall 21 Western Circle, Burnage, Manchester M19 1HE.

**SATAN'S SERVANTS** Graphic adventure with multiple word input. Rave review 'Gazette' 48K Spectrum. Pit your wits against this devilish program £8.50 including P&P Write Taylorsoft P.O. Box 19, Redcar Cleveland TS10 2YS.

**LEARN TRANSISTOR CIRCUIT ELECTRONICS** Three massive programs linked on cassette for Spectrum 48k. Send £9.50 for ANALOGUE ELECTRONICS Groups 1-2-3. Y.T. Services Ltd., 54 Grand Avenue, Lancing W.Sussex BN15 9PZ.

## ADVERTISEMENT INDEX

Amstrad.....	IFC,3	Mancomp.....	123
Applied Technology.....	30	Micro-Control Systems.....	11
Alligata.....	60	MC Lothlorien.....	17
Alpha Plus.....	62	Micronet.....	93
Bargain Software.....	21	Microsphere.....	69
Barry Paul.....	18	Mikro Gen.....	75
Bits & Bytes.....	30	Megasave.....	62
Computer Cupboard.....	11	Miles Gordan Technology.....	6
Creative Sparks.....	70	National Software Library.....	60
Cut Price Software.....	9	Ocean.....	14,35,58,78,87,95,98
Dataskip.....	111	Penguin Books.....	17
Datel.....	43	Ram Electronics.....	103
Durrell.....	56,57	Romantic Robot.....	53
E & J Software.....	62	Shekhana.....	60
Faculty Enterprises.....	16	Selec.....	60
Forbidden Planet.....	111	Tasman.....	82,83
Gargoyle.....	38	Thetford Micro.....	30
Gremlin.....	36,37	Transform.....	110,62
Hisoft.....	70	TK Computer Ware.....	9
Incentive Software.....	11,43,9	US Gold.....	64,65,96,97
Imagine.....	46,76,77,OBC,88	Videovault.....	125,53
	107,102	Virgin.....	26
IT Western.....	30,88,107,102	Vivapost.....	122
Logic Sales.....	42	WAVE.....	9
Match.....	20	ZX Microfair.....	34
Macsen.....	IBC		



Have you noticed how many people talk about their machines by beginning "I'm the proud owner of a humble Spectrum"?

This led *Gremlin* to ponder, if one could be proud of a humble Spectrum what adjectives might be most suitable for other computers. Here are a few suggestions:

- "I am the Filofax-owning owner of an arrogant Amiga"
- "I am the serious owner of a very dull BBC B"
- "I am the wealthy but uninformed owner of a new BBC Master Compact"
- "I am the bewildered owner of a declining 6128"
- "I am the easily fooled owner of a brand new Commodore 64C"
- "Hello, I've got an Oric, is there anybody out there?"

*Gremlin* invites readers to send in their own ideas which will be either printed or ignored.



Behold Francis Lee, aka Lieutenant Witherspoon to Beyond's *Star Trek* (see *Gremlin* November)

Francis left Beyond and momentarily disappeared only to reemerge like an express as Starlight.

Starlight, it seems, is a new software house producing 'quality software on both 8- and 16-bit machines'. It seems to be living inside Ariolasoft and indeed Ariolasoft will be licencing Starlight products.

Some people regard Ariolasoft as a company 'most likely to' (most likely to what? You ask? Only lawyers prevent *Gremlin* from explaining) and Francis is, um, a surprising person to join up with.

One thing is certain though, Francis has the ability to make foot in mouth statements on a par with dear old Ronnie himself. He says "I am confident that with the addition of Starlight and other forthcoming developments, Ariolasoft will soon become a market leader across Europe." *Gremlin* though Ariolasoft, via it's huge German parent, was a European market leader already.

If it is not, how is Francis' new software house going to make all the difference? I think we should be told.

"Having saved Beyond Ariolasoft need me"



"Well the gun looks OK but I'm afraid your moustache is completely ridiculous." (Fergus McNeill and Jason Somerville do silly things for *Murder Off Miami*)

# GREMLIN'S

Time for a fresh look at the old computerlingo speak. *Gremlin* computes.

The ol' data base of reference tokens needs to be up-dated. Here are the latest translations: **Megagame:** software house is charging more than £9.95 for it

**Budget title:** 'There's no way we can get away with a full price tag on this one'

**Saucy:** Contains a breast, probably female, constructed from five pixels

**15 rated:** Clement Chambers'



## GREMLINS FOR 1987

- Amstrad will produce a Spectrum with disc drives that will not be compatible with any existing disc software.
- Sinclair Research will finally produce Pandora and it will not be compatible with anything including the United Kingdom mains system (Sinclair will offer to rewire your house to make it compatible with Pandora for £49.95 plus VAT)
- *Star Trek* will be released three months later than the latest date anyone imagined it would be released.
- The best Spectrum games of 1987 will be better than the best games of 1986. The worst games will be at least as bad.
- The world will not end

### THE GREMLIN GUIDE TO HOW NOT TO CONSTRUCT A PROMOTIONAL PICTURE: Part 1 Peter Shilton's Handball Maradonna

Name of game: Peter Shilton's Football. Whatever happened to the Handball Maradonna bit

These curious cropped pictures take journalist's gaze away from the central action Mysterious indoor TV aerial. Does Peter really watch TV in this position?

Peter has an old style Spectrum - unconvincing Limp joystick grip suggests Peter is not excited



Screen could not be more boring - no action whatsoever, suggests game was not ready when picture was taken. Also implies that Peter Shilton has been practicing

MFI style computer desk - not associated with game credibility

Fixed uncomprehending grin suggests 'I have been told to smile at the camera and hope I can get away soon'. Peter would not be very successful should he choose to play the game in this position

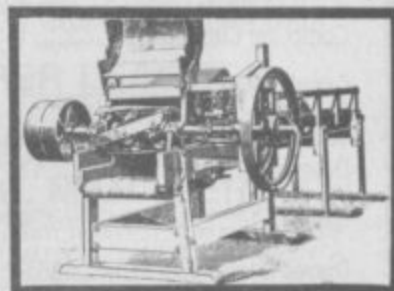

Pandora for £49.95 plus VAT





# 'S JARGON GUIDE

ridiculous publicity stunt (lots of red pixels)

**Classic-style adventure:** Lots of pixies but no graphics

**Hilarious adventure:** Only a few pixies, written with the Quill, not funny with, poor graphics

**Monster memory:**

128K Action-packed

**program:** Firing at things

**Ultimate arcade game:** Firing at things and dodging things

**Disappointing response:** Even the journalists sent their

review copies back

**Original game:** Looks weird but isn't fun to play

**Whacky:** Totally terrible in every way without any redeeming features whatsoever

**Licencing deal:** Licence to print money or - as insult - a very, very bad game

**Multi-channel sound:**

Da,a,a,a,a,a,de,e,e,e,e,e,do,o,o,o,o, etc

**Sampled speech:**

MisarrrrwwllllsLanchhheeeed

**Real-time:** No Pause button if the phone rings



"Don't push me, I'm not that far away from the edge."

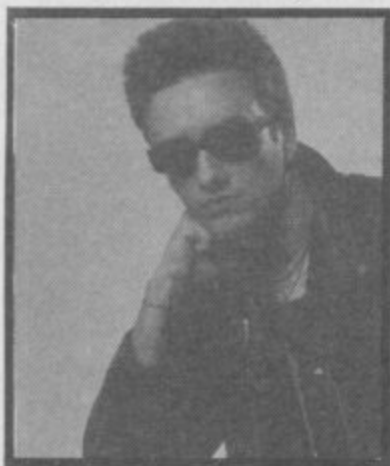

Some things become *Gremlin* material, other things have *Gremlin* status thrust upon them.

Still others cry out to be included.

This promo pic from CSD is such a one. Never has there been a more posy photograph of a programmer (unless of course you know different). How on earth was Mark Rivers persuaded to look like a complete prat?

Someone in CSD obviously decided that Mark was marketable material, this was almost certainly because he is one of the very few programmers that has what can only be described as tall hair. Not only does he have tall hair but he has dark sunglasses.

Clearly he's a street urchin living for the moment, drivin' down the fast lane (note the shark's tooth earrings showing that he's a dangerous character). *Gremlin* wouldn't ordinarily mock someone who could go unnoticed in, say, the pages of *Sounds* but Mark has adopted the most astonishingly ridiculous 'I am mean' pose. Of Mark's games and character *Gremlin* can make no comment except that they are said to be 'action packed and super sophisticated' and will 'stun the world'.

Personally *Gremlin* thinks Mark would be better off trying to stun (possibly permanently) the people who write press releases about him



## CAPTION COMP No 3

Good grief. Last month the caption competition gave you only about three and a half days to get your ideas in and yet they flooded in.

Some of them were even funny. Feargal seemed to inspire you to new heights.

Ideas were a mixture of insults directed towards the mighty BBC computer in the background of the picture and jokes based around titles of Fergies (some mistake?) greatest hits.

An example of the latter being 'That was Dr Barnard asking if I'd found a good heart' from S McCarthy of Newark (How are you Steve?).

Alas most of the insults to the BBC computer were far too rude to print. *Gremlin* was quite taken with 'I think I've just sat on the joystick' from Steve Spiers of Oxford just because of the fact that Feargal does actually look like this might be his problem.

George Ward's 'Hello do you know me?' was liked as an access joke as we 'I knew I should have put on a tie this morning' from D Roberts of London.

However the winner, for economy of words, and general sarcasm comes from Chris Alauoine (if this is wrong you only have your writing to blame, Chris) of Rockford in Essex who penned "OK then guys, where's the celebrity?". Chris gets the usual cash reward.



And finally. Another year has passed, many hands make light work and a stitch in time saves nine.

You know, sometimes we all complain a little don't we, we have our little ups and downs, our little setbacks and our victories, but now, at the end of the year, it's time to forget life's little difficulties and give thanks.

At **SU** there are so many things for us to give thanks for. Some good software to review, Jeffery Archer's resignation, *Faster Than Light* for easily the best sweat shirts we've ever seen.

Thanks obviously to all of you for all the praise (and blame) you've hurled at us.

But most of all we'd like to thank all the guys at *Crash!* for the tremendous support and coverage they've given us in their magazine recently and for all their incredible efforts in helping us to increase our readership.



Thanks again guys

This month's picture shows Anita Sinclair, Princess of power at Magnetic Scrolls selling/bribing/showing Sir Clive a copy of the Pawn. So here's your caption task this month: Who is saying or thinking what? (Note: juvenile sexist comments might be sniggered over in the office but won't be printed and won't win and that's that. £20 for the winner.)



Send your offering to *Gremlin* Caption Competition No 3, Sinclair User, Priory Court, 30/32 Farringdon Lane, London EC1R 3AU. Entries must reach us by 7th of January, which an incredibly long time for you to come up with the goods.

Name.....  
Address.....  
Caption (max 12 words).....

# Any more realistic and you'd need insurance to ride it.

There are two guys in front. One coming up from behind. And another just off your elbow. The screams of the bikes are deafening.

The wind is pulling your face off your head. Your adrenaline is pumping like Hoover Dam.

You kick your bike to the right. He's

bumped. He's flying. You push on.

Take your eyes off the road for a millisecond, and you could end up a *part* of the road.

It's all a blur. No time to think. You've just gotta pump it. The next turn's the steep one. Bank, bank! The curve's wide open, but the screeching wheels of the

bike in front are kicking gravel right in your...your...

You hear a phone. A phone? Hey, wait a minute. This isn't a bike. It's a chair. It all comes back now. Yes. You're home. The pizza's here. The computer's on. Looks like it's going to be another quiet night after all.



On Super Cycle™ If it were any more realistic, you'd need insurance to ride it.

Commodore 64	Disk	£14.95
	Cassette	£9.95
Spectrum 48K	Cassette	£7.95
Amstrad	Disk	£14.95
	Cassette	£9.95

## SUPER CYCLE

Manufactured in the UK under license from Epyx by  
U.S. Gold Limited,  
Unit 2/3, Holford Way, Holford, Birmingham, B6 7AX.  
Telephone: 021-356 3388

Epyx is a registered trademark No. 006270  
Screen shot from Commodore 64/128 version of game.



**EPYX**™  
COMPUTER SOFTWARE



**BULLSEYE**  
Millions enjoy this popular TV darts game, and now you can join Bully on the oche where you aim to win and throw to answer! A good arrow and you can pick your favourite topic ranging from Food to Pot Luck – a correct answer, and you're on your way! Do you want to gamble! £8.95

**BLOCKBUSTERS**  
Sixty million people every week watch Blockbusters, Britain's most popular TV quiz game! Now, thanks to Macsen software, you can actually be a contestant, recreating the excitement of the TV studio in your own home. Our Question-master follow-up give you 500 more questions, plus the chance to insert your own – be your own Bob! £7.95

**GOLD RUN**  
Can you beat a path through the hexagons to go for gold? The tension of this sister-game to Blockbusters is terrific, as the contestant struggles to complete his path against the clock. Adjust your own answering time to push yourself harder! £9.95

Macsen Software presents television's most popular programmes for your computer.

With our productions you can take part in your favourite programme and turn your living room into the television world of stars and sagas.



**BLOCKBUSTERS & GOLD RUN**  
Now available for C16

Unit 1, Dafen Industrial Park, Llanelli, Dyfed, SA14 9UU. Tel: 0554 776684

# THE WINNING HAND THIS CHRISTMAS.

Blockbusters, Bullseye, Gold Run, Treasure Hunt and EastEnders available on: Commodore 64, Spectrum 48K, BBC Model B, Electron, Amstrad. Countdown on Commodore 64, Spectrum 48K, BBC Model B, Amstrad.

All games available from leading computer departments and computer stores.



AMSTRAD 18.95  
ZX SPECTRUM 17.95  
COMMODORE 64 18.95

# LEGEND OF KAGE



...the name  
of the game

Imagine Software (1984) Limited  
6 Central Street • Manchester M2 5NS •  
Tel: 061 834 3939 • Telex: 669977



\*Licensed from © Taito Corp., 1986. Programmed for (Amstrad, Spectrum, Commodore)